

MAJESTIC

Builder Direct Vent Models:

36CDVXRRN (Rear Vent)

36CDVXTRN (Top Vent)

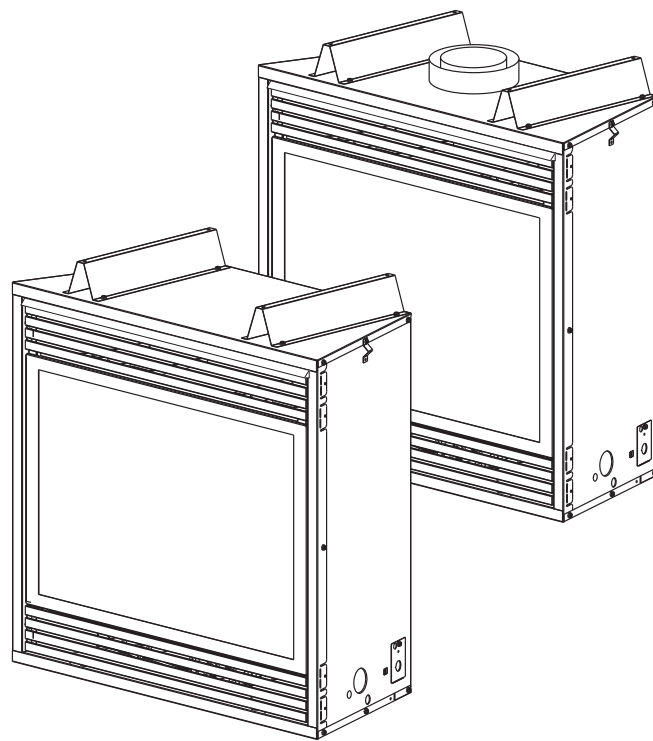

Installation Instructions and Homeowner's Manual



INSTALLER/CONSUMER SAFETY INFORMATION

PLEASE READ THIS MANUAL
BEFORE INSTALLING AND
USING APPLIANCE

WARNING!
IF THE INFORMATION IN THIS
MANUAL IS NOT FOLLOWED
EXACTLY, A FIRE OR EXPLO-
SION MAY RESULT CAUSING
PROPERTY DAMAGE, PER-
SONAL INJURY OR LOSS OF
LIFE.

FOR YOUR SAFETY
Installation and service must
be performed by a qualified
installer, service agency or
the gas supplier.

WHAT TO DO IF YOU SMELL GAS:

- Do not try to light any appliance.
- Do not touch any electric switch;
do not use any phone in your
building.
- Immediately call your gas
supplier from your neighbor's
phone. Follow the gas suppliers
instructions.
- If you cannot reach your gas
supplier call the fire department.

DO NOT STORE OR USE
GASOLINE OR OTHER
FLAMMABLE VAPORS AND
LIQUIDS IN THE VICINITY OF
THIS OR ANY OTHER
APPLIANCE.

INSTALLER: Leave this manual with the appliance.
CONSUMER: Retain this manual for future reference.

Table of Contents

PLEASE READ THE INSTALLATION & OPERATING INSTRUCTIONS BEFORE USING APPLIANCE.

Thank you and congratulations on your purchase of a MHSC fireplace.

IMPORTANT: Read all instructions and warnings carefully before starting installation.

Failure to follow these instructions fully may result in a possible fire hazard and will void the warranty.

Installation & Operating Instructions

General Information, Warnings, Cautions.....	3
Requirements for the Commonwealth of Massachusetts	4
Fireplace Dimensions	5
Locating Your Fireplace	7
Clearance to Combustibles	7
Mantels	7
Hearth	8
Framing and Finishing	8
Hood Installation	8
Final Finishing	8
Gas Specifications	9
Gas Inlet and Manifold Pressures	9
High Elevations.....	9
Gas Line Installation	9
Remote ON/OFF Switch.....	9
120V Electrical Hook Up.....	10

General Venting Information

General Venting.....	10
General Venting Information-Termination Location	11
General Information Assembling Vent Pipes	12
36CDVXR Venting - How to Use the Vent Graph	13
Rear Wall Venting Applications & Installation (Exterior outside wall 7" - 20" from rear of unit).....	13
Rear Wall Vent Installation - Flex Vent Pipe	15
Rear Wall Vent Application (Exterior outside wall 13" - 20" from rear of unit).....	16
Rear Wall Vent Application (Exterior outside wall 20" - 32" from rear of unit).....	16
Vertical Sidewall Applications & Installation.....	17
Below Grade Installation.....	19
Vertical Through-the-Roof Applications & Installation.....	20
36CDVXT Vertical Venting - How to Use the Vent Graph.....	22
36CDVXT Top Vent Baffle	22
Vertical Sidewall Applications & Installation.....	23
Below Grade Installation.....	25
Vertical Through-the-Roof Applications & Installation.....	26
Venting Components	28

Operating Instructions

Glass Information	29
Louvre Removal	29
Window Frame Assembly Removal.....	29
Glass Cleaning	29
Logs	30
Ember Material and Lava Rock Placement	30
Flame & Temperature Adjustment	30
Flame Characteristics	30
Lighting and Operating Instructions.....	31
Troubleshooting	33
Fuel Conversion Instructions	34

Maintenance

Cleaning the Standing Pilot Control System.....	36
---	----

Replacement Parts

.....	37
-------	----

Optional Accessories

.....	39
-------	----

Warranty

.....	43
-------	----

Energide

.....	44
-------	----

Installation & Operating Instructions

This gas appliance should be installed by a qualified installer, preferably NFI or WETT (Canada) certified, in accordance with local building codes and with current CSA-B149.1 Installation codes for Gas Burning Appliances and Equipment. For USA Installations follow local codes and/or the current National Fuel Gas Code. ANSI Z223.1/NFPA 54.

FOR SAFE INSTALLATION AND OPERATION PLEASE NOTE THE FOLLOWING:

1. This fireplace gives off high temperatures and should be located out of high traffic areas and away from furniture and draperies.
2. Children and adults should be alerted to the hazards of high surface temperatures of this fireplace and should stay away to avoid burns or ignition of clothing.
3. **CAUTION: Due to high glass surface temperature children should be carefully supervised when in the same room as fireplace.**

WARNING



HOT GLASS WILL CAUSE BURNS.

DO NOT TOUCH GLASS UNTIL COOLED.

NEVER ALLOW CHILDREN TO TOUCH GLASS.

4. Under no circumstances should this fireplace be modified. Parts removed for servicing should be replaced prior to operating this fireplace again.
5. Installation and any repairs to this fireplace must be performed by a qualified installer, service agency or gas supplier. A professional service person should be contacted to inspect this fireplace annually. Make it a practice to have all of your gas fireplaces checked annually. More frequent cleaning may be required due to excess lint and dust from carpeting, bedding material, etc.
6. Control compartments, burners and air passages in this fireplace should be kept clean and free of dust and lint. Make sure the gas valve and pilot light are turned off before you attempt to clean this fireplace.
7. The venting system (chimney) of this fireplace should be checked at least once a year and if needed your venting system should be cleaned.
8. Keep the area around your fireplace clear of combustible materials, gasoline and other flammable vapor and liquids. This fireplace should not be used as a drying rack for clothing, nor should Christmas stockings or decorations be hung on or around the fireplace.
9. Under no circumstances should any solid fuels (wood, coal, paper or cardboard etc.) be used in this fireplace.
10. The flow of combustion and ventilation air must not be obstructed in any way.
11. When fireplace is installed directly on carpeting, vinyl tile or any combustible material other than wood, the fireplace must be installed on a metal or wood panel extending the full width and depth of the fireplace.
12. This fireplace requires adequate ventilation and combustion air to operate properly.

13. This fireplace must not be connected to a chimney flue serving a separate solid fuel burning fireplace.
14. When the fireplace is not in use it is recommended that the gas valve be left in the **OFF** position.
15. These units have been approved for bedroom use.

36CDVXR / 36CDVXT

Certified To

ANSI Z21.88b-2008 / CSA 2.33b-2008

Vented Gas Fireplace Heaters

WARNING: Check with your electronics manufacturer before installing a television or other electronic device above this fireplace.

This appliance may be installed in an aftermarket permanently located, manufactured home or mobile home, where not prohibited by local codes.

This appliance is only for use with the type of gas indicated on the rating plate. This appliance is not convertible for use with other gases, unless a certified kit is used.

The CDVXR has been approved for mobile home installations.

IMPORTANT:

PLEASE REVIEW THE FOLLOWING CAREFULLY

Remove any plastic from trim parts before turning the fireplace ON.

It is normal for fireplaces fabricated of steel to give off some expansion and/or contraction noises during the start up or cool down cycle. Similar noises are found with your furnace heat exchanger or car engine.

It is not unusual for your gas fireplace to give off some odor the first time it is burned. This is due to the curing of the paint and any undetected oil from the manufacturing process.

Please ensure that your room is well ventilated - open all windows.

It is recommended that you burn your fireplace for at least ten (10) hours the first time you use it. If the optional fan kit has been installed, place the fan switch in the "OFF" position during this time.

Proposition 65 Warning: Fuels used in gas, wood-burning or oil fired appliances, and the products of combustion of such fuels, contain chemicals known to the State of California to cause cancer, birth defects and other reproductive harm.

California Health & Safety Code Sec. 25249.6

Installation & Operating Instructions

Requirements for the Commonwealth of Massachusetts

All gas fitting and installation of this heater shall only be done by a licensed gas fitter or licensed plumber.

For all side wall horizontally vented gas fueled equipment installed in every dwelling, building or structure used in whole or in part for residential purposes, including those owned or operated by the Commonwealth and where the side wall exhaust vent termination is less than seven (7) feet above finished grade in the area of the venting, including but not limited to decks and porches, the following requirements shall be satisfied:

Installation of Carbon Monoxide Detectors

At the time of installation of the side wall horizontal vented gas fueled equipment, the installing plumber or gas fitter shall observe that a hard wired carbon monoxide detector with an alarm is installed on each additional level of the dwelling, building or structure served by the side wall horizontal vented gas fueled equipment. It shall be the responsibility of the property owner to secure the services of qualified licensed professionals for the installation of hard wired carbon monoxide detectors.

In the event that the side wall horizontally vented gas fueled equipment is installed in a crawl space or an attic, the hard wired carbon monoxide detector with alarm and battery back-up may be installed on the next adjacent floor level.

In the event that the requirements of this subdivision can not be met at the time of completion of installation, the owner shall have a period of thirty (30) days to comply with the above requirements; provided, however, that during said thirty (30) day period, a battery operated carbon monoxide detector with an alarm shall be installed.

Approved Carbon Monoxide Detectors

Each carbon monoxide detector as required in accordance with the above provisions shall comply with NFPA 720 and ANSI/UL 2034 listed and IAS certified.

Signage

A metal or plastic identification plate shall be permanently mounted to the exterior of the building at a minimum height of eight (8) feet above grade directly in line with the exhaust vent terminal for the horizontally vented gas fueled heating appliance or equipment. The sign shall read, in print size no less than one-half (1/2) inch in size, "**GAS VENT DIRECTLY BELOW, KEEP CLEAR OF ALL OBSTRUCTIONS**".

Inspection

The state or local gas inspector of the side wall horizontally vented gas fueled equipment shall not approve the installation unless, upon inspection, the inspector observes carbon monoxide detectors and signage installed in accordance with the provisions of 248 CMR 5.08(2)(a)1 through 4.

Exemptions

The following equipment is exempt from 248 CMR 5.08(2)(a)1 through 4:

- The equipment listed in Chapter 10 entitled "Equipment Not Required To Be Vented" in the most current edition of NFPA 54 as adopted by the Board; and
- Product Approved side wall horizontally vented gas fueled equipment installed in a room or structure separate from the dwelling, building or structure used in whole or in part for residential purposes.

MANUFACTURER REQUIREMENTS

Gas Equipment Venting System Provided

When the manufacturer of Product Approved side wall horizontally vented gas equipment provides a venting system design or venting system components with the equipment, the instructions provided by the manufacturer for installation of the equipment and the venting system shall include:

- Detailed instructions for the installation of the venting system design or the venting system components; and
- A complete parts list for the venting system design or venting system.

Gas Equipment Venting System NOT Provided

When the manufacturer of a Product Approved side wall horizontally vented gas fueled equipment does not provide the parts for venting the flue gases, but identifies "special venting systems", the following requirements shall be satisfied by the manufacturer:

- The referenced "special venting system" instructions shall be included with the appliance or equipment installation instructions; and
- The "special venting systems" shall be Product Approved by the Board, and the instructions for that system shall include a parts list and detailed installation instructions.

A copy of all installation instructions for all Product Approved side wall horizontally vented gas fueled equipment, all venting instructions, all parts lists for venting instructions, and/or all venting design instructions shall remain with the appliance or equipment at the completion of the installation.

Fireplace Dimensions - Rear Vent

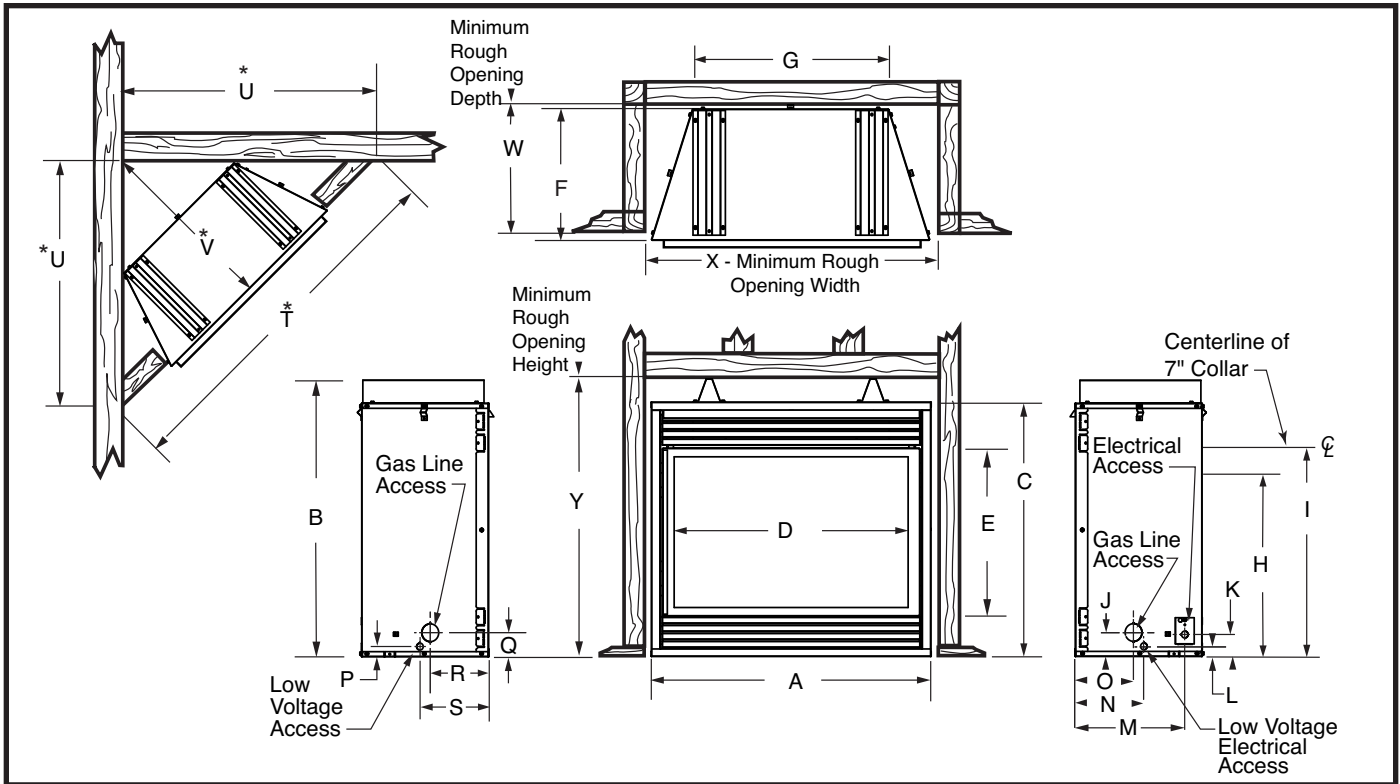

Fig. 1 Fireplace specifications and framing dimensions.

Ref.	36CDVXR			
A	35 ¹ / ₄ "	(895 mm)		
B	34 ³ / ₄ "	(883 mm)		
C	32 ¹ / ₈ "	(816 mm)		
D	33"	(838 mm)		
E	21 ¹ / ₈ "	(537 mm)		
F	16 ⁵ / ₈ "	(422 mm)		
G	25"	(635 mm)		
H	18 ¹ / ₂ "	(470 mm)		
I	22"	(559 mm)		
J	3 ¹ / ₄ "	(83 mm)		
K	2 ⁷ / ₈ "	(73 mm)		
L	1 ³ / ₈ "	(35 mm)		
M	14"	(356 mm)		
N	8 ¹ / ₂ "	(216 mm)		
O	7 ³ / ₈ "	(187 mm)		
P	1 ³ / ₈ "	(35 mm)		
Q	3 ¹ / ₄ "	(83 mm)		
R	7 ³ / ₈ "	(187 mm)		
S	8 ¹ / ₂ "	(216 mm)		
Framing Dimensions		If using Rigid 45° with Starter Pipe		
T*	68 ¹ / ₄ "	(1734 mm)	58 ³ / ₈ "	(1483 mm)
U*	48 ¹ / ₄ "	(1226 mm)	41 ³ / ₈ "	(1051 mm)
V*	34 ¹ / ₈ "	(867 mm)	29 ¹ / ₈ "	(740 mm)
W	17 ¹ / ₈ "	(435 mm)		
X	36 ¹ / ₄ "	(921 mm)		
Y	35"	(889 mm)		

* Must be adhered to if using 7TCD45KT Flex Vent Kit

Fireplace Dimensions - Top Vent

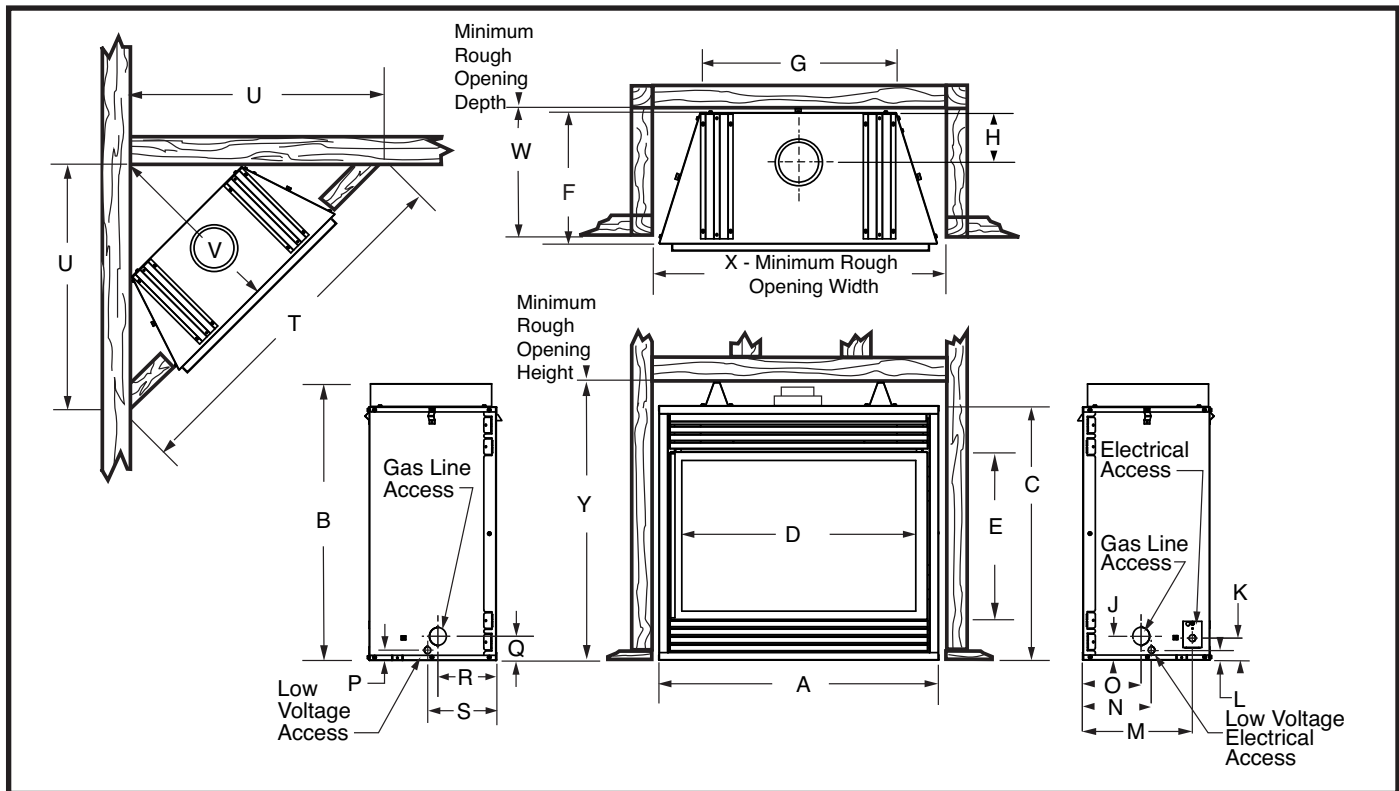

Fig. 2 Fireplace specifications and framing dimensions.

Ref.	36CDVXT	
A	35 ¹ / ₄ "	(895 mm)
B	34 ³ / ₄ "	(883 mm)
C	32 ¹ / ₈ "	(816 mm)
D	33"	(838 mm)
E	21 ¹ / ₈ "	(537 mm)
F	16 ⁵ / ₈ "	(422 mm)
G	25"	(635 mm)
H	8"	(203 mm)
J	3 ¹ / ₄ "	(83 mm)
K	2 ⁷ / ₈ "	(73 mm)
L	1 ³ / ₈ "	(35 mm)
M	14"	(356 mm)
N	8 ¹ / ₂ "	(216 mm)
O	7 ³ / ₈ "	(187 mm)
P	1 ³ / ₈ "	(35 mm)
Q	3 ¹ / ₄ "	(83 mm)
R	7 ³ / ₈ "	(187 mm)
S	8 ¹ / ₂ "	(216 mm)
Framing Dimensions		
T	58 ³ / ₈ "	(1483 mm)
U	41 ³ / ₈ "	(1051 mm)
V	29 ¹ / ₈ "	(740 mm)
W	17 ¹ / ₈ "	(435 mm)
X	36 ¹ / ₄ "	(921 mm)
Y	35"	(889 mm)

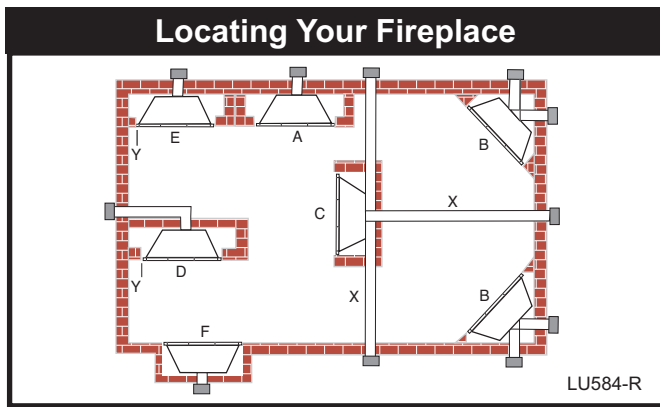

Fig. 3 Locate gas fireplace.

- A) Flat on wall B) Cross corner C) **Island
- D) Room divider E) Flat on wall corner F) Chase installation
- Y) Refer to "Clearance to Combustibles" Section

NOTE: (Fig. 3)

** Island (C) and Room Divider (D) installation is possible as long as the horizontal portion of the vent system (X) does not exceed 20' (6 m) with a minimum vertical of 4' (122 cm). See details in Venting Section.

Clearance to Combustibles

- Top of Unit to Ceiling 36" (914 mm)
- Front of Unit to Combustibles 36" (914 mm)

Appliance

- Top 0" (0 mm)
- Bottom 0" (0 mm)
- Side 0" (0 mm)
- Back 0" (0 mm)

Venting

- Concentric sections of DV Vent
 - Top, bottom & sides 1" (25 mm)
- Flex Vent 7/8" (22 mm)

NOTE: Hood must be permanently installed with three (3) sheet metal screws supplied in fireplace. (Refer to hood installation in this manual.)

Mantels

The height that a combustible mantel is fitted above the fireplace is dependent on the depth of the mantel. This also applies to the distance between the mantel leg (if fitted) and the fireplace.

For the correct mounting height and widths refer to Figs. 4a and 4b, and the following Mantel Charts.

The fitting of a bay window trim kit does not effect the distances and reference points referred to in the diagram and chart.

Noncombustible mantels and legs may be installed at any height and width around the appliance.

When using paint or lacquer to finish the mantel, such paint or lacquer must be heat resistant to prevent discoloration.

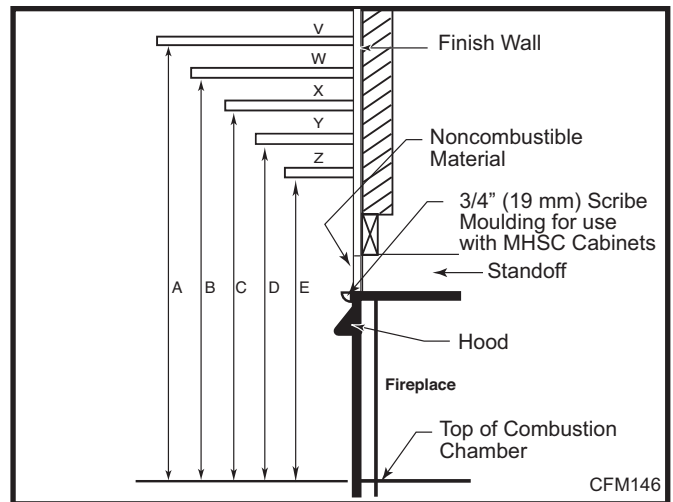

Mantel Chart			
Ref.	Mantel Shelf or Breast Plate Depth	Ref.	Mantel from Top of Combustion Chamber
V	10" (254 mm)	A	17" (432 mm)
W	8" (203 mm)	B	15" (381 mm)
X	6" (152 mm)	C	13" (330 mm)
Y	4" (101 mm)	D	11" (279 mm)
Z	2" (51 mm)	E	9" (229 mm)

Fig. 4a Combustible mantel minimum installation.

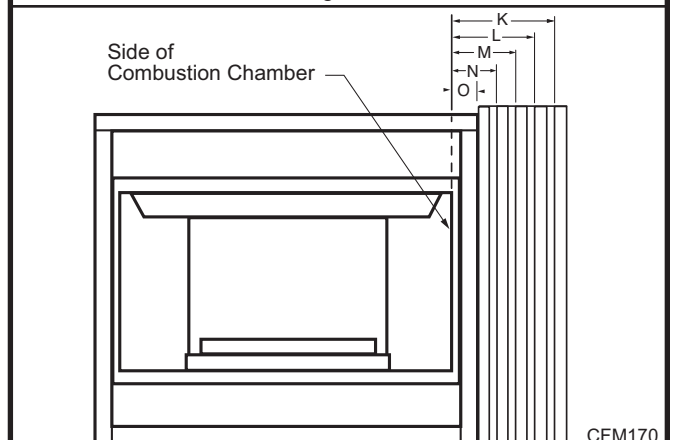
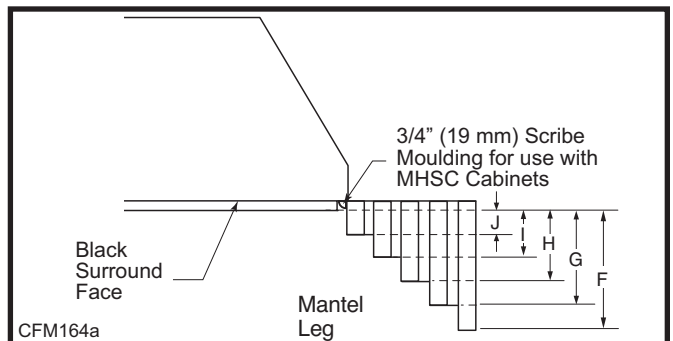

Ref.	Mantel Leg Depth	Ref.	Mantel Leg From Side of Comb. Opening
F	10" (254 mm)	K	11½" (292 mm)
G	8" (203 mm)	L	9½" (241 mm)
H	6" (152 mm)	M	7½" (191 mm)
I	4" (101 mm)	N	5½" (140 mm)
J	2" (51 mm)	O	3½" (89 mm)

Fig. 4b Combustible mantel leg minimum installation.

Hearth

A hearth is not mandatory but is recommended for aesthetic purposes. We recommend a noncombustible hearth which projects out 12" (305 mm) or more from the front of the fireplace.

Cold climate installation recommendation:



When installing this unit against a non-insulated exterior wall or chase, it is mandatory that the outer walls be insulated to conform to applicable insulation codes.

Framing and Finishing



Check fireplace to make sure it is levelled and properly positioned.

To mount the appliance:

1. Choose the location.
2. This unit comes with four (4) flanges pre-mounted on both sides of the fireplace to allow two different drywall thicknesses to be used. Flange "A" is for 1/2" drywall while flange "B" is for 5/8" drywall.
3. Bend the desired flanges out 90° on both sides of the fireplace. Slide the fireplace into the framed opening until the flanges contact the front surfaces of the framing. Level the unit and secure it firmly in place.
4. The standoffs are adjustable for different drywall thicknesses. The unit is shipped from the factory at 1/2" (13 mm). Loosen the four (4) screws securing each standoff to the top of the fireplace. Slide the standoff back. Tighten the screws. This yields a 5/8" (16 mm) thick drywall space. Removing the standoff and having the tabs on the standoff face the rear of the unit yields a 3/4" (19 mm) drywall space. (Fig. 5)

NOTE: Drywall **must** stop at standoffs and not touch top of unit.

Hood Installation

CAUTION: Hood MUST be permanently installed.

1. Remove top louvre. Carefully remove hood from inside top louvre opening.
2. Remove three (3) sheet metal screws in bottom flange of fireplace surround top.
3. Install the hood by aligning the three holes in bottom flange of fireplace surround top. (Fig. 6)
4. Secure hood to bottom flange of fireplace surround top using three screws removed in Step 2. (Fig. 6)
5. Carefully remove protectors under the relief plates on top of the firebox.
6. Replace top louvre.

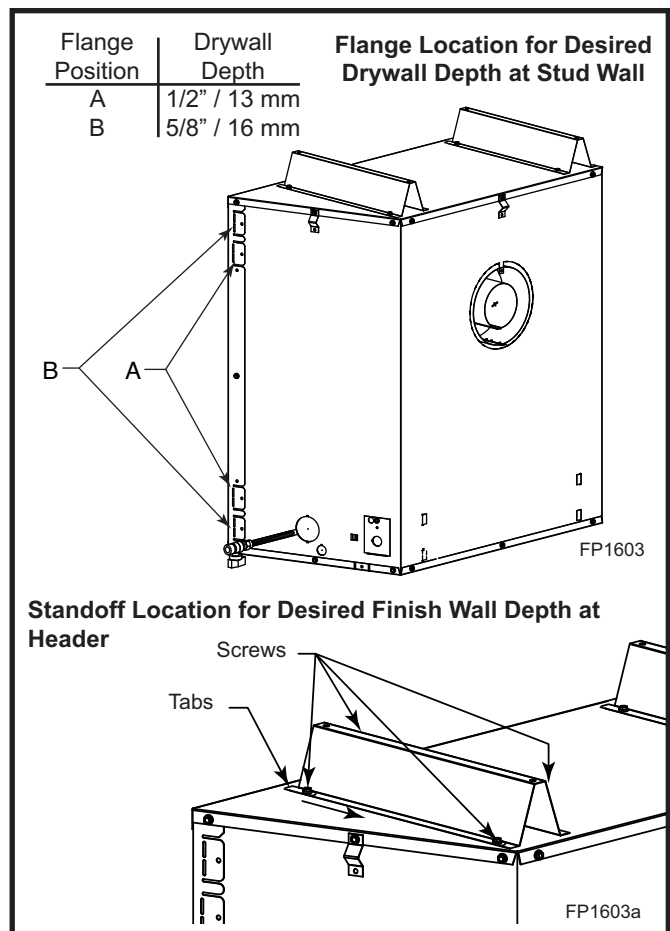

Fig. 5 Nailing flanges and standoffs.

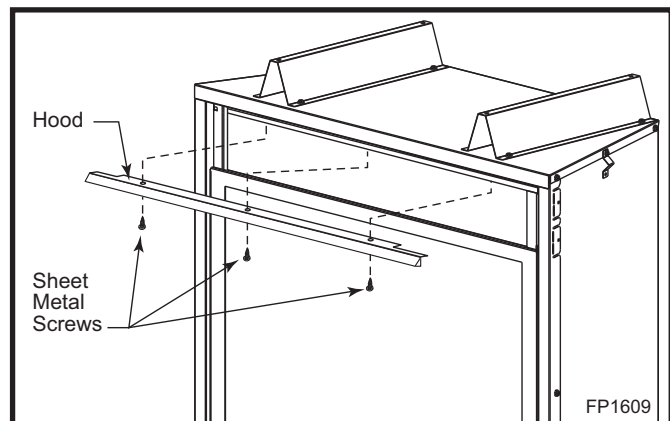

Fig. 6 Secure hood to fireplace with sheet metal screws.

Final Finishing

Noncombustible materials such as brick or tile may be extended over the edges of the face of the fireplace. **DO NOT** cover any vent or grille panels. If a Trim Kit is going to be installed on the fireplace, the brick or tile will have to be installed flush with the edges of the fireplace.

Gas Specifications				
			Max. Input	Min. Input
Model	Fuel	Gas Control	BTU/h	BTU/h
36CDVXRRN	Nat	Millivolt	21,000	14,700
36CDVXRRP*	Prop	Millivolt	21,000	15,750
36CDVXTRN	Nat	Millivolt	21,000	14,700
36CDVXTRP*	Prop	Millivolt	21,000	15,750

*Using conversion kit

Gas Inlet and Manifold Pressures		
	Natural	LP (Propane)
Inlet Minimum	5.5" w.c.	11.0" w.c.
Inlet Maximum	14.0" w.c.	14.0" w.c.
Manifold Pressure	3.5" w.c.	10.0" w.c.

High Elevations

Input ratings are shown in BTU per hour and are certified without deration for elevations up to 4,500 feet (1,370 m) above sea level.

For elevations above 4,500 feet (1,370 m) in USA, installations must be in accordance with the current ANSI Z223.1/NFPA 54 and/or local codes having jurisdiction.

In Canada, please consult provincial and/or local authorities having jurisdiction for installations at elevations above 4,500 feet (1,370 m).

Gas Line Installation

When purging the gas lines, the front window frame assembly must be removed.

The gas pipeline can be brought in through the rear of the appliance as well as the bottom. Knockouts are provided on the bottom behind the valve to allow for the gas pipe installation and testing of any gas connection. It is most convenient to bring the gas line in from the rear right side of the valve as this allows fan installation or removal without disconnecting the gas line.

The gas line connection can be made with properly tinned 3/8" copper tubing, 3/8" rigid pipe or an approved flex connector. Since some municipalities have additional local codes, it is always best to consult your local authority and the National Fuel Gas Code, ANSI Z223.1/NFPA 54 in the USA or the CSA-B149.1 installation code.

Always check for gas leaks with a mild soap and water solution. Do not use an open flame for leak testing.

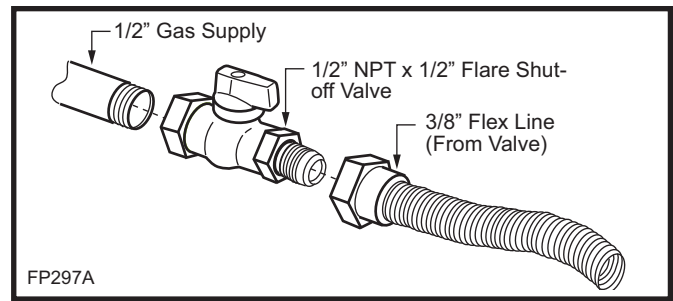

Fig. 7 Typical gas supply installation.

The gas control is equipped with a captured screw type pressure test point, therefore it is not necessary to provide a 1/8" test point up stream of the control.

When using copper or flex connector use only approved fittings. Always provide a union when using black iron pipe so the gas line can be easily disconnected for burner or fan servicing. See gas specification for pressure details and ratings.

The fireplace valve must not be subjected to any test pressures exceeding 1/2 psi. Isolate or disconnect this and any other gas appliance control from the gas line when pressure testing.

Remote ON/OFF Switch

Installation

- Carefully unwrap the remote wire that is attached to the valve. There are two 1/2" (13 mm) knockouts, one on each side of the outer casing.
- Remove the knockout desired and insert the plastic snap bushing on the remote wire in the 1/2" hole. Feed the remote wire through the outer casing.
- Attach the wire to an ON/OFF switch and install the switch into the receptacle box. (Fig. 8)

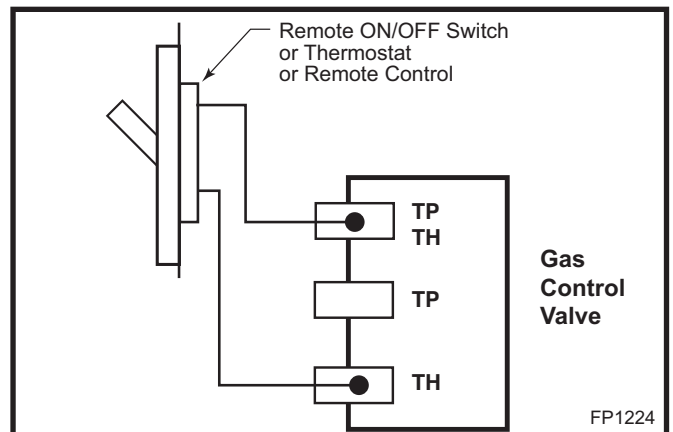

Fig. 8 Remote switch wiring diagram.

Do not wire the remote ON/OFF wall switch for the gas fireplace to the 120 volt power supply.

120V Electrical Hook Up



The fireplace, when installed, must be electrically connected and grounded in accordance with local codes or, in the absence of local codes, with the current CSA C22.1 Canadian Electrical Code.



For USA installations follow local codes and the national electrical code ANSI/NFPA No. 70.



It is strongly suggested that wiring of the Electrical Junction Box be carried out by a licensed electrician.



Ensure that the power to the supply line has been disconnected before commencing this procedure.

The electrical junction box has been fitted standard on this model to allow for the easy connection of an optional fan kit.

To connect the electric box to the house electrical supply follow the steps below.

1. Unscrew the retaining screw holding the electric cover to the outside of the unit. (Fig. 9)
2. Remove the knockout from the electric cover plate.
3. Insert the wire connector through the hole in the electric cover plate and secure.

4. Insert the house wire through the connector on the cover plate.
5. Secure the wires from the receptacle to the incoming line.
6. The receptacle has four wires connected to it. The receptacle is set up for a split system. The top plug of the receptacle is wired separately from the bottom one.
7. Green is ground. White is neutral, Black and red are line voltage to each plug on the receptacle.

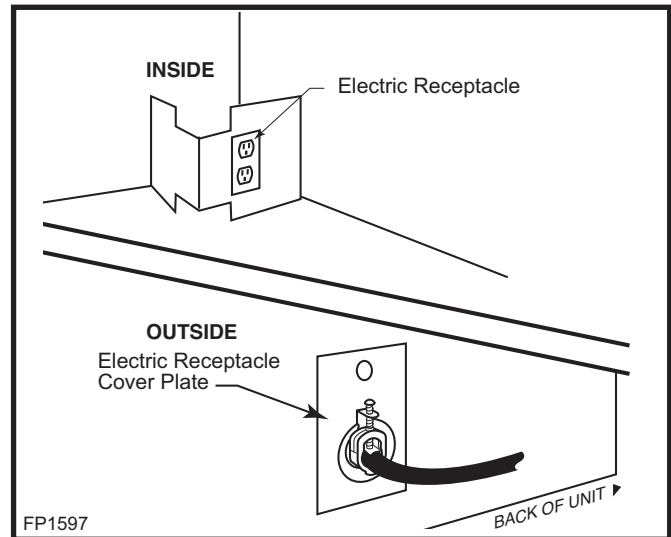

Fig. 9 Electric receptacle.

General Venting

Your fireplace is approved to be vented either through the side wall, or vertically through the roof.

- Only MHSC venting components specifically approved and labelled for this fireplace may be used.
- Vent terminations shall not be recessed into a wall or siding.
- Horizontal venting which incorporates the twist lock pipe must be installed on a level plane without an inclining or declining slope.
- Horizontal venting which incorporates the use of flex venting shall have an inclining slope from the unit of 1" (25 mm) per 24" (610 mm).

There must not be any obstruction such as bushes,

garden sheds, fences, decks or utility buildings within 24" (610mm) from the front of the termination hood.

Do not locate termination hood where excessive snow or ice build up may occur. Be sure to check vent termination area after snow falls, and clear to prevent accidental blockage of venting system. When using snow blowers, make sure snow is not directed towards vent termination area.

Location of Vent Termination

It is imperative the vent termination be located observing the minimum clearances as shown on the next page.

*Check with local codes or in absence of same with CSAB149.1 Installation Codes (1991) for Canada or follow the current National Fuel Gas Code, ANSI Z223.1/NFPA 54 for installations in the USA.

General Venting Information - Termination Location

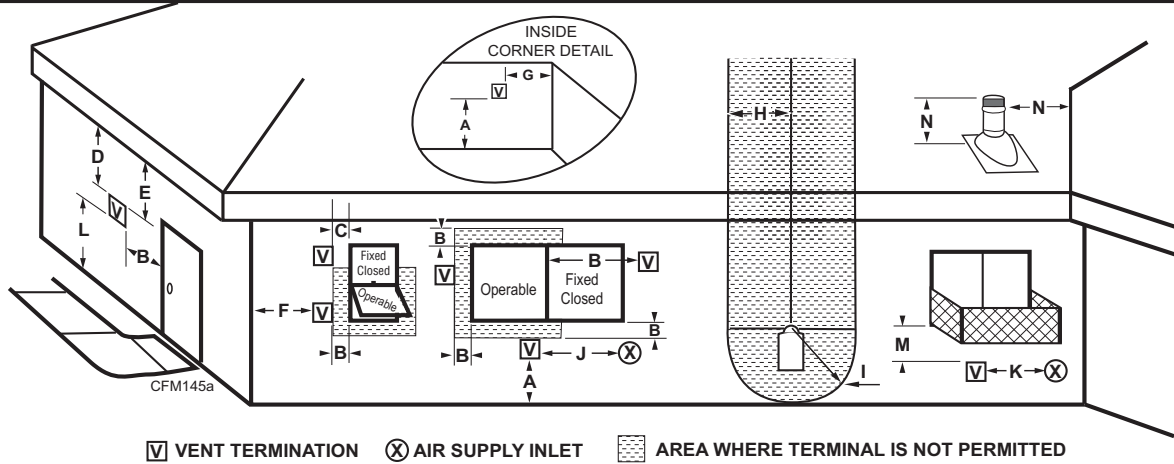

	Canadian Installations ¹	US Installations ²
A = Clearance above grade, veranda, porch, deck, or balcony	12" (30cm)	12" (30cm)
B = Clearance to window or door that may be opened	6" (15cm) for appliances < 10,000Btuh (3kW), 12" (30cm) for appliances > 10,000 Btuh (3kW) and < 100,000 Btuh (30kW), 36" (91cm) for appliances > 100,000 Btuh (30kW)	6" (15cm) for appliances < 10,000 Btuh (3kW), 9" (23cm) for appliances > 10,000 Btuh (3kW) and < 50,000 Btuh (15kW), 12" (30cm) for appliances > 50,000 Btuh (15kW)
C = Clearance to permanently closed window	12" (305mm) recommended to prevent window condensation	12" (305mm) recommended to prevent window condensation
D = Vertical clearance to ventilated soffit located above the terminal within a horizontal distance of 2' (610mm) from the center line of the terminal	18" (458mm)	18" (458mm)
E = Clearance to unventilated soffit	12" (305mm)	12" (305mm)
F = Clearance to outside corner	see next page	see next page
G = Clearance to inside corner (see next page)	see next page	see next page
H = Clearance to each inside of center line extended above meter/regulator assembly	3' (91cm) within a height of 15' (5m) above the meter/regulator assembly	3' (91cm) within a height of 15' (5m) above the meter/regulator assy
I = Clearance to service regulator vent outlet	3' (91cm)	3' (91cm)
J = Clearance to nonmechanical air supply inlet to building or the combustion air inlet to any other appliances	6" (15cm) for appliances < 10,000 Btuh (3kW), 12" (30cm) for appliances > 10,000 Btuh (3kW) and < 100,000 Btuh (30kW), 36" (91cm) for appliances > 100,000 Btuh (30kW)	6" (15cm) for appliances < 10,000 Btuh (3kW), 9" (23cm) for appliances > 10,000 Btuh (3kW) and < 50,000 Btuh (15kW), 12" (30cm) for appliances > 50,000 Btuh (15kW)
K = Clearance to a mechanical air supply inlet	6' (1.83m)	3' (91cm) above if within 10 feet (3m) horizontally
L = Clearance above paved sidewalk or paved driveway located on public property	7' (2.13m)†	7' (2.13m)†
M = Clearance under veranda, porch, deck or balcony	12" (30cm)‡	12" (30cm)‡

N = Clearance above a roof shall extend a minimum of 24" (610mm) above the highest point when it passes through the roof surface, and any other obstruction within a horizontal distance of 18" (450mm).

1 In accordance with the current CSA-B149 Installation Codes

2 In accordance with the current ANSI Z223.1/NFPA 54 National Fuel Gas Codes

† A vent shall not terminate directly above a sidewalk or paved driveway which is located between two single family dwellings and serves both dwellings

‡ only permitted if veranda, porch, deck or balcony is fully open on a minimum 2 sides beneath the floor:

NOTE: 1. Local codes or regulations may require different clearances.

2. The special venting system used on Direct Vent Fireplaces are certified as part of the appliance, with clearances tested and approved by the listing agency.

3. MHSC assumes no responsibility for the improper performance of the appliance when the venting system does not meet these requirements.

Fig. 10 Vent termination locations.

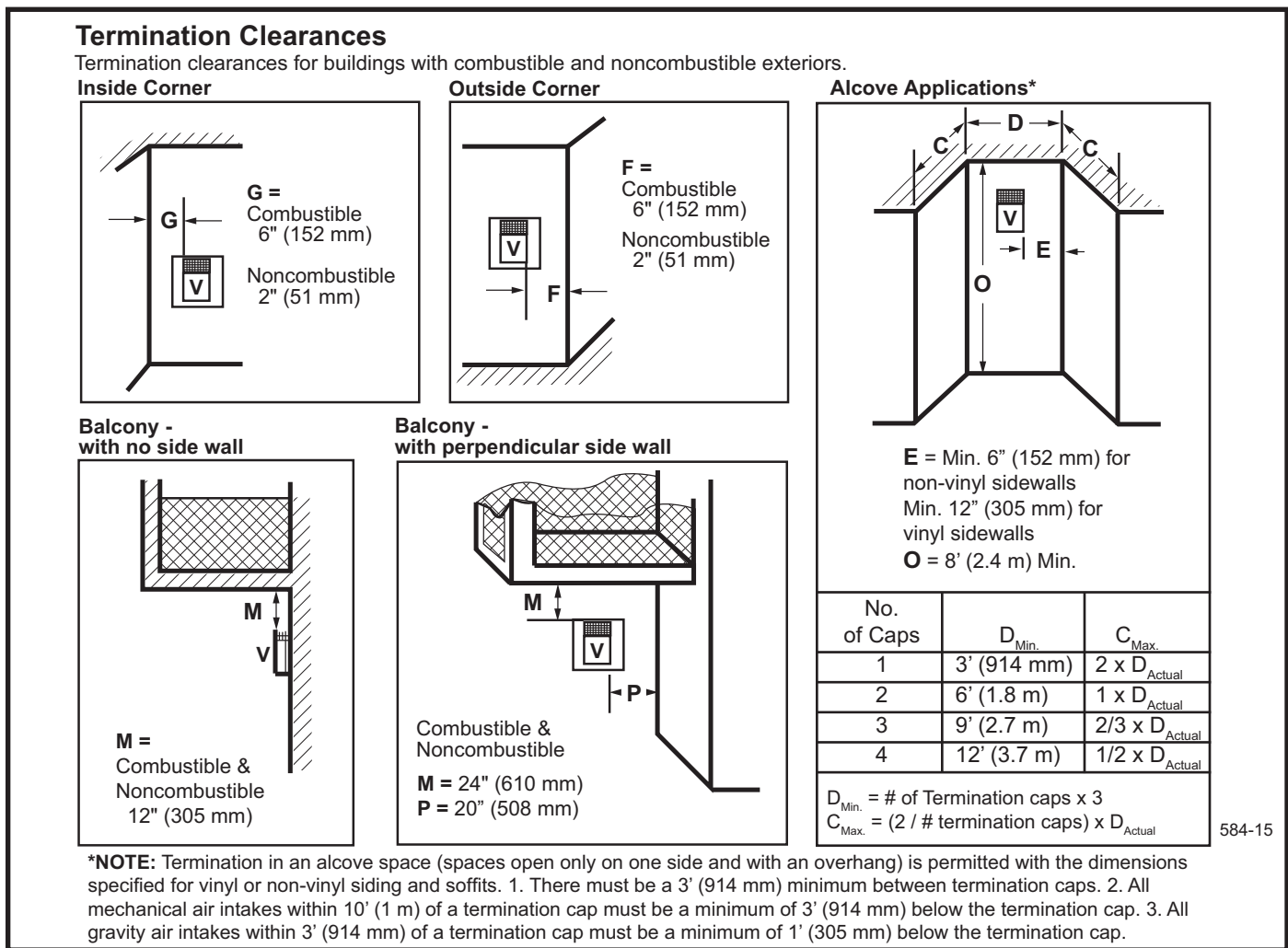

Fig. 11 Termination clearances.

General Information Assembling Vent Pipes

Canadian Installations:

Venting system must be installed in accordance with the current CSA-B149.1 installation code.

USA Installations:

The venting system must conform with local codes and/or the current National Fuel Gas code ANSI Z223.1/ NFPA 54.

Only venting components manufactured by MHSC can be used in Direct Vent systems.

Flex Vent Pipes

Before joining the flex vent pipe to the unit, apply a bead of high temperature sealant* (provided) to the 4" pipe exiting the fireplace. Secure flex vent pipe in place with a hose clamp (provided).

*Be sure the flex pipe overlaps at least 1" (25 mm) onto the collars of the fireplace and termination. If the termination has an internal bead, be sure to overlap and secure 1" (25 mm) past the bead.

* Be sure the vent is actually crushed before proceeding. Apply a tug to be sure the vent will not slip off the collars.

Repeat process with 7" flex vent pipe. The same procedure must be performed on the vent side.

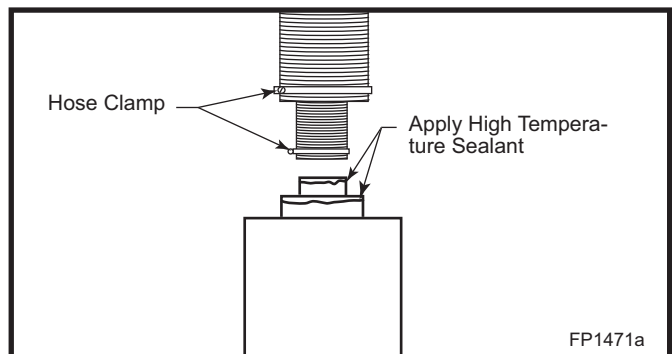

Fig. 12 Apply high temperature sealant to 4" and 7" pipes.

Twist Lock Pipes

When using MHSC twist-lock pipe, it is not necessary to use sealant on the joints. The only areas of the venting system that need to be sealed with high temperature silicone sealant are the sliding joint of any telescopic vent section used in the system.

To join the twist lock pipes together, simply align the beads of the male end with the grooves of the female end, then while bringing the pipe together, twist the pipe until the flange on the female end contacts the external flange on the male end. It is recommended that you secure the joints with three (3) sheet metal screws, however this is not mandatory with twist lock pipe.

To make it easier to assemble the joints we suggest putting a lubricant (Vaseline or similar) on the male end of the twist lock pipe prior to assembly.

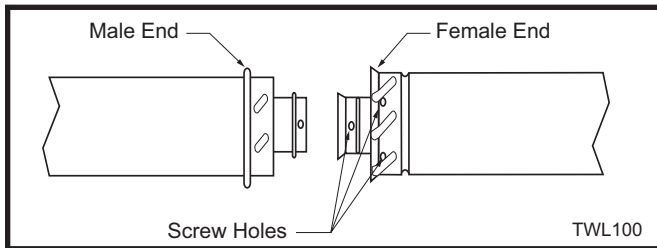

Fig. 13 Twist-lock pipe joints.

36CDVXR Venting

How to Use the Vent Graph

The vent chart should be read in conjunction with the following vent installation instructions to determine the relationship of the vertical and horizontal dimensions of the vent system.

1. Determine the height of the center of the horizontal vent pipe exiting through the outer wall. Using this dimension on the Sidewall Vent Graph (Fig. 14) locate the point intersecting with slanted graph line.
2. From the point of this intersection, draw a vertical line to the bottom of the graph.
3. Select the indicated dimension, and position the fireplace in accordance with same.

Example A:

If the vertical dimension from the floor of the fireplace is 11' (3.4 m) the horizontal run to the face of the outer wall must not exceed 14' (4.3 m).

Example B:

If the vertical dimension from the floor of the unit is 7' (2.14 m), the horizontal run to the face of the outer wall must not exceed 8½' (2.6 m).

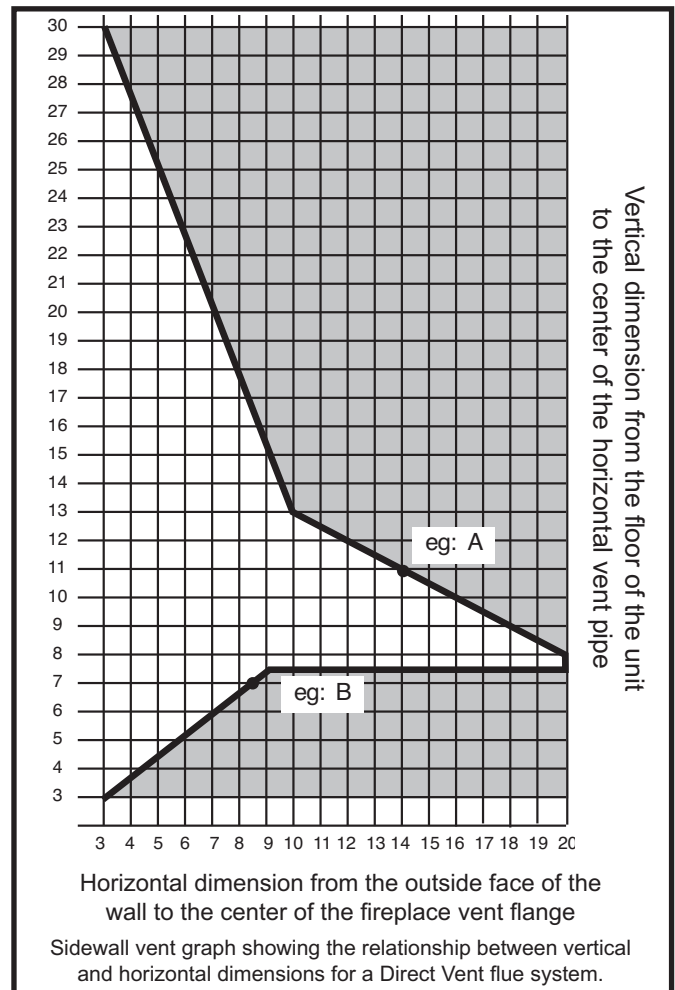

Fig. 14 Sidewall venting graph. (Dimensions in feet)

Rear Wall Venting Applications

* Exterior Outside Wall
7" (178 mm) to 20" (508 mm)
From Rear of Unit *

With this application, the following rigid pipe kits may be used:

- 7" to 13" (178 - 330 mm) to outside wall: 7TCRVTV
- 13" to 20" (330 - 305 mm) to outside wall: 7TCRVTV1320
- 45° elbow with 20" (508 mm) Starter for corner applications

When installed as a rear vent unit this appliance may be vented directly to a termination located on the rear wall behind the appliance.

- Only MHSC venting components are approved to be used in these applications. (Refer to "Venting Components" listed for different installation requirements)
- **The maximum straight out the back horizontal distance between the rear of the appliance and the outside face of the rear wall is 20" (508 mm). The minimum is 7" (178 mm). (Fig. 15)**

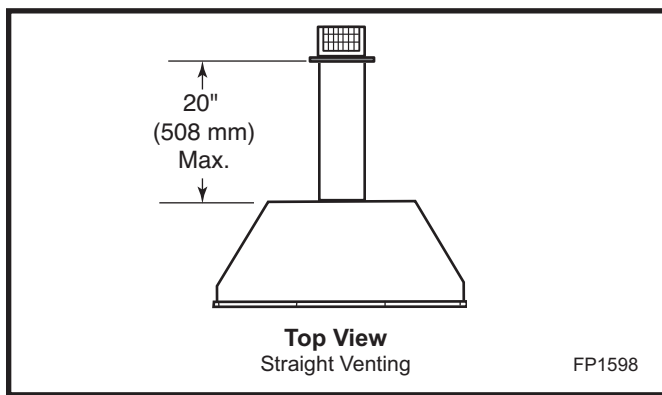

Fig. 15 Rear vent applications.

- Minimum clearances between vent pipe and combustible materials are as follows:
 Top - 1" (25 mm)
 Sides - 1" (25 mm)
 Bottom - 1" (25 mm)
- The maximum horizontal distance between the end of the transition elbow in a corner application and the outside face of the rear wall is 20" (508 mm). (Fig. 16)
- Only one 45° elbow is allowed in these installations.

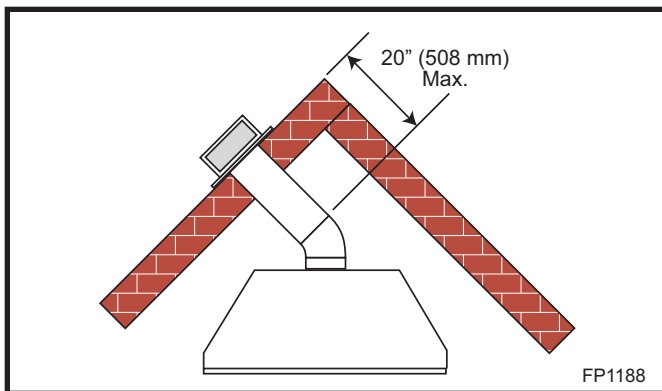

Fig. 16 Rear vent application, one 45° elbow.

Rear Wall Installation Twist Lock Pipe

STEP 1

Locate vent opening on the wall. To locate hole center consult with appropriate fireplace dimensions, Page 4. Frame as shown below.

Combustible Walls (Fig. 17): Cut a 9³/₈"H x 9³/₈" W (240 x 240 mm) hole through the exterior wall and frame as shown. For 7TCRVT1320 cut a 10³/₈"H x 9³/₈" W (264 x 240 mm) hole.

Noncombustible Walls (Fig. 17): Hole opening must be 7¹/₂" (190 mm) in diameter.

STEP 2

Install interior firestop as shown in Figure 18.

STEP 3

Remove telescoping collar from termination.

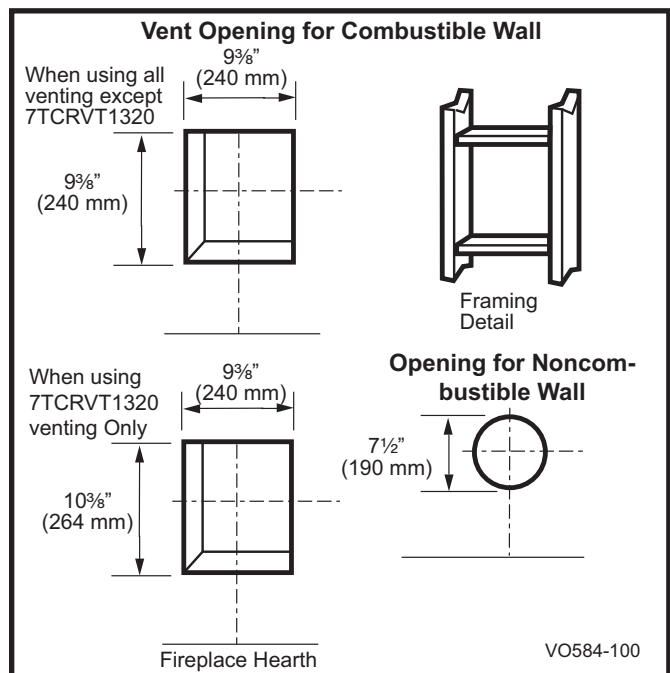

Fig. 17 Locate vent opening on wall.

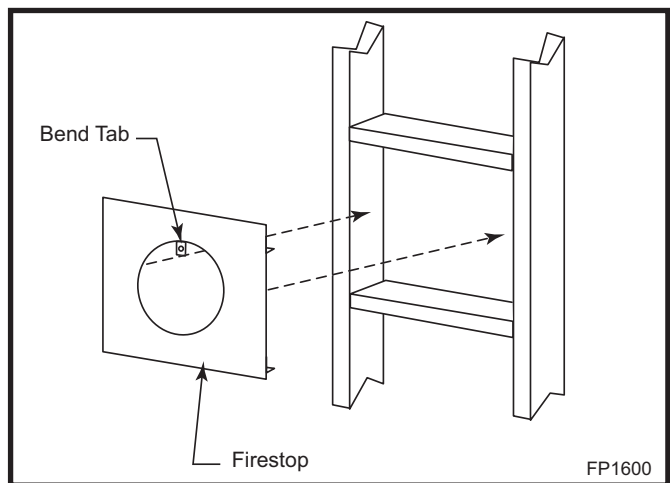

Fig. 18 Install firestop.

STEP 4

Bend tab on outer casing up and insert collar onto fireplace collars. (Fig. 18)

STEP 5

Twist the termination collar so it locks onto fireplace collars. Run screw through tab to keep collar from turning. (Fig. 19)

STEP 6

Slide fireplace into position.

STEP 7

From the outside of the house, slide the termination onto the collars.

STEP 8

Secure the termination to the house with the four (4) screws provided.

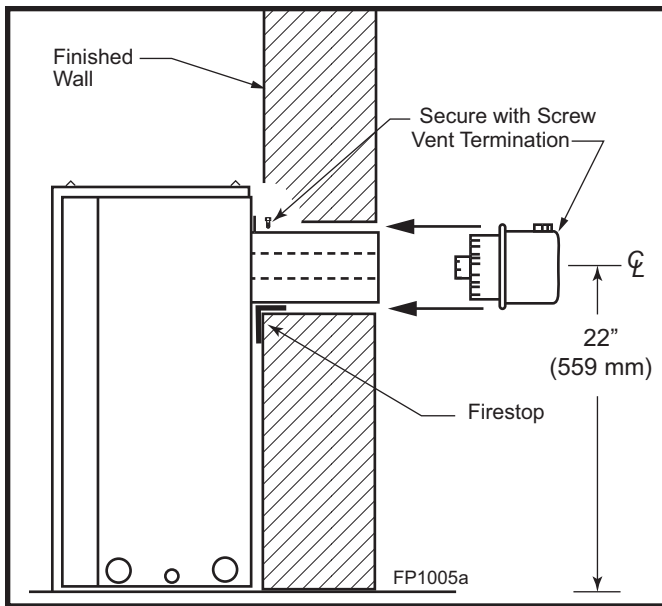

Fig. 19 Side view of final unit location.

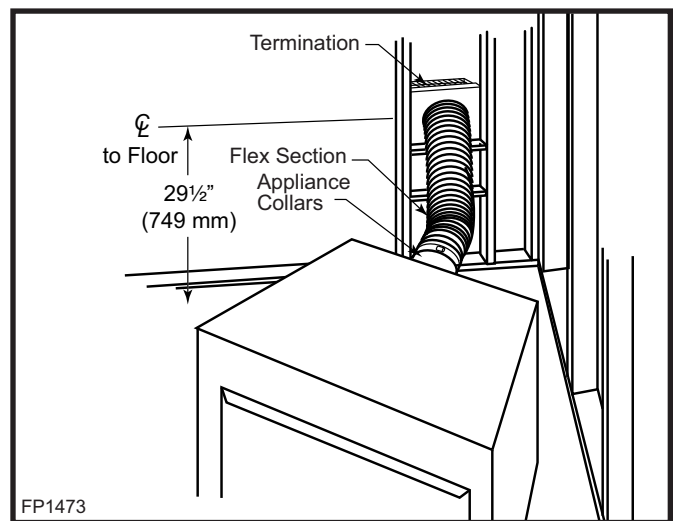

Fig. 20 Grasp the vent pipe close to the collar and bend to 45° angle. Do not exceed 45°.

Rear Wall Vent Installations - 45° Flex Vent Pipe Using Kit 7TCD45KT

NOTE: The corner placement dimensions on Page 4 of the manual must be adhered to! Figures 20 & 21 show general installations. Refer to instructions below for a detailed description of installation.

1. Determine where the termination is to be installed. **Locate the center of the hole 29½" (749 mm) off the floor. (Fig. 20)**

NOTE: The location of the termination hole must be adhered to!

2. Install the firestop as shown on Page 14.
3. Remove the flex vent and extend the flex vent out to its longest length.
4. Bend the tab on the back of the fireplace up. (Fig. 18)
5. Insert the collar on the flex vent that has the twist lock embosses on it onto the collar of the fire-

place. Twist the collar to "lock it" onto the fireplace. Run a screw through the tab and into the collar to secure the collar onto the fireplace.

6. Bend the flex pipe up 90° as close to the fireplace as possible. (Fig. 21)
7. Slide the fireplace partially into the corner and, while holding the vertical portion of the flex vent pipe, grab the exposed end collar and bend it down to the height of the opening in the wall.
8. While pushing the unit in place, slide the collar through the firestop. **NOTE:** It may be necessary to trim some material off of the collar. The collar is made long to accommodate brick finished houses. (Fig. 23)
9. Secure the collar in place by running a screw through the tab in the firestop and through the collar.
10. Slide the termination into the collar and secure with the 4 screws provided. (Fig. 23)

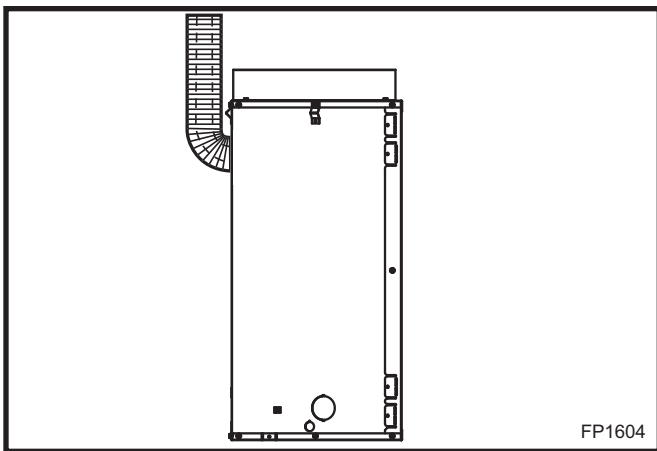

Fig. 21 Bend flex pipe up 90° as close to fireplace as possible.

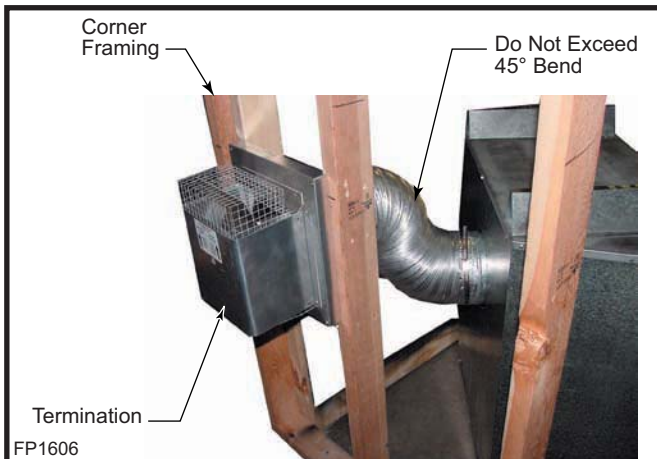

Fig. 22 Rear view of corner installation.

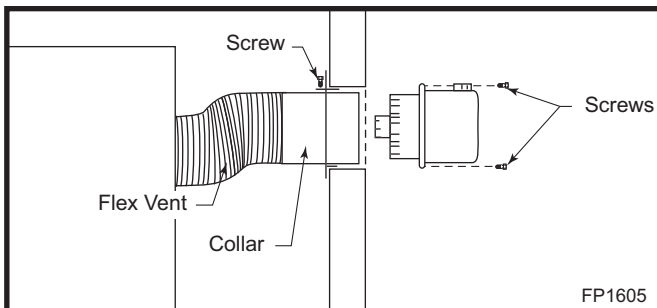

Fig. 23 Secure collar in place, slide termination into collar.

Rear Wall Vent Application
*** Exterior Outside Wall**
13" to 20" (330 - 508 mm)
From Rear of Unit * Using Flex Venting Kit

1. Determine the location of the termination. (Fig. 24)
IMPORTANT: Vent must have a 2½" (64 mm) rise for this application.
2. **Locate the hole 24½" (622 mm) off the floor.** This is the center line of the termination. Refer to "Rear Wall Installation Twist Lock Pipe" section.

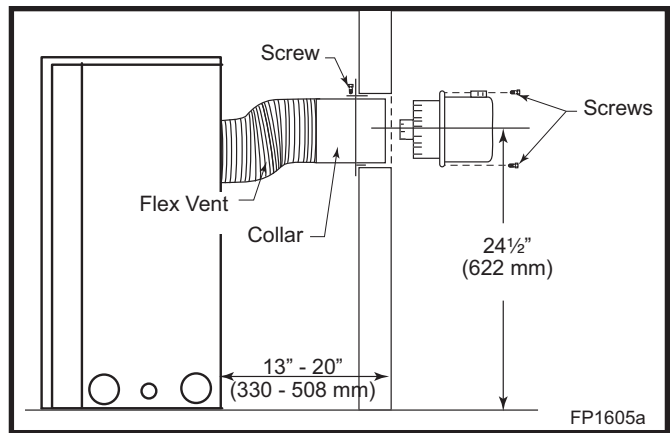

Fig. 24 The centerline of the termination must be 24½" (622 mm) off the floor.

3. Proceed with Step 3 of "Rear Wall Vent Application *Exterior Outside Wall 20" to 32" (508-813 mm) from Rear of Unit" section (below).

Rear Wall Vent Application
*** Exterior Outside Wall**
20" - 32" (508 - 813 mm)
From Rear of Unit * Using Flex Vent Kit
7TCD45KT

1. Determine where the termination is to be installed. (Fig. 25)
2. **Locate the hole 27¼" (692 mm) off the floor.** This is the center line of the termination. Refer to "Rear Wall Installation Twist Lock Pipe" section.

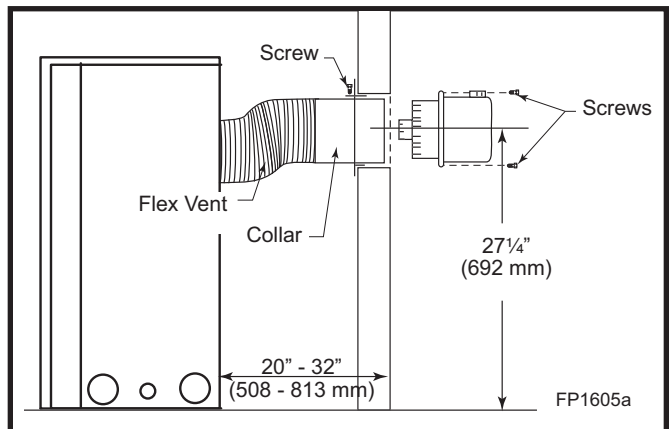

Fig. 25 The centerline of the termination must be 27¼" (692 mm) off the floor.

3. Mount the flex pipe assembly to the fireplace collars and twist the collar that the flex pipe is attached to onto the fireplace.
4. Once the collar is twisted onto the fireplace collar, secure with a screw through the tab. (Fig. 19)
5. While sliding the fireplace into position, lift up the end of the flex pipe and slip it through the firestop. *Be careful not to extend the flex too much. The flex pipe

needs to have an immediate rise before going horizontal. **NOTE:** Be careful not to distort the outer flex as this will affect the performance of the fireplace.

6. Secure the collar to the firestop by bending the tab out on the firestop and running a screw through the tab and collar.
7. From outside the house, slide the termination onto the collars sticking through the firestop.
8. Secure the termination to the house with the four (4) screws provided. Be sure to seal around the termination and house cladding.

Vertical Sidewall Applications



Since it is very important that the venting system maintain its balance between the combustion air intake and the flue gas exhaust, certain limitations as to vent configurations apply and must be strictly adhered to.

The Vent Graph shows the relationship between vertical and horizontal side wall venting and will help to determine the various dimensions allowable.



Minimum clearance between vent pipes and combustible materials is 1" (25 mm) on top, bottom and sides unless otherwise noted.

When vent termination exits through foundations less than 20" below siding outcrop, the vent pipe must flush up with the siding. It is always best to locate the fireplace in such a way that minimizes the number of offsets and horizontal vent length.

The horizontal vent run refers to the total length of vent pipe from the flue collar of the fireplace to the face of the outer wall.

Horizontal plane means no vertical rise exists on this portion of the vent assembly.

- The maximum horizontal vent run is 20 ft. (6.1 m) when the vertical vent rise is 7½ ft. (2.3 m). (Fig. 26)

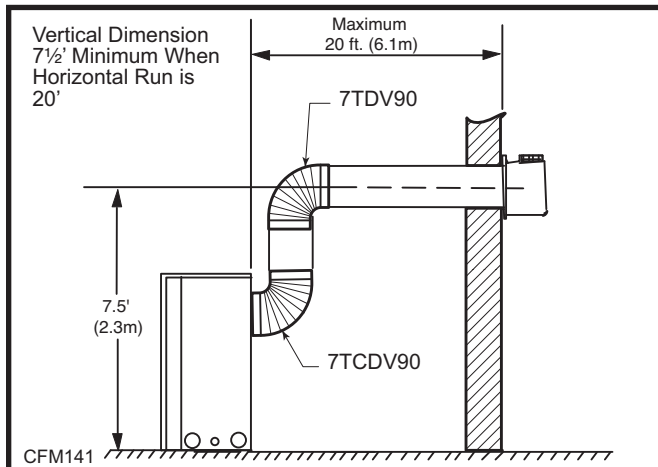

Fig. 26 Maximum number of 90° elbows is three (3).

- The maximum number of 90° elbows per side wall installation is three (3).
- If a 90° elbow is used in the horizontal vent run (level height maintained) the maximum horizontal vent length is reduced by 36" (914 mm). (Fig. 27) This does not apply if the 90° elbows are used to increase or redirect a vertical rise. (Fig. 28)

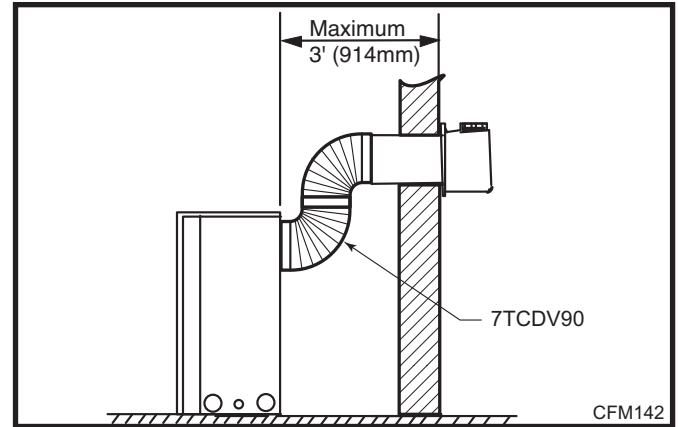

Fig. 27 Maximum horizontal vent run.

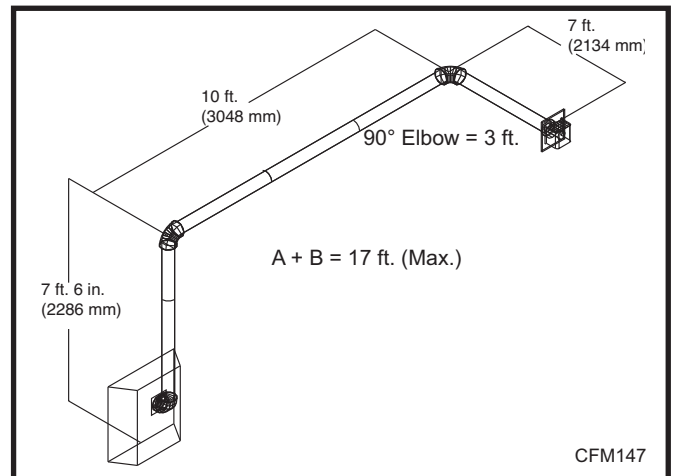

Fig. 28 Maximum vent run with elbows.

Example: According to the chart the maximum horizontal vent length in a system with a 7.5' (2.3 m) vertical rise is 20' (6 m) and if a 90° elbow is required in the horizontal vent it must be reduced to 17' (5.2 m). In Figure 28 Dimension A plus B must not be greater than 17' (5.2 m).

- The maximum number of 45° elbows permitted per side wall installation is two (2). These elbows can be installed in either the vertical or horizontal run.
- For each 45° elbow installed in the horizontal run, the length of the horizontal run MUST be reduced by 18" (45 cm). This does not apply if the 45° elbows are installed on the vertical part of the vent system.
- The maximum number of elbow degrees in a system is 270°. (Fig. 29)

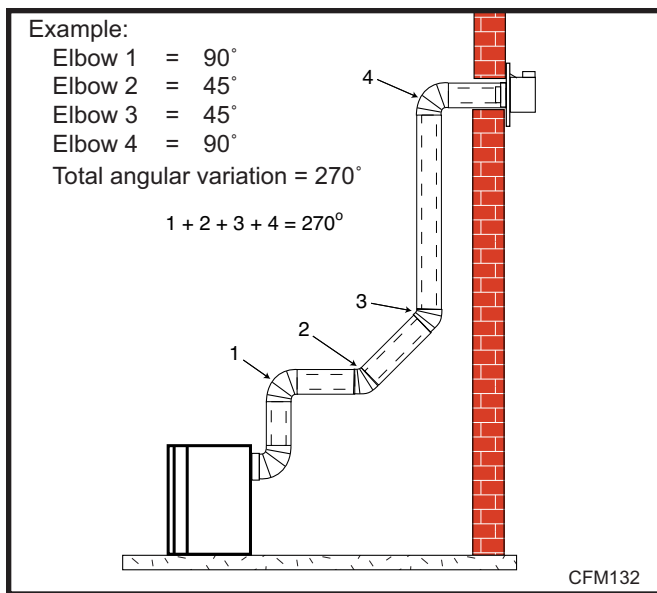

Fig. 29 Maximum number of elbows.

•IMPORTANT• Minimum clearance between vent pipes and combustible materials is one (1") inch (25 mm) on bottom, sides and top.

 **Twist Lock Vent Starter Kit 7TCRVT, plus Elbow 7TCDV90 must be used in Vertical Sidewall installations.**

Canadian & USA Installations:

The venting system must conform with local codes, or in the absence of local codes, with National Fuel Gas Code, ANSI Z223.1/NFPA 54 - latest edition, or CSA B149.1 Installation Code.

Only MHSC venting components specifically approved and labelled for this fireplace may be used.

Vertical Sidewall Installation

STEP 1

Locate vent opening on the wall. It may be necessary to first position the fireplace and measure to obtain hole location. Depending on whether the wall is combustible or noncombustible, cut opening to size. (Page 14, Fig. 17)

For combustible walls first frame in opening.

Combustible Walls (Fig. 17): Cut a 9 $\frac{3}{8}$ "H x 9 $\frac{3}{8}$ " W (240 x 240 mm) hole through the exterior wall and frame. For 7TCRVT1320 cut a 10 $\frac{3}{8}$ "H x 9 $\frac{3}{8}$ " W (264 x 240 mm) hole.

Noncombustible Walls (Fig. 17): Hole opening must be 7.5" (190 mm) in diameter.

STEP 2

Slide venting component on collar of fireplace. Secure component to fireplace by running a screw (self-tapping) through tab & into outer casing. (Fig. 30)

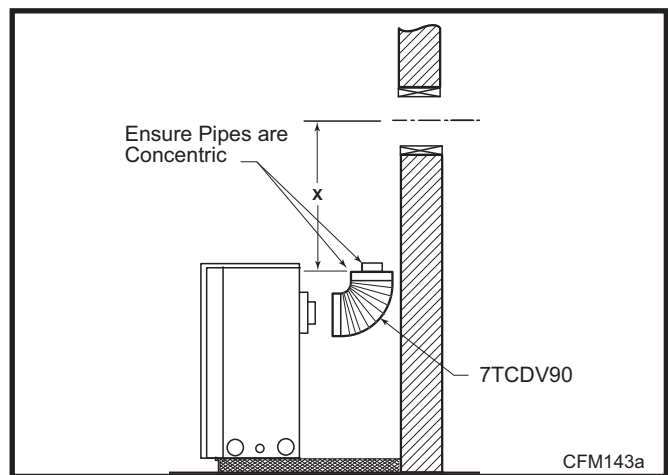

Fig. 30 Always start vertical run with 7TCDV90 on 36CDVR units.

STEP 3

Measure the horizontal length requirement including a 2" (51 mm) overlap, i.e. from the elbow to the outside wall finish plus 2", or the distance required if installing a second 90° elbow. (Fig. 31)

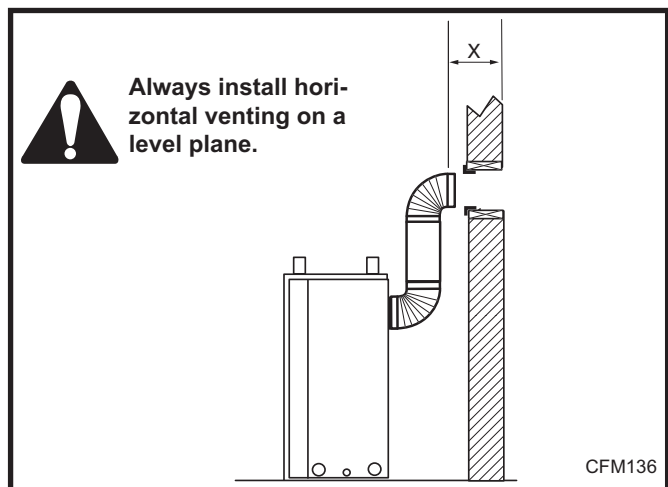



Fig. 31 Measure horizontal length including 2" overlap.

STEP 4

Use appropriate length of pipe section - telescopic or fixed - and install the horizontal vent sections. A starter section of pipe which goes through the wall is packaged with the 7TCRVT kit, and can be cut to suit if necessary. (Fig. 32)

 **Sealing between the vent pipe and firestop with high temperature sealant will restrict cold air being drawn in around fireplace.**

STEP 5

Guide the vent termination's 4" and 7" collars into their respective vent pipes. Double check that the vent pipes overlap the collars by 2" (51 mm). Secure the termination to the wall with screws provided and caulk around the wall plate to weatherproof. (Fig. 33)

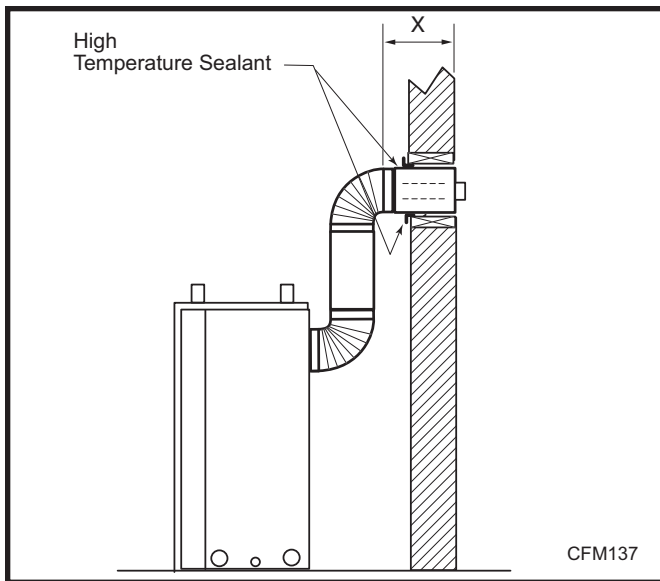

Fig. 32 Apply high temperature sealant.

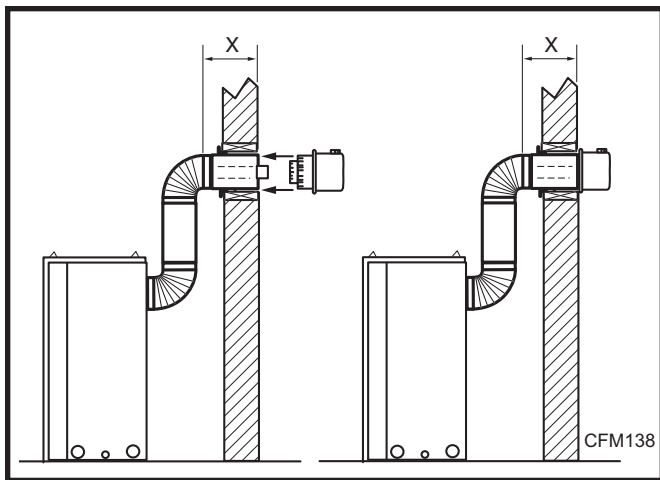

Fig. 33 Horizontal length requirement.

STEP 6

Support the horizontal pipes every 36" (914 mm) with metal pipe straps. Make sure that the horizontal vent pipe is installed on a level horizontal plane.

STEP 7

Re-check the fireplace to make sure that it is levelled, properly positioned, and nailed or screwed to the floor. If applied, the fireplaces adjustable frame drywall strips (nailing flanges) should be fastened. Refer to "Framing & Finishing".

Below Grade Installation

When it is not possible to meet the required vent terminal clearances of 12" (305 mm) above grade level a snorkel vent kit #7TDVSNORK is required. It allows installation depth of down to 7" (178 mm) below grade level. The 7" is measured from the center of the horizontal vent pipe as it penetrates through the wall.

! If venting system is installed below ground, we recommend a window well with adequate and proper drainage.

Ensure sidewall venting clearances are observed.

! The maximum horizontal run with 24" vertical rise is 36" (914 mm) from the back of the fireplace to the face of the exterior wall. See vent graph (Page 13) for extended horizontal run if the vertical rise exceeds 24" (610 mm).

1. Establish vent hole through the wall. (Fig. 17)
2. Remove soil to a depth of approximately 16" (406mm) below base of snorkel. Install window well (not supplied). Refill hole with 12" (305 mm) of coarse gravel leaving a clearance of approximately 4" (102 mm) below snorkel. (Fig. 34)
3. Install vent system. See Page 14, Steps 2 through 5.
4. Ensure a watertight seal is made around the vent pipe coming through the wall.
5. Apply high temperature sealant caulking around the 4" and 7" snorkel collars.
6. Slide into the vent pipe and secure to the wall.
7. Level the soil to maintain a 4" (102 mm) clearance below snorkel. (Fig. 34)

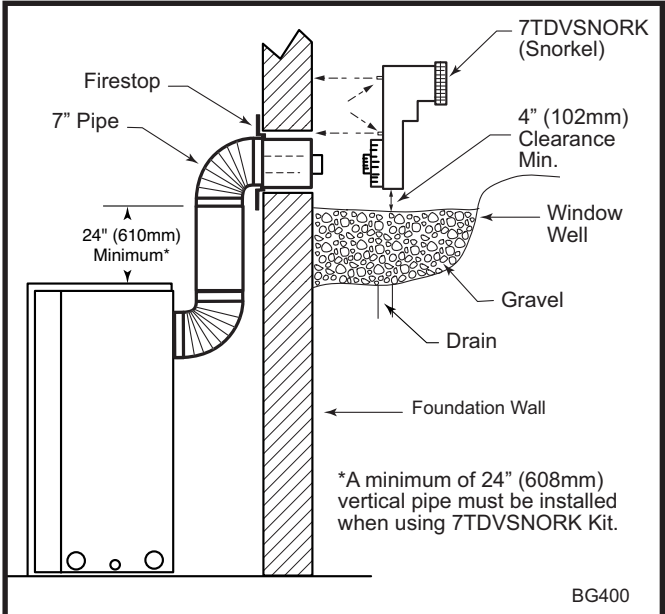

Fig. 34 Below grade installation.



Do not back fill around snorkel. A clearance of at least 4" (102 mm) must be maintained between the snorkel and the soil.

If the foundation is recessed, use recess brackets (not supplied) for securing lower portion of the snorkel. Fasten brackets to wall first, then secure to snorkel with self drilling #8 x 1/2 sheet metal screws. It will be necessary to extend vent pipes out as far as protruding wall face. (Fig. 35)

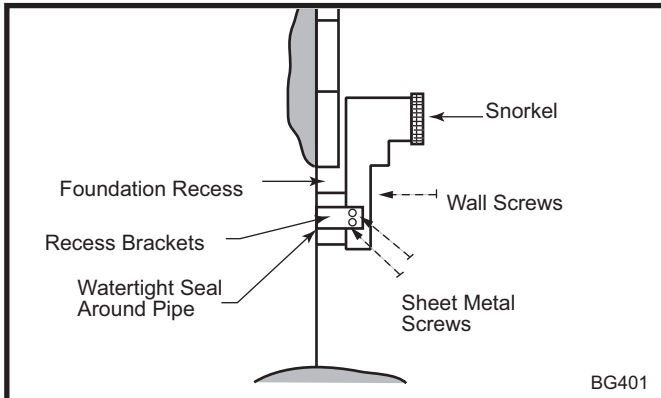

Fig. 35 Snorkel installation, recessed foundation.

Vertical Through-the-Roof Applications

This Gas Fireplace has been approved for:

1. Vertical installations up to 40' (12 m) in height. Up to 10' (3 m) horizontal vent run can be installed within the vent system using a maximum of three 90° elbows.
2. Up to two 45° elbows may be used within the horizontal run. For each 45° elbow used on the horizontal level the maximum horizontal length must be reduced by 18" (457 mm).

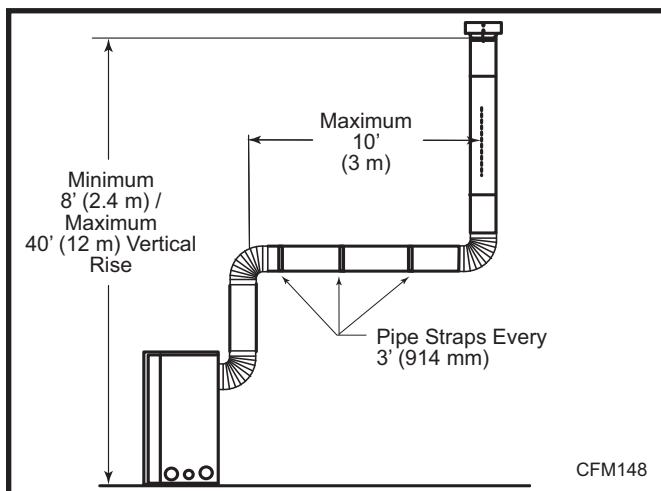

Fig. 36 Support straps for horizontal runs.

Example: Maximum horizontal length

- 0 x 45° elbows = 10' (3 m)
- 1 x 45° elbows = 8½' (2.6 m)
- 2 x 45° elbows = 7' (2.1 m)

3. A minimum of an 8' vertical rise.
4. Two sets of 45° elbows offsets within these vertical installations. From 0 to a maximum of 8' (2.4 m) of vent pipe can be used between elbows. (Fig. 37)
5. 7DVCS must be used to support offsets. (Fig. 36) This application will require that you first determine the roof pitch and use the appropriate 7DVSKV (A, B or F). (Refer to Venting Components List, Page 27)

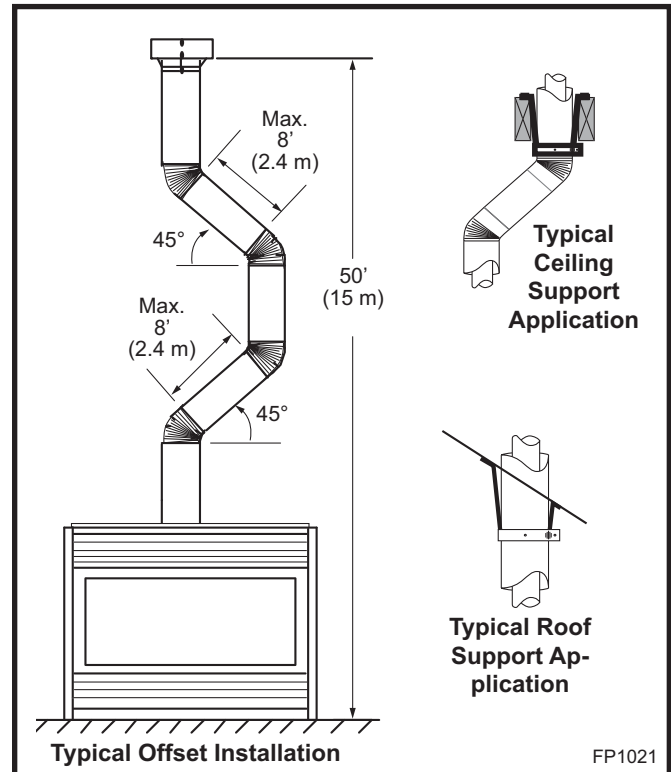

Fig. 37 Typical vertical roof applications.

Vertical Through-the-Roof Installation

1. Locate your fireplace.
2. Plumb to center of the (4") flue collar from ceiling above and mark position.
3. Cut opening equal to 9⅝" x 9⅝" (240 x 240 mm). 10⅝" x 9⅝" (264 x 240 mm) when using 7TCRVT1320.
4. Proceed to plumb for additional openings through the roof. In all cases, the opening must provide a minimum of 1 inch clearance to the vent pipe, i.e., the hole must be at least 9⅝" x 9⅝" (240 x 240 mm).
5. Place fireplace into position.
6. Place firestop(s) #7DVFS or Attic Insulation Shield #7DVAIS into position and secure. (Fig. 38)

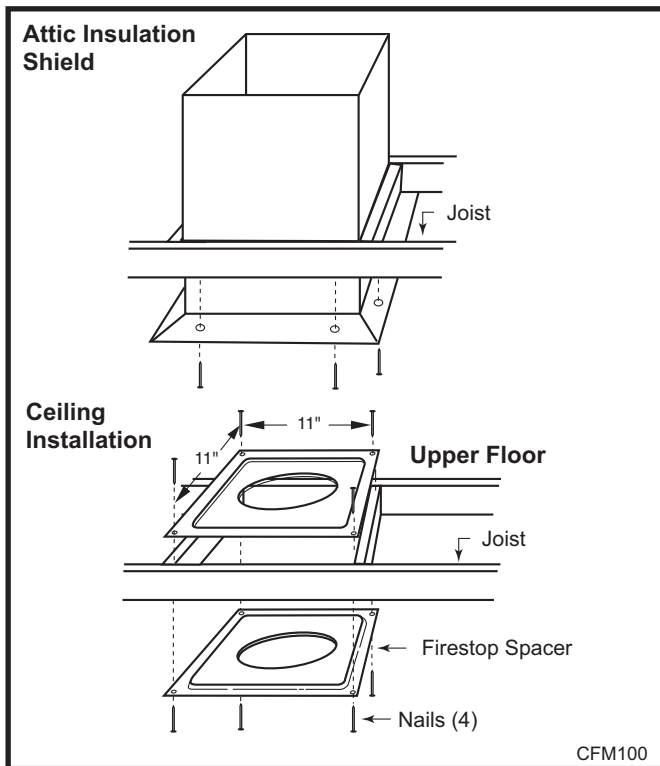

Fig. 38 Place firestop spacer(s) and secure.



If there is room above ceiling level, firestop spacer must be installed on both the bottom and the top side of the ceiling joists. If an attic is above ceiling level a 7DVAIS (Attic Insulation Shield) must be installed. (Fig. 38)

7. Install roof support (Fig. 39) and roof flashing making sure upper flange is below the shingles. (Fig. 40)
8. Install appropriate pipe sections until the venting is above the flashing. (Fig. 40)
9. Install storm collar and seal around the pipe.
10. Add additional vent lengths for proper height. (Fig. 41)

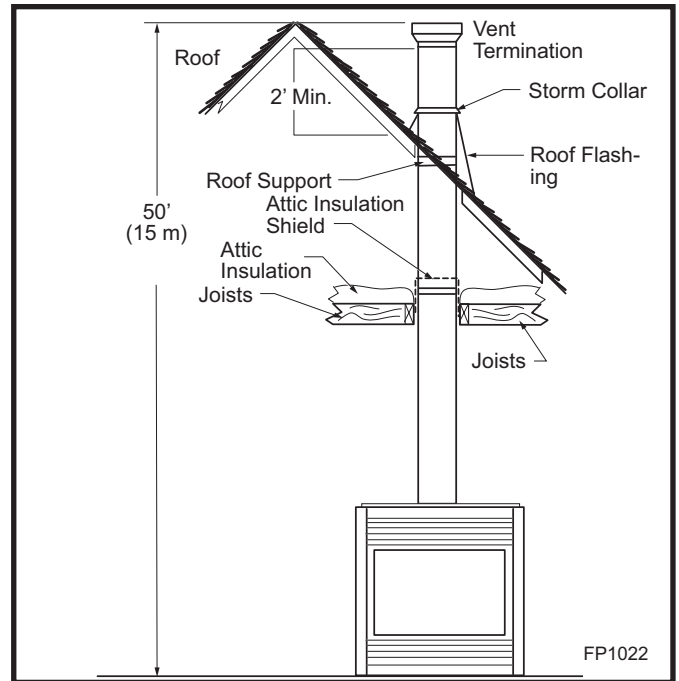

Fig. 39 Typical straight-up installation.

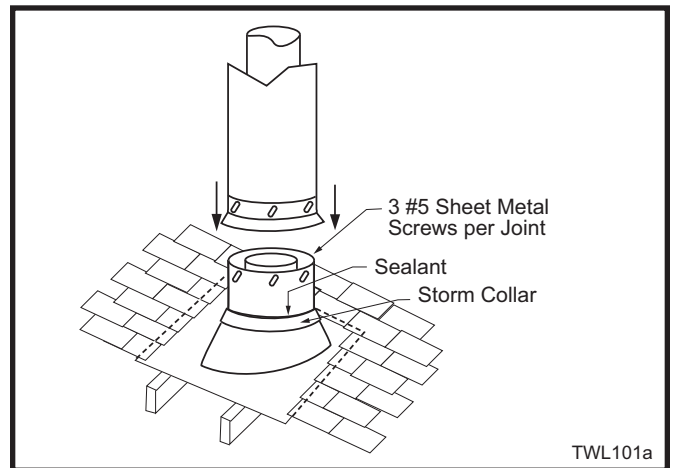

Fig. 40 Roof flashing.



The enlarged ends of the vent section always face down. (Fig. 37)

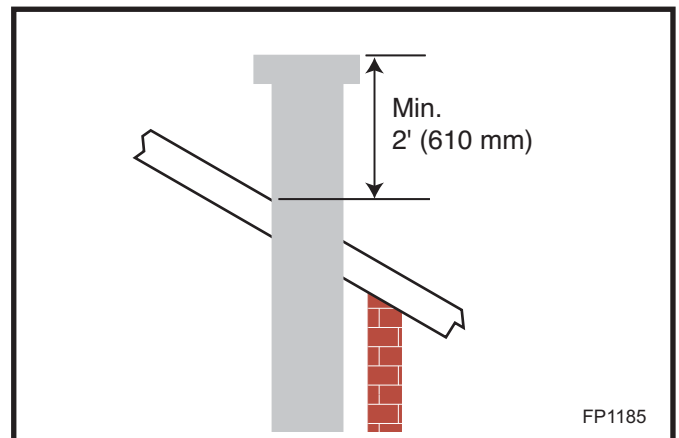

Fig. 41 Minimum termination to roof clearance.

36CDVXT Vertical Venting

How to Use the Vent Graph

The vent chart should be read in conjunction with the following vent installation instructions to determine the relationship of the vertical and horizontal dimensions of the vent system.

1. Determine the height of the center of the horizontal vent pipe exiting through the outer wall. Using this dimension on the Sidewall Vent Graph (Fig. 42), locate the point intersecting with the slanted graph line.
2. From the point of this intersection, draw a vertical line to the bottom of the graph.
3. Select the indicated dimension, and position the fireplace in accordance with same.

Example A:

If the vertical dimension from the floor of the fireplace is 11' (3.4 m) the horizontal run to the face of the outer wall must not exceed 14' (4.3 m).

Example B:

If the vertical dimension from the floor of the unit is 7' (2.14 m), the horizontal run to the face of the outer wall must not exceed 8½' (2.6 m).

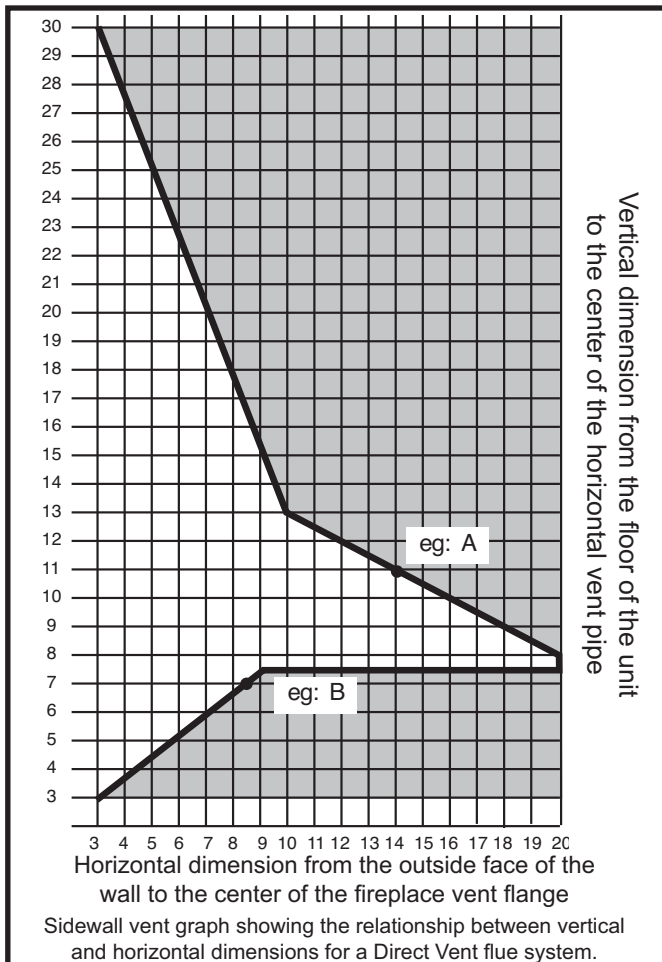

Fig. 42 Sidewall venting graph. (Dimensions in feet)
22

36 CDVXT Top Vent Baffle

The 36CDVXT is shipped with a restrictor installed in the unit. This allows for a better flame when installing a vertical venting configuration. Below is a rough estimate of opening positions based on vent length. This is a guide. More fine tuning can be done by a qualified installer. Adjust the restrictor so there is no lifting of the flame from the burner tube and the flame is not dirty to create soot.

To adjust:

1. Loosen the two (2) screws securing the flue baffle. (Fig. 43)
2. Remove two (2) screws from either side of the flue box. (Fig. 43) Adjust the restrictor. (Fig. 44)
3. Tighten the screws in the flue baffle and insert the two (2) screws removed earlier through the slots in the restrictor.

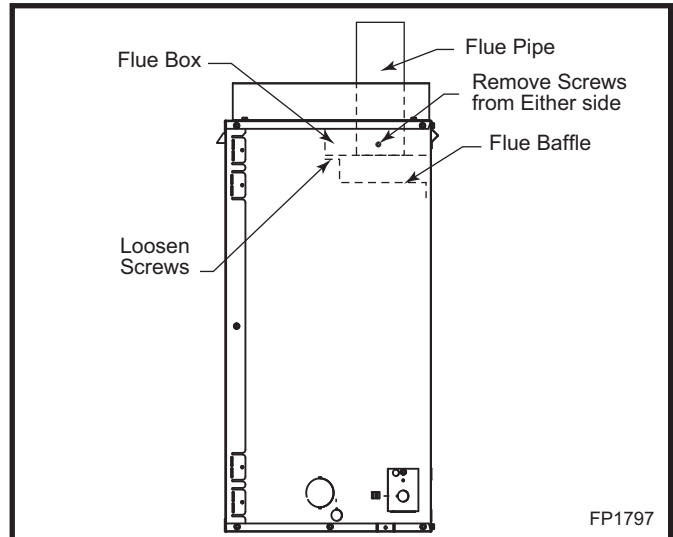

Fig. 43 Loosen screws securing flue baffle.

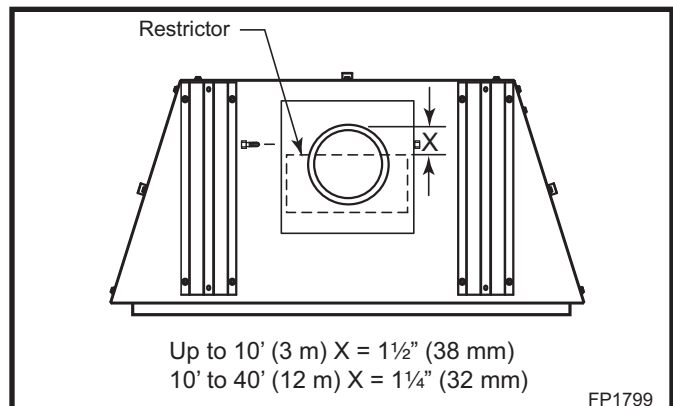

Fig. 44 Adjust the restrictor for best flame appearance.

Vertical Sidewall Applications



Since it is very important that the venting system maintain its balance between the combustion air intake and the flue gas exhaust, certain limitations as to vent configurations apply and must be strictly adhered to.

The vent graph showing the relationship between vertical and horizontal side wall venting will help to determine the various dimensions allowable.



Minimum clearance between vent pipes and combustible materials is one 1" (25 mm) on top, bottom and sides unless otherwise noted.

When the vent termination exits through foundations less than 20" (508 mm) below siding outcrop, the vent pipe must flush up with the siding.

It is always best to locate the fireplace in such a way that minimizes the number of offsets and horizontal vent length. The horizontal vent run refer to the total length of vent pipe from the flue collar of the fireplace to the face of the outer wall.

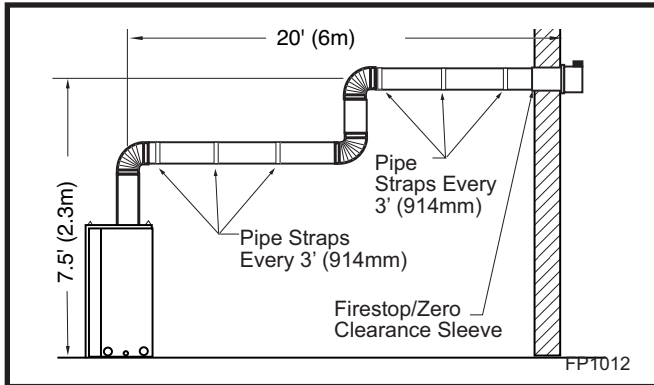

Fig. 45 Support straps for horizontal runs.

Horizontal plane means no vertical rise exists on this portion of the vent assembly.

- The maximum number of 90° elbows per side wall installations is three (3).
- If a 90° elbow is fitted directly onto the fireplace flange the maximum horizontal vent run before the termination or a vertical rise is 36" (914 mm).
- If a 90° elbow is used in the horizontal vent run (level height maintained) the maximum horizontal vent length is reduced by 36" (914 mm). This does not apply if the 90° elbows are used to increase or redirect a vertical rise.

Example: According to the chart the maximum horizontal vent length in a system with a 7.5' (2.3 m) vertical rise is 20' (6 m) and if a 90° is required in the horizontal vent it must be reduced to 17' (5.2 m). In Figure 46, Dimension A plus B must not be greater than 17' (5.2 m).

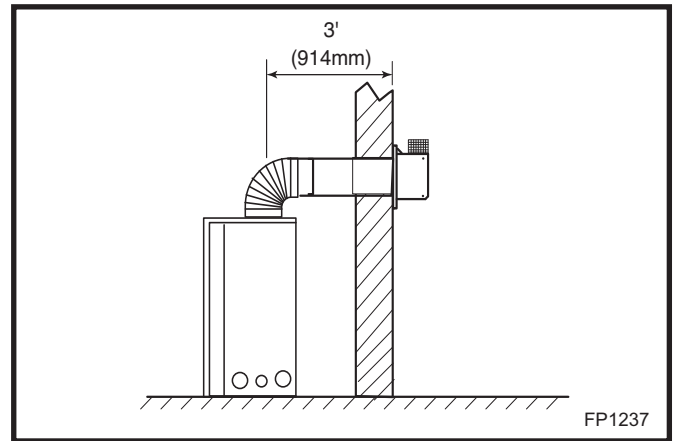

Fig. 46 Maximum horizontal vent run.

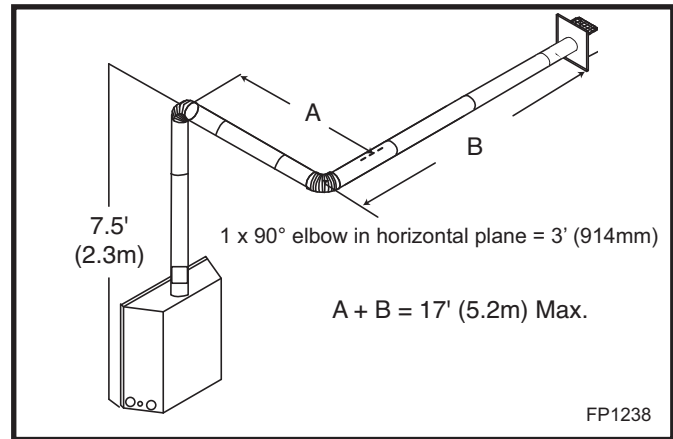

Fig. 47 Maximum vent run with elbows.

- The maximum number of 45° elbows permitted per side wall installation is two (2). These elbows can be installed in either the vertical or horizontal run.
- For each 45° elbow installed in the horizontal run, the length of the horizontal run **MUST** be reduced by 18" (457 mm). This does not apply if the 45° elbows are installed on the vertical part of the vent system.
- The maximum number of elbow degrees in a system is 270°. (Fig. 48)

Vertical Sidewall Installations

STEP 1

Locate vent opening on the wall. It may be necessary to first position the fireplace and measure to obtain hole location. Depending on whether the wall is combustible or noncombustible, cut opening to size. (Fig. Page 13, Fig. 17)

For combustible walls first frame in opening.

Combustible Walls: (Fig. 17) Cut a 9³/₈"H x 9³/₈"W (240 x 240 mm) hole through the exterior wall and frame as shown. or 7TCRVT1320 cut a 10³/₈"H x 9³/₈" W (264 x 240 mm) hole.

Noncombustible Walls: (Fig. 17) Hole opening must be 7¹/₂" (190 mm) in diameter.

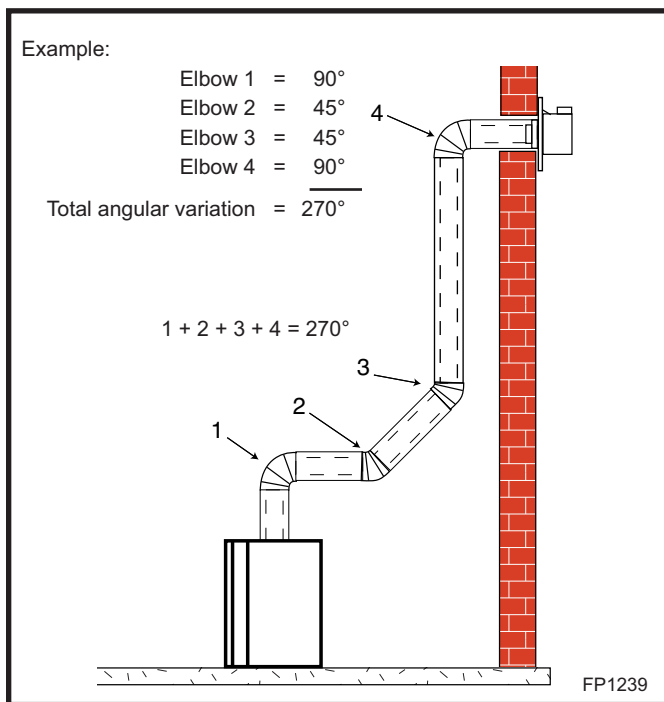

Fig. 48 Maximum number of elbow degrees.

STEP 2

Place fireplace into position. (Fig. 49) Measure the vertical height (X) required from the base of the flue collars to the center of the wall opening.

STEP 3

Attach appropriate venting component(s) to the fireplace with three (3) screws. (Fig. 50) Follow with the installation of the inner and outer elbow. Again secure joints with three (3) sheet metal screws.

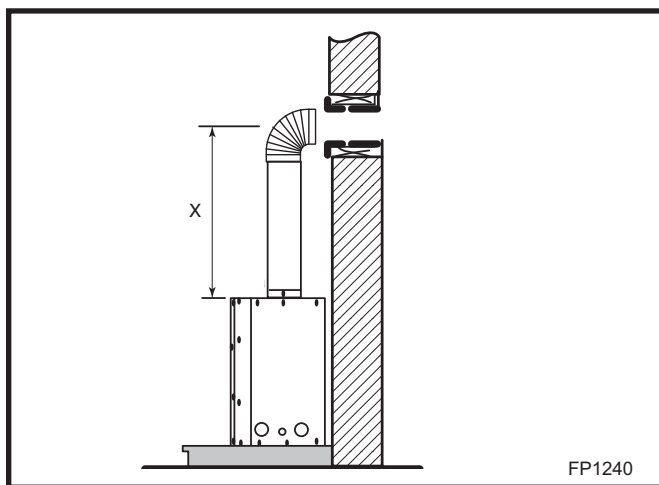

Fig. 49 Vertical height requirement.

STEP 4

Measure the horizontal length requirement including a 2" (51 mm) overlap, ie from the elbow to the outside wall face plus 2" (51 mm) (or the distance required if installing a second 90° elbow). (Fig. 50)

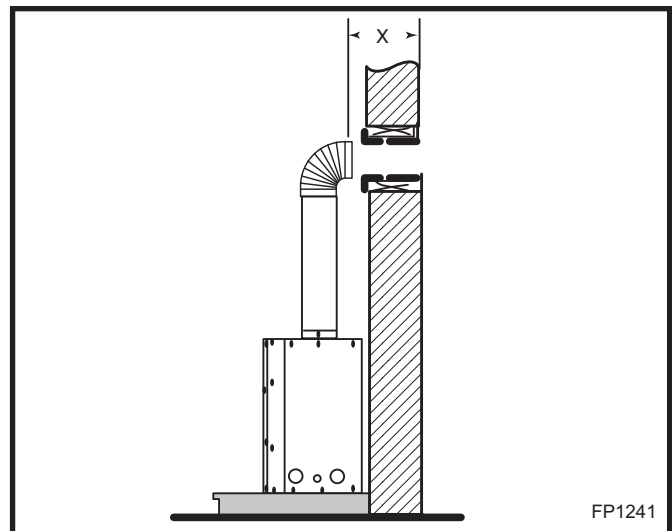

Fig. 50 Horizontal length requirement.



Always install horizontal venting on a level plane.

STEP 5

Use appropriate length of pipe sections - telescopic or fixed - and install the horizontal vent sections. The sections which go through the wall are packaged with the starter kit, and can be cut to suit if necessary. (Fig. 48)



Sealing the gaps between the vent pipe and firestop with high temperature sealant will restrict cold air being drawn in around fireplace.

STEP 6

Guide the vent terminations 4" and 7" collars into their respective vent pipes. Double check that the vent pipes overlap the collars by 2" (51 mm). Secure the termination to the wall with screws provided and caulk around the wall plate to weatherproof. (Fig. 52) As an alternative to screwing the termination directly to the wall you may also use expanding plugs or an approved exterior construction adhesive. You may also attach the termination with screws through the inner body into the 4" (102 mm) vent pipe however for this method you must extend the 4" (102 mm) pipe approximately 6" (152 mm) beyond the outer face of the wall.

Support horizontal pipes every 3' (914 mm) with metal pipe straps. Make sure the horizontal vent pipe is installed on a level horizontal plane.

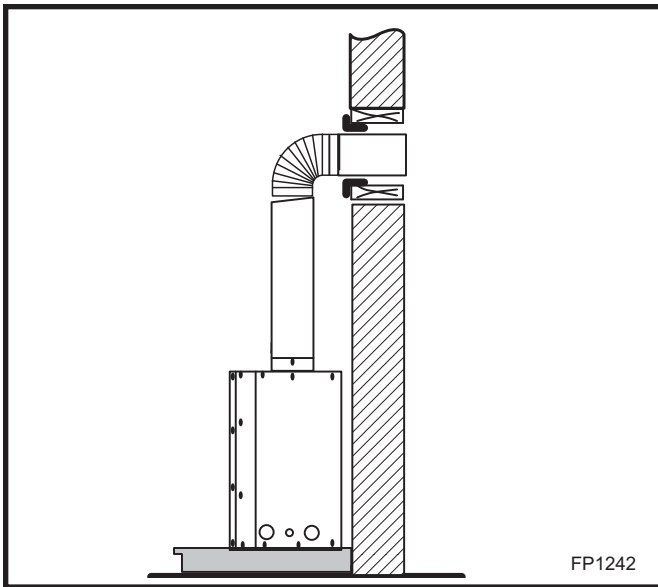

Fig. 51 Through the wall.

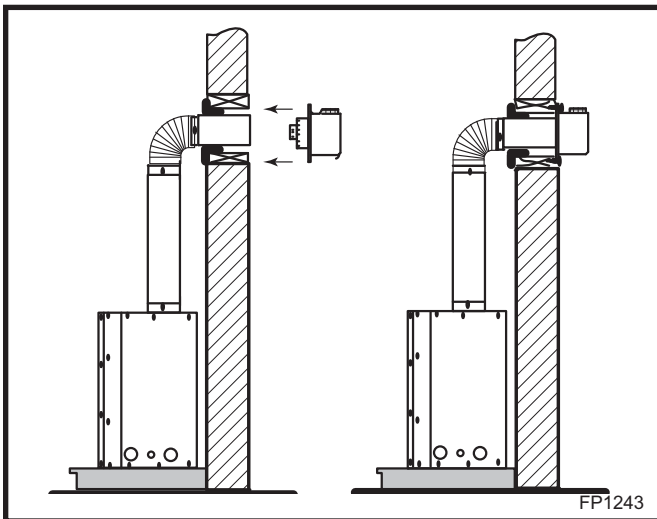

Fig. 52 Apply high temperature sealant to collars or terminations.

Below Grade Installations

When it is not possible to meet the required vent terminal clearances of 12" (305 mm) above grade level a snorkel vent kit is recommended. It allows installation depth of down to 7" (178 mm) below grade level. The 7" is measured from the center of the horizontal vent pipe as it penetrates through the wall.



If venting system is installed below ground, we recommend a window well with adequate and proper drainage.

Ensure sidewall venting clearances are observed.

If installing a snorkel a minimum 24" (610 mm) vertical rise is necessary. The maximum horizontal run with the 24" (610 mm) vertical pipe is 36" (914 mm). This measurement is taken from the collar of the fireplace (or transition elbow) to the face of the exterior wall. Refer to the Sidewall Vent Graph for extended horizontal run if the vertical rise exceeds 24" (610 mm).

1. Establish vent hole through the wall. (Page 14, Fig. 17)
2. Remove soil to a depth of approximately 16" (406 mm) below base of snorkel. Install drain pipe. Install window well (not supplied). Refill hole with 12" (305 mm) of coarse gravel leaving a clearance of approximately 4" (102 mm) below snorkel. (Fig. 53)
3. Install vent system.
4. Ensure a watertight seal is made around the vent pipe coming through the wall.
5. Apply high temperature sealant caulking around the 4" and 7" snorkel collars.
6. Slide the snorkel into the vent pipes and secure to the wall.
7. Level the soil to maintain a 4" (102 mm) clearance below snorkel. (Fig. 53)



Do not back fill around snorkel. A clearance of at least 4" (102 mm) must be maintained between snorkel and the soil.

If the foundation is recessed, use recess brackets (not supplied) for securing lower portion of the snorkel. Fasten brackets to wall first, then secure to snorkel with self drilling #8 x 1/2 sheet metal screws. It will be necessary to extend vent pipes out as far as protruding wall face. (Fig. 54)

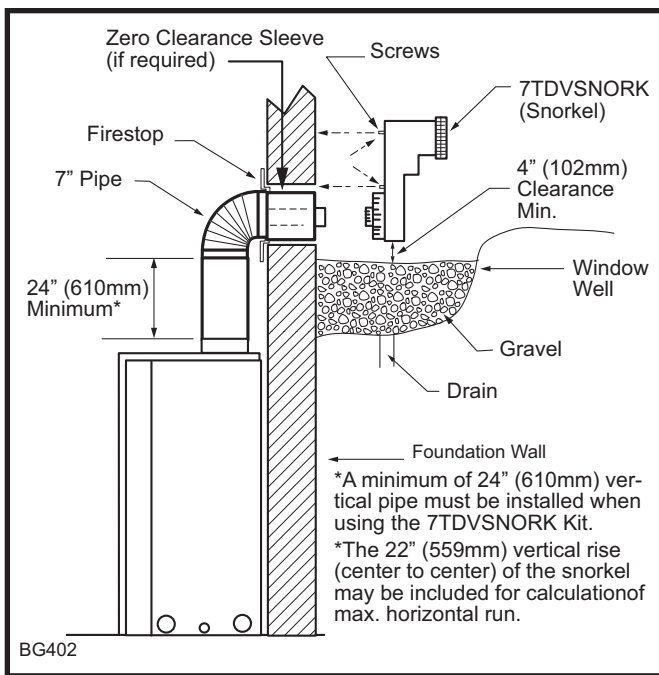

Fig. 53 Below grade installation.

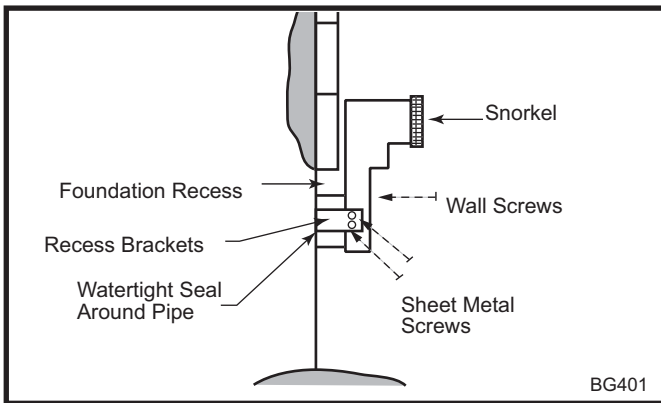

Fig. 54 Snorkel installation, recessed foundation.

Vertical Through-the-Roof Applications

This Gas Fireplace has been approved for:

- Vertical installations up to 40' (12 m) in height. Up to a 10' (3 m) horizontal vent run can be installed within the vent system using a maximum of two 90° elbows. (Fig. 55)
- Up to two 45° elbows may be used within the horizontal run. For each 45° elbow used on the horizontal level the maximum horizontal length must be reduced by 18" (457 mm).
Example: Maximum horizontal length
0 x 45° elbows = 10' (3 m)
1 x 45° elbows = 8½' (2.6 m)
2 x 45° elbows = 7' (2.1 m)
- A minimum of an 8' (2.4 m) vertical rise.

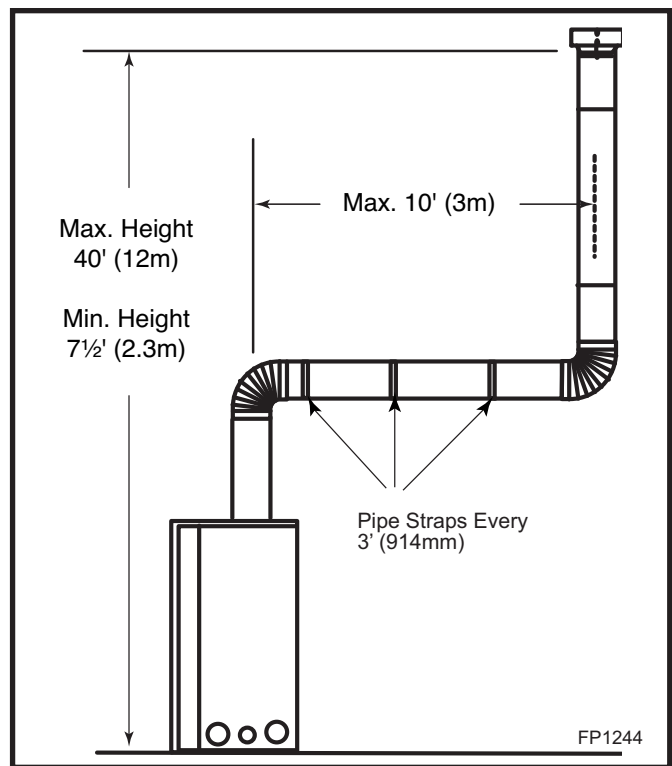

Fig. 55 Support straps for horizontal runs.

- Two sets of 45° elbows offsets within these vertical installations. From 0 to a maximum of 8' (2.m) of vent pipe can be used between elbows. (Fig. 56)
- 7DVCS must be used to support offsets. (Fig. 58) This application will require that you first determine the roof pitch and use the appropriate starter kit. (Refer to Venting Components List)
- The minimum height of the vent above the highest point of penetration through the roof is 2' (610 mm). (Fig. 60)

Vertical Through-the-Roof Installation

1. Locate your fireplace.
2. Plumb to center of the (4" (102 mm) flue collar from ceiling above and mark position.
3. Cut opening equal to 9⅞" x 9⅞" (240 x 240 mm). 10⅜" x 9⅞" (264 x 240 mm) when using 7TCRVT1320.
4. Proceed to plumb for additional openings through the roof. In all cases, the opening must provide a minimum of 1" (25 mm) clearance to the vent pipe, i.e., the hole must be at least 9⅞" x 9⅞" (240 x 240 mm).
5. Place fireplace into position.
6. Place firestop(s) #7DVFS or Attic Insulation Shield #7DVAIS into position and secure. (Fig. 57)
7. Install roof support (Fig. 58) and roof flashing making sure upper flange of flashing is below the shingles. (Fig. 59)

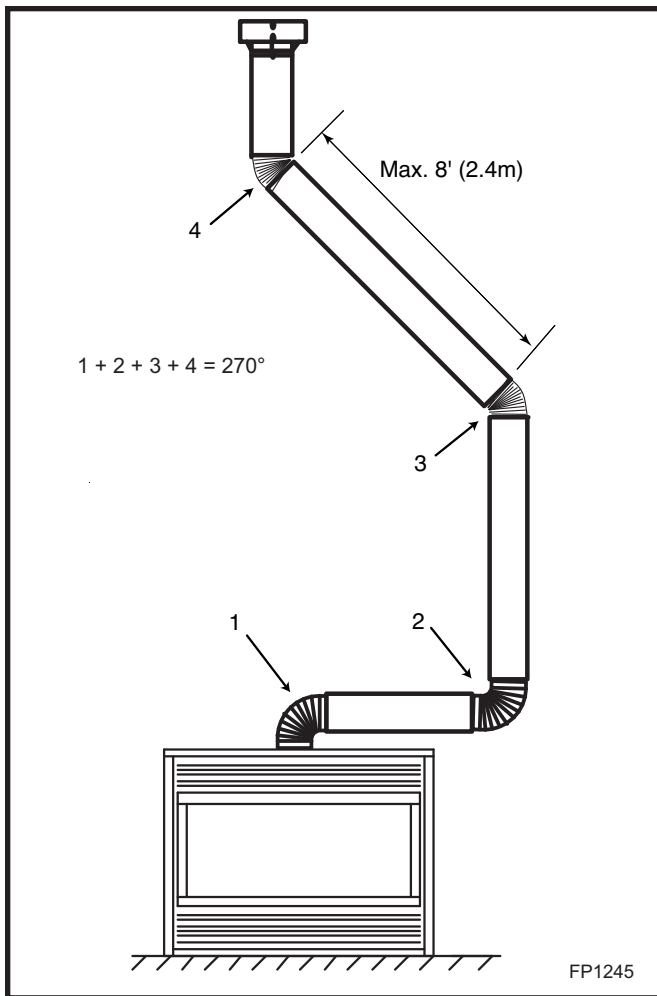

Fig. 56 Typical offset application.

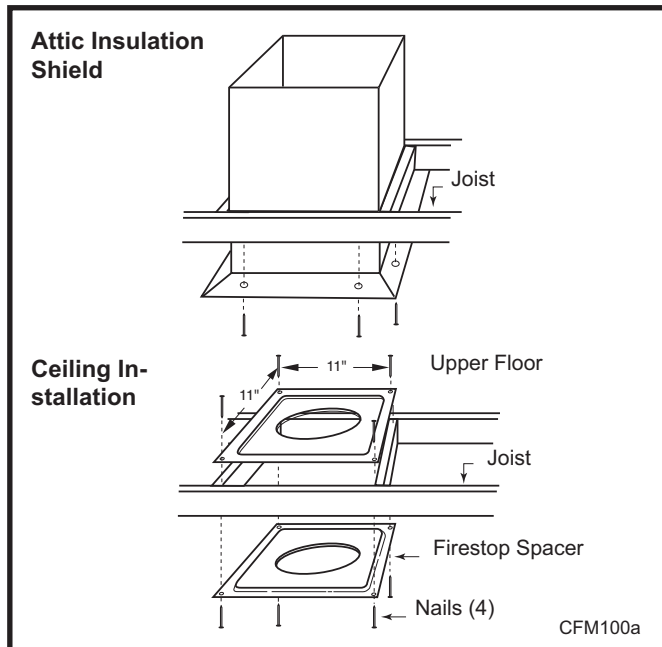

Fig. 57 Place firestop spacer(s) and secure.

8. Install appropriate pipe sections until the venting is above the flashing. (Fig. 58)
9. Install storm collar and seal around the pipe.
10. Add additional vent lengths for proper height. (Fig. 60)
11. Apply high temperature sealant to 4" and 7" collars.

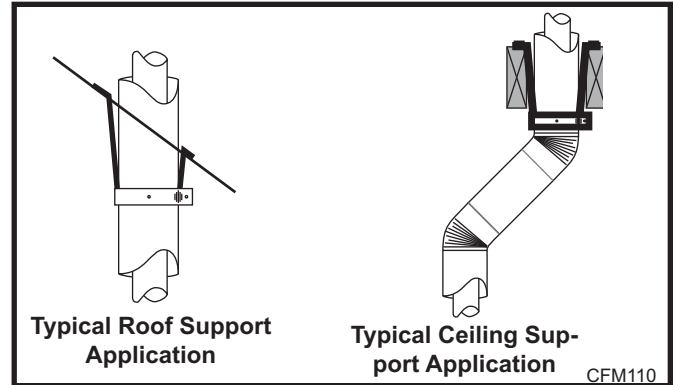

Fig. 58 Roof and ceiling supports.

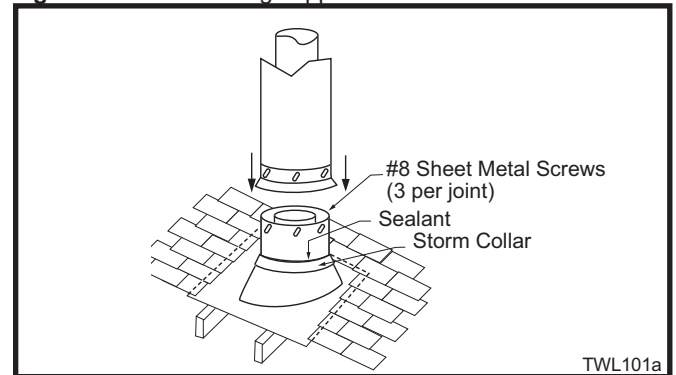

Fig. 59 Roof flashing.

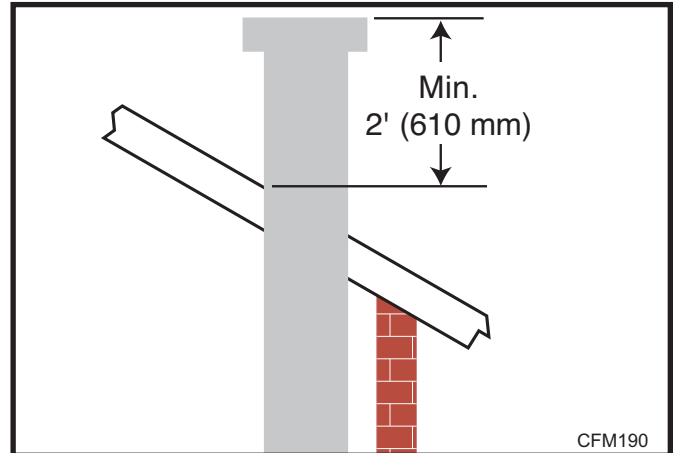
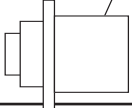
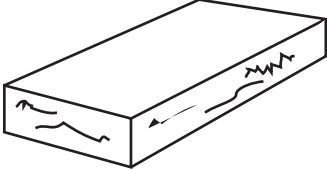
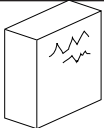
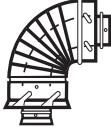

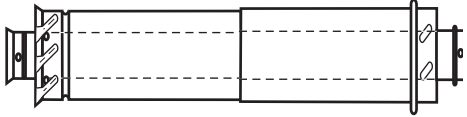
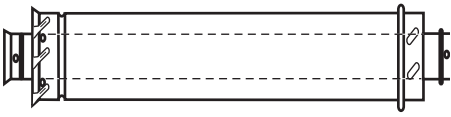
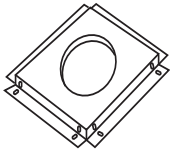
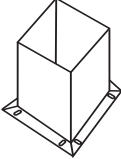



Fig. 60 Minimum termination to roof clearance.

! If there is a room above ceiling level, firestop spacer must be installed on both the bottom and the top side of the ceiling joists. If an attic is above ceiling level a 7DVAIS (Attic Insulation Shield) must be installed.

The enlarged ends of the vent section always face downward. (Fig. 59)

Venting Components	
	20010581 - Straight Out the Back Termination 10001953 - Through-the-Wall Termination (for other than straight out the back on rear vent)
	Starter Kit - Model 7TCRVT 1320: Straight thru Rear Vent for 13"-20" Vent Applications Model 7TCRVT: Straight thru Rear Vent for 7" - 13" Vent Application Model 7TCD45KT: Vent Kit for 45° Installation or 13" - 32" Rear Vent application Starter Kit* - Model 7TDVSKV - Vertical Venting for 7TDVSKV-A order 1/12 to 6/12 roof pitch for 7TDVSKV-B order 7/12 to 12/12 roof pitch for 7TDVSKV-F order flat roof Starter Kit for Below Grade Installation Model 7TDVSKS -Snorkel Kit (Twist Lock Pipe) Model 7FDVSKS -Snorkel Kit (Flex Vent Pipe)
*NOTE: Must order a 7TCDV90 elbow for rear vent to vertical application only.	
	Starter Pipe Model 7TDVP 20/8 - 24" Starter Pipe Bulk
	90° Elbow 7TCDV90 - For Rear to Vertical 7TDV90 - For Extended Run
	45° Elbow 7TDV45 for Rear Vent to Vertical Vent or Vertical/Horizontal Offsets
	Telescopic vent sections 7TDVP1117 -11" to 17" adjustable length 7TDVP3567 -35" to 67" adjustable length
	Pipe sections for vertical or horizontal venting Model 7TDVP8" - 4 per box Model 7TDVP12" - 4 per box Model 7TDVP24" - 4 per box Model 7TDVP36" Model 7TDVP48"
	Firestop Spacer Model 7DVFS
	Attic Insulation Shield Model 7DVAIS
	Vertical/Horizontal Combination Offset Support Model 7DVCS

Operating Instructions

Glass Information



Only glass approved by MHSC should be used on this fireplace.

- The use of any non-approved replacement glass will void all product warranties.
- Care must be taken to avoid breakage of the glass.
- **Do not operate appliance with glass front removed, cracked or broken.**
- **Replacement glass (complete with gasket) is available through your MHSC dealer and should only be installed by a licensed qualified service person.**

! WARNING



HOT GLASS WILL CAUSE BURNS.
DO NOT TOUCH GLASS UNTIL COOLED.
NEVER ALLOW CHILDREN TO TOUCH GLASS.

Louvre Removal

The top louvre panel is removed by lifting the panel vertically and pulling it away from the appliance. (Fig. 61) The lower access door is removed in the same manner.

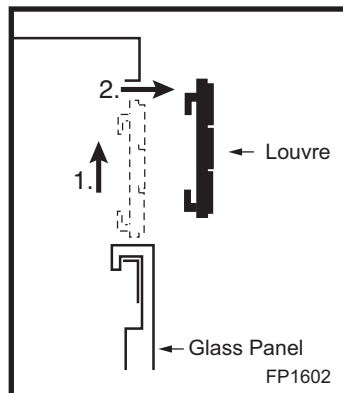

Fig. 61 Remove top louvre assembly.

Window Frame Assembly Removal

1. Turn the fireplace OFF (including the pilot)
2. If the unit has been operating allow time for the components to cool.
3. Remove the top louvre assembly.
4. Remove the lower louvre panel.
5. Release the two clamps securing the lower edge of the window frame assembly by pulling down on the handles. (Fig. 62)

6. Tilt the window frame assembly out slightly at the bottom, lift the window frame assembly up and away from the fireplace.
7. To replace the window frame assembly reverse the procedure.

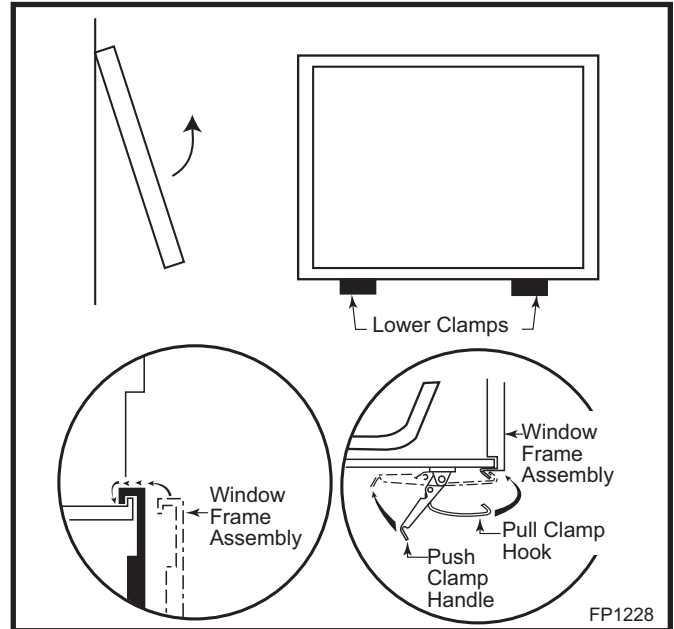

Fig. 62 Window frame assembly removal.

Glass Cleaning

It is necessary to periodically clean glass. During start-up condensation, which is normal, forms on the inside of the glass. This condensation causes lint, dust and other airborne particles to cling to glass surface. Also initial paint curing may deposit a slight film on the glass. It is therefore recommended the glass be cleaned two or three times with a non-ammonia based household cleaner and warm water (We recommend gas fireplace glass cleaner) within the first few weeks of operation.

After the initial cleaning process the glass should be cleaned two or three times during each operating season depending on the environment in the house.



Clean glass after first two weeks of operation.

Do not clean glass when hot.

Do not use abrasive cleaners.

Do not strike or slam the glass.

Logs

The 36CDVX logs are shipped in place. If a log is broken, refer to the replacement parts list for a replacement. Figure 63 shows where the logs are secured to the fireplace.

Figure 63

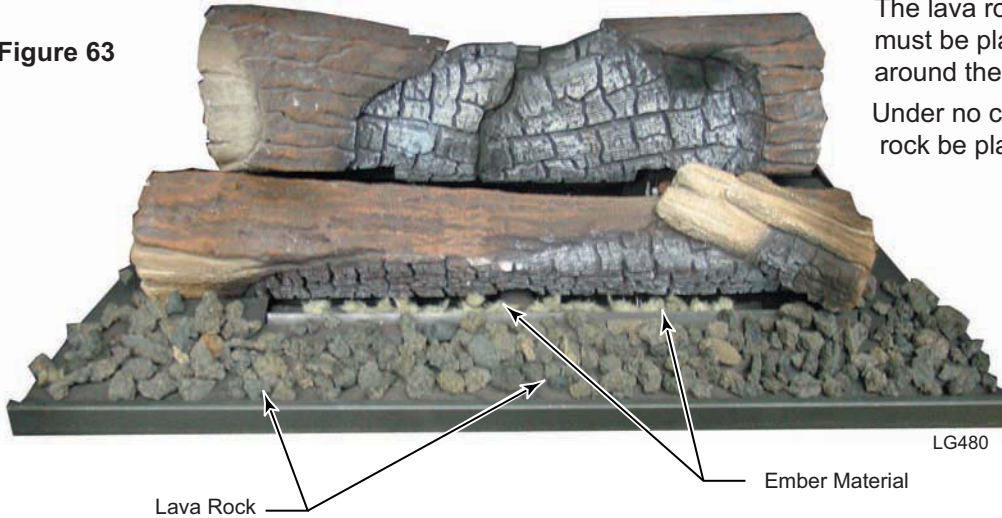

Ember Material and Lava Rock Placement

Separate the ember material into small pieces, roughly 1/2" in diameter and place on the front burner tube. Do NOT pack down, leave in fluffy, loose condition for most realistic ember effect. (Fig. 62)

The lava rock provided with this fireplace must be placed on the firebox base around the burner assembly. (Fig. 63)

Under no circumstances should this lava rock be placed on any part of the burner.

Flame & Temperature Adjustment

RN/RP & EN/EP Models

For units equipped with "HI/LO" valves the flame adjustment is accomplished by rotating the "HI/LO" adjustment knob located near the center of the gas control valve. (Figs. 64)

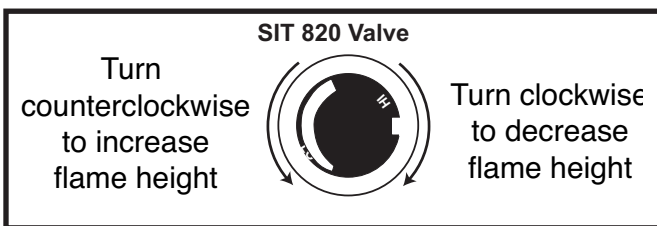

Fig. 64 Flame adjustment knob for SIT valve.

Flame Characteristics

It is important to periodically perform a visual check of the pilot and burner flames. Compare them to the illustrations. (Figs. 65 & 66)

If the flame patterns appear abnormal contact a qualified service provider for service and adjustment.

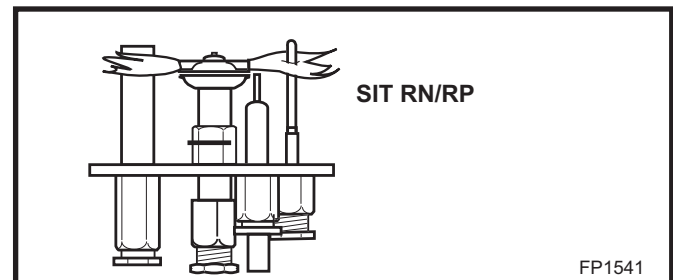
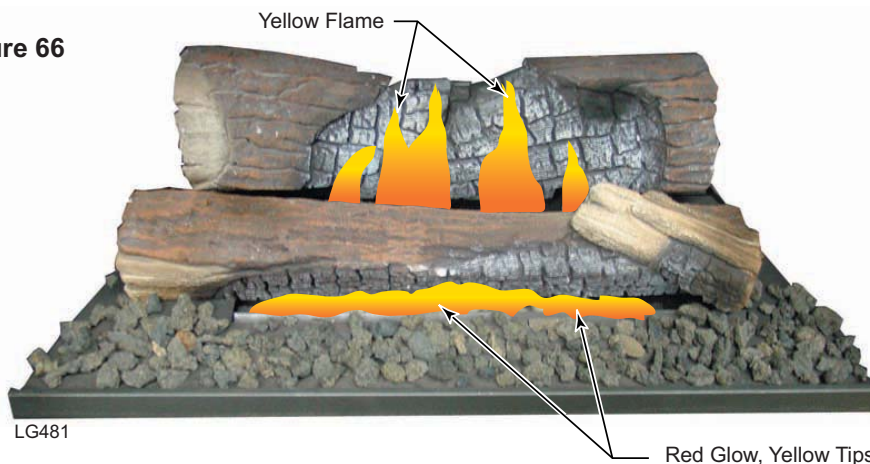

Fig. 65 Correct pilot flame appearance.

Figure 66



Lighting and Operating Instructions

FOR YOUR SAFETY READ BEFORE LIGHTING

WARNING: If you do not follow these instructions exactly, a fire or explosion may result causing property damage, personal injury or loss of life.

- A. This heater has a pilot which must be lit manually. When lighting the pilot follow these instructions exactly.
- B. BEFORE LIGHTING smell all around the heater area for gas. Be sure to smell next to the floor because some gas is heavier than air and will settle on the floor.

WHAT TO DO IF YOU SMELL GAS

- Do not try to light any fireplace
- Do not touch any electric switch
- Do not use any phone in your building
- Immediately call your gas supplier from a neighbor's phone.

Follow the gas supplier's instructions.

- If you cannot reach your gas supplier, call the Fire Department
- C. Use only your hand to push in or turn the gas control knob. Never use tools. If the knob will not push in or turn by hand, do not try to repair it, call a qualified service technician. Applying force or any attempted repair may result in a fire or explosion.
- D. Do not use this fireplace if any part has been under water. Immediately call a qualified service technician to inspect the heater and to replace any part of the control system and any gas control which has been under water.

Lighting Instructions

1. **STOP!** Read the safety information above.
2. Turn off all electrical power to the fireplace.
3. For MN/MP/TN/TP appliances ONLY, go on to Step 4. For RN/RP appliances turn the ON/OFF switch to "OFF" position or set thermostat to lowest level.
4. Open control access panel.
5. Push in gas control knob slightly and turn clockwise  to "OFF".

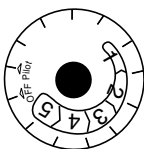

Euro SIT

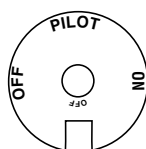

SIT NOVA



Honeywell

6. Wait five (5) minutes to clear out any gas. Then smell for gas, including near the floor. If you smell gas, STOP! Follow "B" in the safety information above. If you do not smell gas, go to the next step.
7. Remove glass door before lighting pilot. (See Glass Frame Removal section).
8. Visibly locate pilot by the main burner.
9. Turn knob on gas control counterclockwise  to "PILOT".

10. Push the control knob all the way in and hold. Immediately light the pilot by repeatedly depressing the piezo spark ignitor until a flame appears. Continue to hold the control knob in for about one (1) minute after the pilot is lit. Release knob and it will pop back up. Pilot should remain lit. If it goes out, repeat steps 5 through 8.

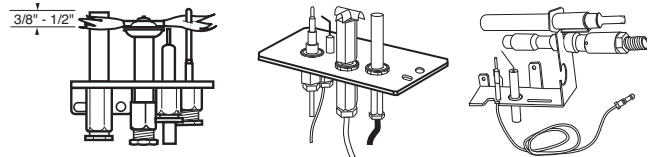

- If knob does not pop up when released, stop and immediately call your service technician or gas supplier.
- If after several tries, the pilot will not stay lit, turn the gas control knob to "OFF" and call your service technician or gas supplier.

11. Replace glass door.
12. Turn gas control knob to "ON" position.
13. For RN/RP appliances turn the ON/OFF switch to "ON" position or set thermostat to desired setting.
14. Turn on all electrical power to the fireplace.

To Turn Off Gas to Fireplace

1. Turn the ON/OFF switch to Off position or set the thermostat to lowest setting.
2. Turn off all electric power to the fireplace if service is to be performed.
3. Open control access panel.
4. Push in gas control knob slightly and turn clockwise  to "OFF". Do not force.
5. Close control access panel.

Lighting and Operating Instructions

For Fireplaces equipped with SIT822 Gas Valve (EN or EP)

Warning: If you do not follow these instructions exactly, a fire or explosion may result causing property damage, personal injury and loss of life.

FOR YOUR SAFETY READ THE FOLLOWING WARNINGS BEFORE LIGHTING THE APPLIANCE

A. This fireplace is equipped with an ignition device which automatically lights the pilot. **DO NOT** try to light the pilot by hand.

B. **BEFORE OPERATING**, smell all around the appliance area for gas. Be sure to smell next to the floor because some gas is heavier than the air and will settle on the floor.

What to do if you smell gas

- Do not try to light any appliance
- Do not operate any electrical switch.
- Do not use any phone in your building.
- Immediately call your gas supplier from a neighbor's phone.

Follow the gas suppliers instructions.

- If you cannot contact your gas supplier call the Fire Department

C. Use only your hand to push in or turn the gas control knob. Never use tools. If the knob will not push in or turn by hand do not try to repair it, call a qualified service technician. Force or attempting repair may result in a fire or explosion.

D. Do not use this appliance if any part has been under water. Immediately call a qualified service technician to inspect the appliance and replace any part of the control system and any gas control that has been under water.

Lighting Instructions

1. **STOP!** Read the safety information above before continuing.
2. Turn off all electrical power to the appliance.
3. This appliance is equipped with an ignition device which automatically lights the pilot. **DO NOT** try to light the pilot by hand.
4. Access the gas control by lowering the lower access door (louvre assembly).

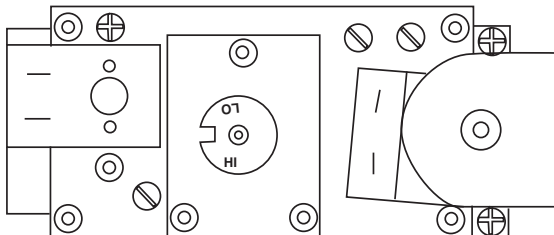

5. Turn the remote switch, if used, OFF. Turn the wireless remote, if used, OFF.
6. Wait five (5) minutes to clear out any gas. Then smell for gas, including near the floor. If you smell gas STOP. Follow instructions B in the safety warnings above. If you do not smell gas go onto the next step.
7. Close the access door.
8. Turn ON all electrical power to the appliance.
9. Turn remote switch or wireless remote to "ON".
10. If the appliance will not operate, follow the instructions TURNING OFF THE GAS TO THE APPLIANCE and call your service technician or gas supplier.

Turning Off the Gas to the Appliance

1. Turn the remote switch to the "OFF" position.
2. Turn OFF all electrical power to the fireplace if service is required.
3. Open the lower access panel.
4. Turn the shut-off valve on the flexible gas line to the "OFF" position.

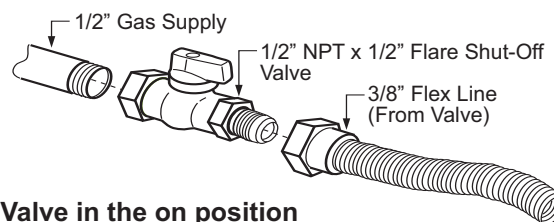

Valve in the on position

Troubleshooting the Gas Control System

SIT NOVA 820 MILLIVOLT VALVE

NOTE: Before trouble shooting the gas control system, be sure external gas shut off is in the "On" position.

WARNING: BEFORE DOING ANY GAS CONTROL SERVICE WORK, REMOVE GLASS FRONT.

SYMPTOM	POSSIBLE CAUSES	CORRECTIVE ACTION
1. Spark ignitor will not light	A. Defective or misaligned electrode at pilot.	Using a match, light pilot. If pilot lights, turn off pilot and push the red button again. If pilot will not light - check gap at electrode and pilot-should be 1/8" to have a strong spark.
	B. Defective ignitor (Push Button)	Push Piezo Ignitor Button. Check for spark at electrode and pilot. If no spark to pilot, and electrode wire is properly connected, replace ignitor.
2. Pilot will not stay lit after carefully following lighting instructions.	A. Defective pilot generator (thermocouple), remote wall switch.	Check pilot flame. Must impinge on thermo couple/thermopile. Note: this pilot burner assembly utilizes both-a thermocouple and a thermopile. The thermocouple operates the main valve operation (On and Off). Clean and or adjust pilot for maximum flame impingement on thermopile and thermocouple.
	B. Defective automatic valve	Turn valve knob to "Pilot". Maintain flow to pilot; millivolt meter should read greater than 10 mV. If the reading is okay and the pilot does not stay on, replace the gas valve. Note: An interrupter block (not supplied) must be used to conduct this test.
3. Pilot burning, no gas to main burner	A. Wall switch or wires defective	Check wall switch and wires for proper connections. Jumper wire across terminals at wall switch, if burner comes on, replace defective wall switch. If okay, jumper wires across wall switch wires at valve, if burner comes on, wires are faulty or connections are bad.
	B. Thermopile may not be generating sufficient millivoltage.	<ol style="list-style-type: none"> 1. Be sure wire connections from thermopile at gas valve terminals are tight and thermopile is fully inserted into pilot bracket. 2. One of the wall switch wires may be grounded. Remove wall switch wires from valve terminals if pilot now stays lit, trace wall switch wiring for ground. May be grounded to fireplace or gas supply. 3. Check thermopile with millivolt meter. Take reading at thermopile terminals of gas valve. Should read 250-300 millivolts (minimum 150) while holding valve knob depressed in pilot position and wall switch "Off". Replace faulty thermopile if reading is below specified minimum.
	C. Plugged burner orifice.	Check burner orifices for debris and remove.
	D. Defective automatic valve operator.	Turn valve knob to "On", place wall switch to "On" millivolt meter should read greater than 100 mV. If the reading is okay and the burner does not come on, replace the gas valve.
4. Frequent pilot outage problem.	A. Pilot flame may be too low or blowing (high) causing the pilot safety to drop out.	Clean and/or adjust pilot flame for maximum flame impingement on thermopile and thermocouple.
	B. Possible blockage of the vent terminal.	Check the vent terminal for blockage (recycling the flue gases)

Fuel Conversion Instructions



The conversion of this appliance from one gas to another must be carried out by an authorized service provider.



The procedure for converting from one gas to another is the same regardless of the initial gas used. The only variation is in the orifice sizes and component part numbers. Your authorized service provider will ensure the correct parts are used.

1. Disconnect power to the unit and shut off the gas supply.
2. Remove window frame assembly.
3. Remove the lava rock and ember material. (Fig. 67)

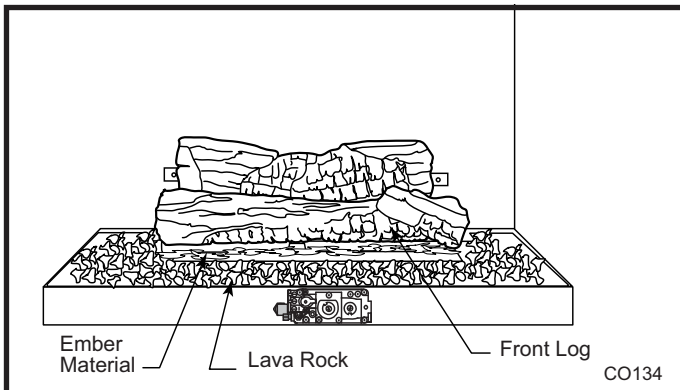

Fig. 67 Remove lava rock and ember material.

4. Push the log support towards the back of the fireplace and lift out the front log mounting assembly. (Fig. 68)
5. Remove the two (2) screws securing the rear log to the back of the firebox. Remove the three (3) screws securing the rear log support to the back of the firebox. (Fig. 69)

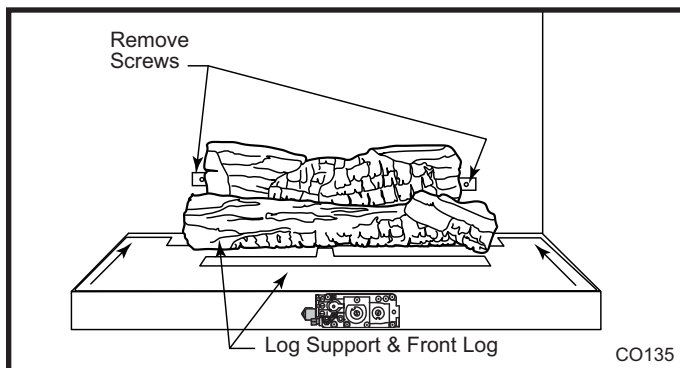

Fig. 68 Remove rear log and log support and front log.

6. Remove the two (2) screws securing the burner tube to the burner pan. (Fig. 69)
7. Remove the orifice from the brass elbow. Use a 9/16" open end wrench to hold the elbow while using the 1/2" wrench to remove the orifice. (Fig. 70)

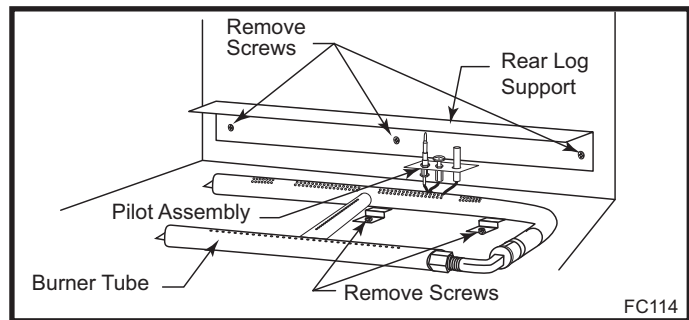

Fig. 69 Remove burner tube and rear log support.

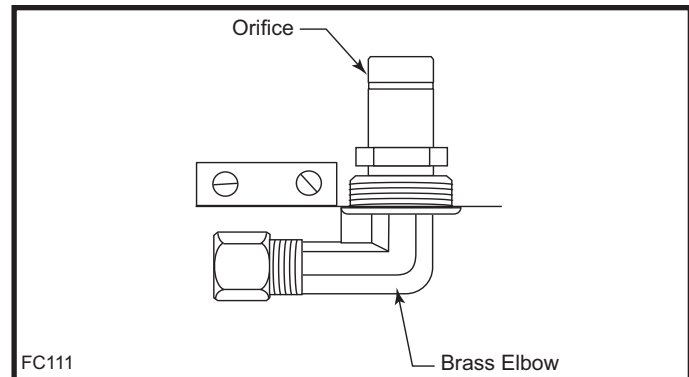

Fig. 70 Remove orifice from brass elbow.

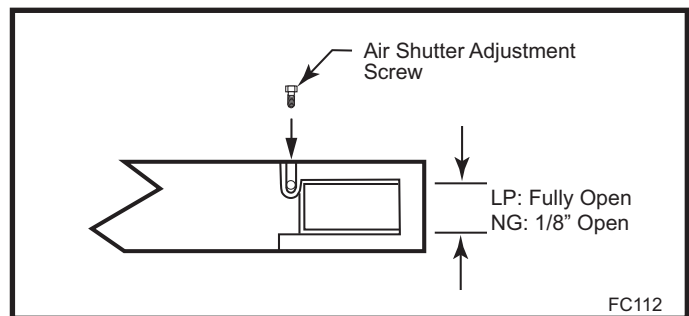

Fig. 71 Adjust air shutter.

8. Install the new conversion orifice.
9. Loosen the adjusting screw that holds the air shutter to the burner tube. Adjust air shutter to:
LP - fully open; NG - 1/8" open. (Fig. 71)
10. Install the burner tube and secure with the two (2) screws removed earlier.
11. Burner orifice installation complete.

Pilot Conversion

NOTE: It is not necessary to remove the pilot tube for conversion.

1. Remove pilot hood by lifting up. (Fig. 72)
2. Remove pilot orifice with the appropriate size Allen wrench. (Fig. 73)
3. Install conversion pilot orifice.
4. Reinstall pilot hood. Be sure to align pilot hood with index tab.

Pilot conversion installation is complete.

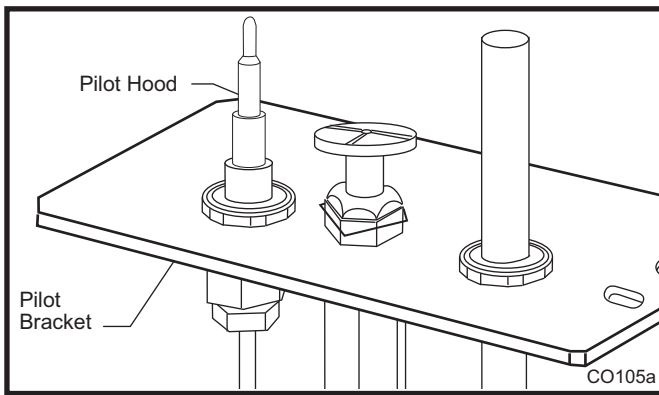

Fig. 72 Remove pilot hood.

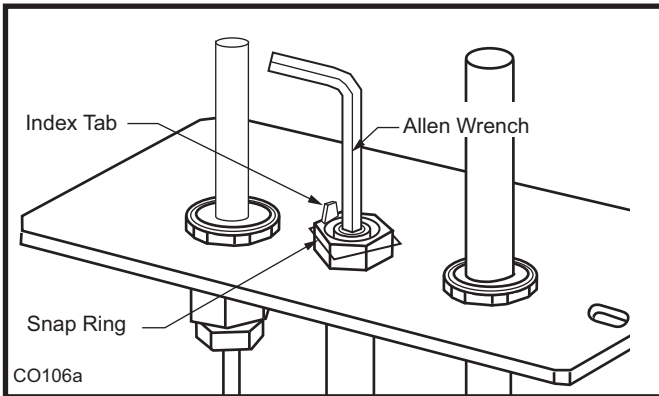

Fig. 73 Remove pilot orifice and replace with conversion orifice.

Valve Regulator Conversion

SIT 820 NOVA Gas Control Valve (Fig. 74)

1. Using a Torx T20 or slotted screwdriver, remove and save the three pressure regulator mounting screws (A), pressure regulator tower (B) and diaphragm (C).
2. Ensure the rubber gasket (D) is properly positioned and install the new HI/LO pressure regulator to the valve using the new screws (E) supplied with the kit. Tighten screws securely. (Reference torque - 25 in.LB)

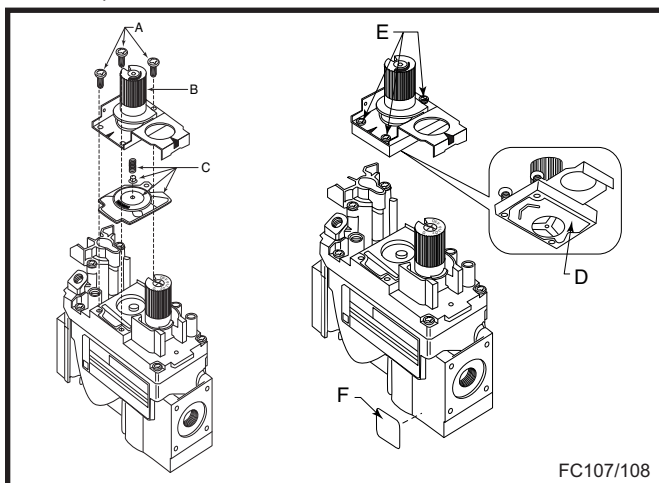

Fig. 74 Nova SIT820 Gas Valve.

3. Install the enclosed identification label (F) to the valve body where it can be easily seen.

Testing for Leaks

1. Apply gas to the system and light the pilot.
2. With a soapy solution check for leaks around the pilot assembly where the tube enters the pilot assembly. Tighten fitting if necessary.
3. Light the main burner and check for leaks around the new pressure regulator assembly. Tighten screws if necessary.
4. With the main burner "ON" rotate the Hi/Lo knob and verify the proper burner operation.

Pilot Flame Adjustment

Typically, the top 3/8" or 1/2" of the thermopile should be engulfed in the pilot flame. (Fig. 75)

To adjust pilot burner:

1. Remove pilot adjustment cap located on valve.
2. Adjust pilot screw to provide properly sized flame.
3. Replace pilot adjustment cap.

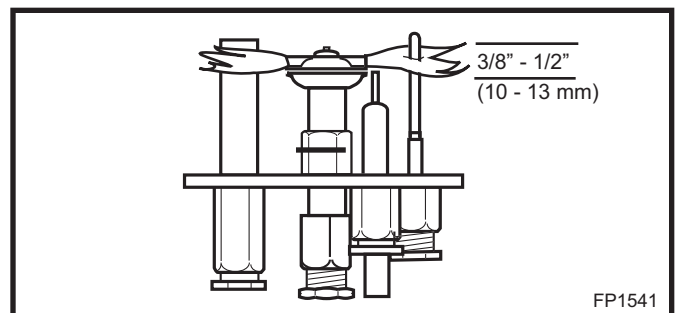

Fig. 75 Correct pilot flame appearance.

Reassembly

1. Turn the fireplace off.
2. Reverse Steps 3-6 in 'Burner Orifice Conversion' to reassemble fireplace.
3. Reinstall glass door.
4. Conversion of the fireplace is complete.

Maintenance

Burner and Burner Compartment

It is important to keep the burner and the burner compartment clean. At least once per year the logs and lava rock/ember material should be removed and the burner compartment vacuumed and wiped out. Remove and refit the logs as per the instructions in this manual.



Always handle the logs with care as they are fragile and may also be hot if the fireplace has been in use.

FK12 Fan Assembly

The fan unit requires periodic cleaning. At least once per month in the operating season open the lower louver panels and wipe or vacuum the area around the fan to remove any build up of dust or lint.

Cleaning the Standing Pilot Control System

The burner and control system consist of:

- burner
- gas orifice
- pilot assembly
- thermopile
- millivolt gas valve

Most of these components may require only an occasional checkup and cleaning and some may require adjustment. **If repair is necessary, it should be performed by a qualified technician.**

1. Turn off pilot light at gas valve.
2. Allow fireplace to cool if it has been operating.
3. Remove window frame assembly. (Refer to Window Frame Assembly Removal section.)
4. Vacuum burner compartment especially around orifice primary air openings.
5. Visually inspect pilot. Brush or blow away any dust or lint accumulation.
6. Ignite pilot - Refer to Lighting Instructions.
7. Reinstall window frame assembly.

To obtain proper operation, it is imperative that the pilot and burner's flame characteristics are steady, not lifting or floating.

Typically, the top 3/8" to 1/2" of the thermopile should be engulfed in the pilot flame. (Refer to Page 35, Figure 75)

To adjust pilot burner: (by qualified service technician)

1. Remove pilot adjustment cap
2. Adjust pilot screw to provide properly sized flame.
3. Replace pilot adjustment cap.

The primary air shutter is set at factory and should only be adjusted, if necessary, by a qualified service technician.

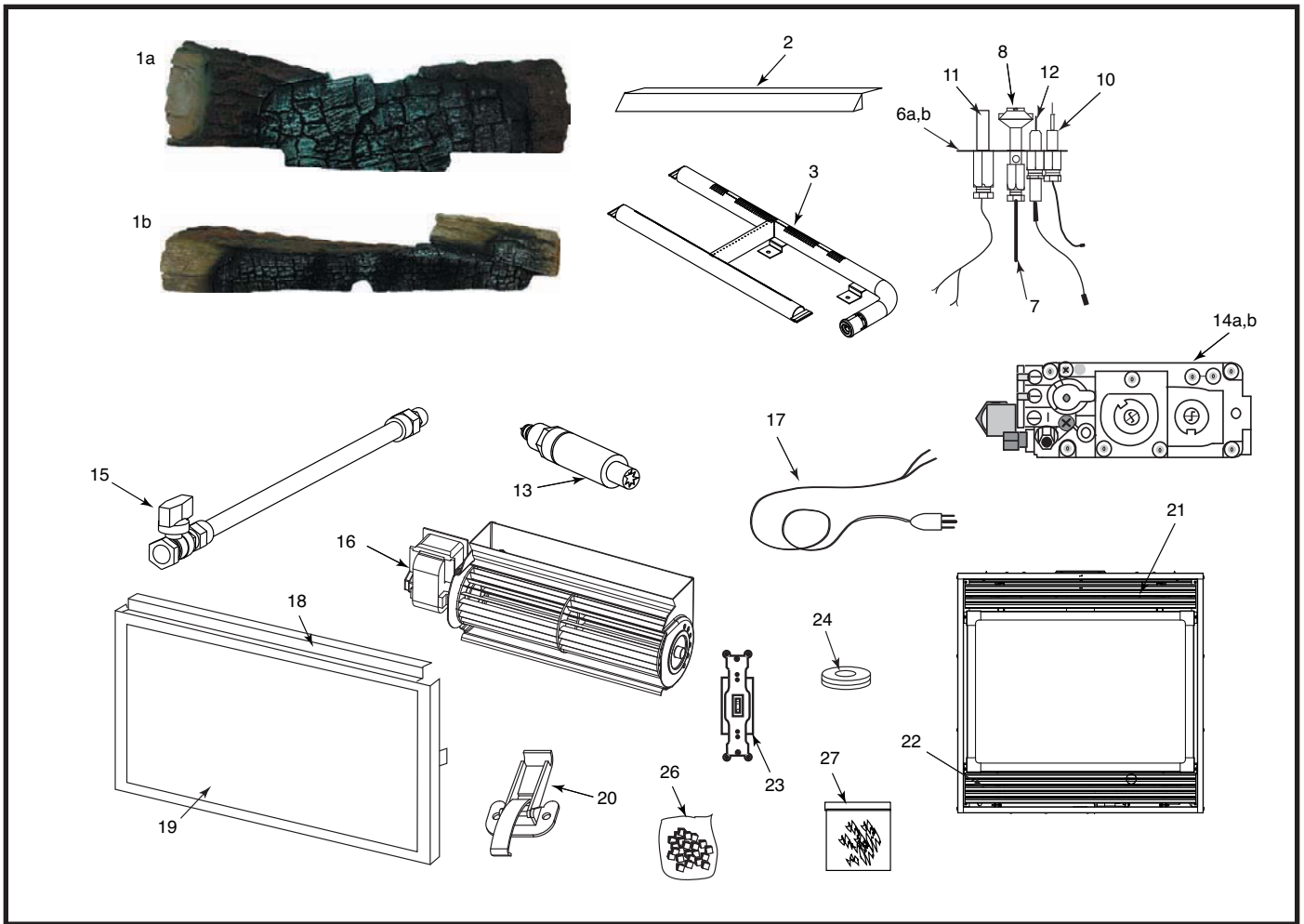

MHSC reserves the right to make changes in design, materials, specifications, prices and discontinue colors and products at any time, without notice.

CDVX

Units: GFRL1J1, GFTN1J0

Ref.	Description	36CDVX
1a.	Log Rear Assy	20012251
1b.	Log Middle Assy	20012108
2.	Hood	20010312
3.	Burner Tube	20010333
4.	Orifice Burner - Natural (not shown)	72386
5a.	Orifice Pilot - Natural (not shown)	10002268
5b.	Orifice Pilot - Propane (not shown)	10002269
6a.	Pilot Assy SIT - RN	20010203
6b.	Pilot Assy SIT - RP	20010202
7.	Pilot Tubing w/Fittings SIT	10001296
8.	Pilot Hood	10002385
9.	Manifold Tubing (not shown)	20010162
10.	Thermocouple - RN/RP	53373
11.	Thermopile - RN/RP	51827
12.	Electrode Ignitor w/Cable RN/RP	10001297
13.	Ignitor Piezo SIT 820 Valve	52464
14a.	Valve SIT 820 - RN	52677
14b.	Valve SIT 820 - RP	52678

CDVX (continued)

Ref.	Description	36CDVX
15.	Flexible Gas Line w/ON/Off Shut-Off Valve	20002500
16.	Fan Assy (FK12 Option)	ZA1110
17.	Electrical Cord (6 ft.)	51865
18.	Door Assy	20010207
19.	Frame Window	20010320
20.	Clamp Frame Window	10000949
21.	Top Louvre Assy	20010179
22.	Bottom Louvre Assy	20010179
23.	ON/OFF Switch	51842
24.	Grommet	20010348
25.	Wire/Bushing Assy (not shown)	20010346
26.	Lava Rock	20000376
27.	Ember Material	51915

Fuel Conversion Kits

36CDVX NG to LP Kit # 20010507
 36CDVX LP to NG Kit # 20014425

Optional Accessories Available

Fan Kits

FK12

This auxiliary fan system increases the efficiency of the circulation of the heating air.

The FK12 Fan Assembly is a fixed speed fan system and does not allow for variable speed control.

Specifications

115 Volts / 60 Hz / 56 Watts.

Maintenance

The fan itself does not require regular maintenance, however periodic cleaning of the fan and the surrounding area is required.

Check the area under the control door (lower louvre assembly) and in front of the fan and wipe or vacuum this area at least once a month during the operating season.

Installation

The fan assembly is supplied fully wired eliminating the need for a licensed electrician to carry out the installation.

1. Remove the lower Louvre assembly. Move the fan & bracket assembly around the gas valve and lines to locate the unit against the back wall of the appliance, resting on the base.
2. With the protective cover removed from the self-adhesive 'Velcro' strips apply mild pressure to the fan & bracket unit to secure the strips to the metal panels. No further securing is required.
3. Power to the fan can be supplied by plugging the supplied lead into a conveniently located wall socket or by using the receptacle in the bottom of the unit.

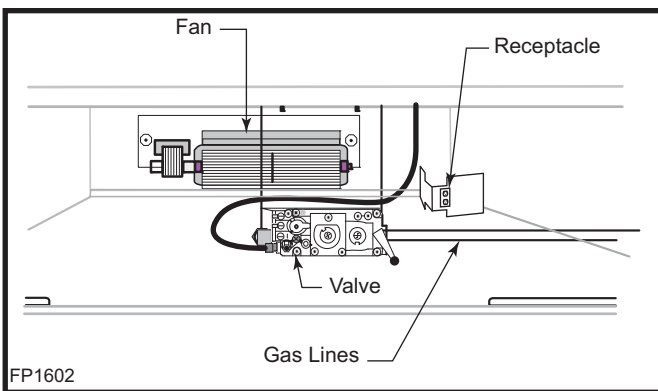

Fig. 76 FK12 fan placement.

Wiring Instructions



The fireplace, when installed, must be electrically connected and grounded in accordance with local codes or, in the absence of local codes, with the current CSA C22.1 Canadian Electric Code.



For USA installations follow the local codes and the national electrical code ANSI/NFPA No. 70.



Should this fan require servicing or repair the power supply must be disconnected.



Any electrical rewiring of this fan must be done by a licensed electrician.

Remote Controls

Optional remote control units are available to control different functions of the appliances.

Model	Function/s Controlled
RC1	ON/OFF
RC2	ON/OFF and Temperature
IMTFK	Wall mounted thermostat control (must be used in bedroom installations)

Optional Trim

The Perimeter trim is designed to enhance the look of the fireplace.

Model	Description
36CDVTK	Perimeter Trim Black

LIMITED LIFETIME WARRANTY

Lifetime Warranty

The following components are warranted for life to the original owner, subject to proof of purchase: Firebox, Combustion Chamber, Heat Exchanger, Grate and Stainless Steel Burners.

Five Year Warranty

The following components are warranted for five (5) years to the original owner, subject to proof of purchase: Ceramic Fiber Logs.

Basic Warranty

MHSC warrants the components and materials in your gas appliance to be free from manufacturing and material defects for a period of two (2) years from date of installation. After installation, if any of the components manufactured by MHSC in the appliance are found to be defective in materials or workmanship, MHSC will, at its option, replace or repair the defective components at no charge to the original owner. MHSC will also pay for reasonable labor costs incurred in replacing or repairing such components for a period of two (2) years from date of installation. Any products presented for warranty repair must be accompanied by a dated proof of purchase.

This Limited Lifetime Warranty will be void if the appliance is not installed by a qualified installer in accordance with the installation instructions. The Limited Lifetime Warranty will also be void if the appliance is not operated and maintained according to the operating instructions supplied with the appliance, and does not extend to (1) firebox/burner assembly damage by accident, neglect, misuse, abuse, alterations, negligence of others, including the installation thereof by unqualified installer, (2) the costs of removal, reinstallation or transportation of defective parts on the appliance, or (3) incidental or consequential damage. All service work must be performed by an authorized service representative.

This warranty is expressly in lieu of other warranties, express or implied, including the warranty of merchantability of fitness for purpose and of all other obligations or liabilities. MHSC does not assume for it any other obligations or liabilities in connection with sale or use of the appliance. In states that do not allow limitations on how long an implied warranty lasts, or do not allow exclusion of indirect damage, those limitations of exclusions may not apply to you. You may also have additional rights not covered in the Limited Lifetime Warranty.

MHSC reserves the right to investigate any and all claims against the Limited Lifetime Warranty and decide upon method of settlement.

For information about this warranty, contact:

Technical Services
MHSC
149 Cleveland Drive
Paris, KY 40361

Canada

ENERGUIDE

**Look for the EnerGuide
Gas Fireplace Energy
Efficiency Rating in this brochure**

Based on CSA P.4.1-02

Efficiency Ratings				
Model	EnerGuide Ratings Fireplace Efficiency (%)	Steady State (%)		D.O.E. (AFUE%)
		Fan-OFF	Fan-ON	
36CDVXRRN	66.9	76	76.5	63
36CDVXRRP	66.9	77	78	63
36CDVXTRN	57	76	76.5	63
36CDVXTRP	57	77	78	63

**NATIONAL
FIREPLACE
INSTITUTE**



CERTIFIED
www.nficertified.org

We recommend that our gas hearth products be installed and serviced by professionals who are certified in the U.S. by the National Fireplace Institute® (NFI) as NFI Gas Specialists.