

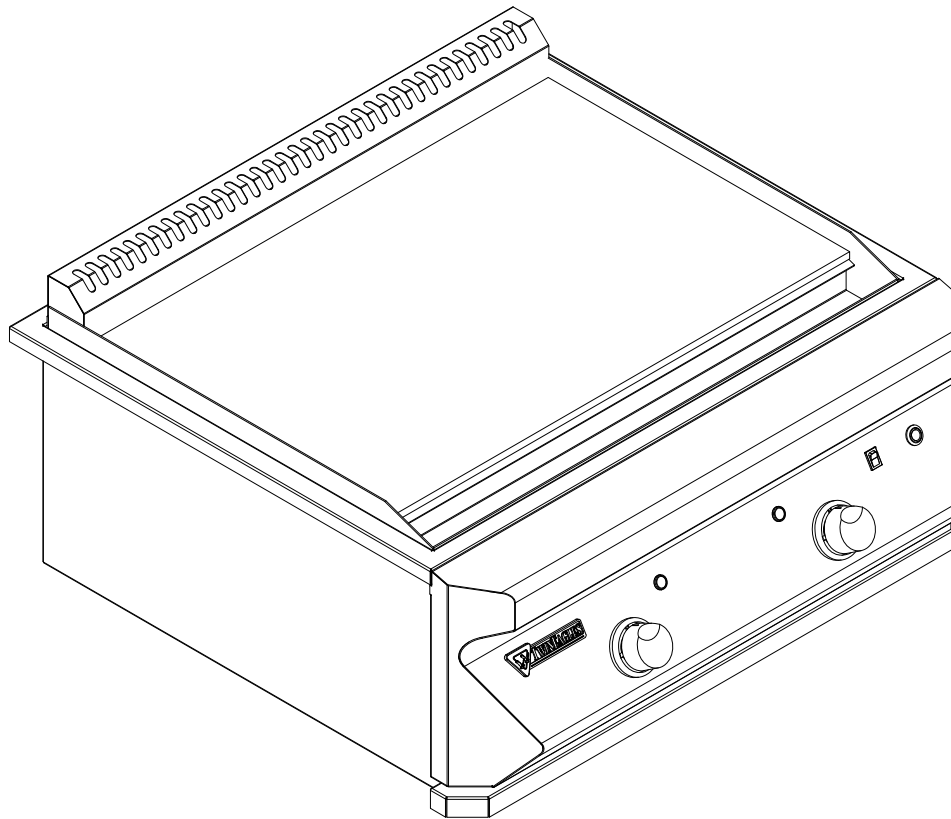

# TEPPANYAKI GRIDDLE USE AND CARE MANUAL



*A special message...*

Congratulations on your purchase of TWIN EAGLES Teppanyaki Griddle. In addition to its Unique Style, Superb Performance and High Quality, this appliance is built with pride in the U.S.A. Twin Eagles is committed to making outdoor cooking products you'll be proud to own for years.

This manual gives you easy to follow instructions for installing, operating and maintaining your TWIN EAGLES Teppanyaki Griddle. We recommend reading this manual carefully before your first use to insure safety, proper care and operation.

Thank you and welcome!

TWIN EAGLES

---

FOR YOUR RECORDS

Please retain a copy of your sales receipt for warranty claims.

Please record the following information and refer to them when contacting the company or an authorized service agent. This information is found on the rating/serial plate, located on the inside wall of the left hand side panel. You can visually access the rating/serial plate by looking underneath the griddle when facing the front of the appliance.

Model #: \_\_\_\_\_

Serial #: \_\_\_\_\_

Date of Purchase: \_\_\_\_\_

Place of Purchase: \_\_\_\_\_

Type of Gas:     NG         LP



## IMPORTANT SAFETY INFORMATION – TWIN EAGLES TEPPANYAKI GRIDDLE



### Warning

Read this manual carefully and completely before using your Teppanyaki Griddle to ensure proper operation, installation, servicing and to reduce the risk of fire, burn hazard and/ or other injury.

Improper installation, adjustment alteration, service or maintenance can cause property damage, injury or death.

Do not operate this appliance without having carefully read this manual. In the event of power failure, do not attempt to operate this appliance.

All gas installations, electrical connections and gas conversions must be performed by a qualified technician or authorized service agent.

This appliance is not intended for commercial use.

### FOR YOUR SAFETY

#### If you smell gas:

1. **Shut off gas to the appliance.**
2. **Extinguish any open flame.**
3. **If odor continues, immediately call your gas supplier or your fire department.**

### FOR YOUR SAFETY

1. **Do not store or use gasoline or other flammable vapors and liquids in the vicinity of this or any other appliance.**
2. **An LP cylinder not connected for use shall not be stored in the vicinity of this or any other appliance.**

## GENERAL SAFETY REQUIREMENTS:

1. The installation of this outdoor cooking gas appliance, **Teppanyaki Griddle**, must conform with local codes or, in the absence of local codes, either the *National Fuel Gas Code, ANZI Z223.1/NFPA 54, or CAN/CGA-B149.1, Natural Gas Installation Code or CAN/CGA-B149.2, Propane Installation Code*.
2. This outdoor cooking gas appliance is not intended to be installed in or on recreational vehicles and /or boats.
3. This outdoor cooking gas appliance is intended for use outdoors and shall not be used in a building, garage or any other enclosed area.
4. **Minimum clearance of 12 inches from the back and sides of the griddle to adjacent combustible construction must be maintained. This outdoor cooking gas appliance shall not be located under overhead-unprotected combustible construction.**
5. The utilization of an external electrical source requires that when installed, this outdoor cooking gas appliance must be electrically grounded in accordance with the local codes or, in the absence of local codes, with the National Electrical Code, ANSI/NFPA 70, or the Canadian Electrical Code, CSA C22.1. Keep any electrical supply cord and the fuel supply hose away from any heated surfaces.
6. Keep your Teppanyaki Griddle in an area clear and free from combustible materials, gasoline and other flammable vapors and liquids.
7. DO NOT obstruct the flow of combustion and ventilation air to this appliance. Keep the ventilation openings of the cylinder enclosure free and clear from debris.
8. Check all gas connections for leaks with soapy water solution and brush. Never use an open flame. (Reference page 8 for leak test procedure).
9. Check flexible hoses for cuts and wear that may affect the safety before each use.
10. The pressure regulator and hose assembly supplied with the Twin Eagles Teppanyaki Griddle must be used. Replacement pressure regulators and hose assemblies must be those specified by Twin Eagles.
11. CALIFORNIA PROPOSITION 65-WARNING: The burning of gas cooking fuel generates some by-products which are on the list of substances known by the State of California to cause cancer or reproductive harm. California law requires businesses to warn customers of potential exposure to such substances. To minimize exposure to these substances always operate this unit according to the use and care manual, ensuring you provide good ventilation when cooking with gas.

In Massachusetts: All gas products must be installed using a "Massachusetts" licensed plumber or gasfitter. A "T" handle type manual gas valve must be installed in the gas supply line to this appliance. This applies to permanently installed natural gas and propane installations. This does not apply to propane portable installations using a 20 pound tank.

## TABLE OF CONTENTS – TWIN EAGLES TEPPANYAKI GRIDDLE

<b>GETTING STARTED</b>	
○ ELECTRICAL SPECIFICATIONS.....	1
○ LIQUID PROPANE GAS REQUIREMENTS.....	1
○ NATURAL GAS REQUIREMENTS.....	1
○ SHIPMENT.....	1
○ UNPACKING.....	1
<b>DETERMINE LOCATION.....</b>	<b>2</b>
○ NON-COMBUSTIBLE MATERIAL ENCLOSURE.....	2
○ CUT-OUT DIMENSIONS FOR BUILT-IN.....	3
<b>GAS REQUIREMENTS .....</b>	<b>4</b>
○ NATURAL GAS HOOK-UP.....	5
○ LP GAS HOSE.....	6
○ LP GAS CYLINDER.....	6
○ BOTTLED LP GAS HOOK-UP.....	7
○ GAS LEAK TEST.....	8
<b>OPERATING INSTRUCTIONS .....</b>	<b>9</b>
<b>CLEANING &amp; MAINTENANCE</b>	
○ GRIDDLE PLATE.....	9
○ GREASE TRAY.....	10
○ FLUE COVER ASSEMBLY .....	10
○ SPIDER AND INSECT WARNING.....	10
<b>EXPLODED VIEW DRAWING.....</b>	<b>11</b>
<b>REPLACEMENT PARTS LIST.....</b>	<b>12</b>
<b>WARRANTY.....</b>	<b>13</b>
<b>HOW TO OBTAIN SERVICE.....</b>	<b>13</b>
<b>WARRANTY REGISTRATION .....</b>	<b>14</b>

## GETTING STARTED – TWIN EAGLES TEPPANYAKI GRIDDLE

Safe and satisfactory operation of the Teppanyaki Griddle depends upon its proper installation. The installation, adjustments and service of the Griddle must be performed only by a qualified installer and service technician. Proper location and proper use is essential to insure safe and continued trouble-free operation. Any alterations made to the appliance will void the product's warranty.

Before installing, check the rating/serial plate of the Teppanyaki Griddle. Use only the electrical power supply and type of gas supply (natural or propane) as specified on the rating/serial plate. This information is found on the serial plate, located on the inside wall of the left hand side panel.

### **Electrical Specification**

The appliance should only be taken apart by a qualified technician, or electrical shock may occur. It is rated at 120V, 60Hz, 900W and 8A.

**Propane or LP:** If your griddle is factory built for L.P., the regulator supplied is set for 11" water column and is for use with L.P. gas only. The factory-supplied regulator and hose must be used with a 20 lb. L.P. cylinder. Do not use any replacement regulator other than that specified by Twin Eagles

**Natural Gas or NG:** If the griddle is factory built for natural gas, the regulator supplied is set for 4" water column. Do not use any replacement regulator other than that specified by Twin Eagles

**SHIPMENT:** This Teppanyaki griddle was inspected before leaving the factory. The shipping carrier assumes full responsibility for safe delivery of the appliance. Check for possible shipping damage immediately after unpacking. If the griddle is found to be damaged, save the packaging material and contact the shipping carrier immediately.

**UNPACKING:** Remove all packaging materials, labels and protective plastic film. DO NOT LEAVE UNIT UNDER THE SUN WITH PROTECTIVE PLASTIC FILM ON FOR A LONG PERIOD OF TIME AS IT WILL BECOME DIFFICULT TO REMOVE THE FILM.



## **Determine Location**

When determining a suitable location take into account concerns such as exposure to wind, proximity to traffic paths and keeping any gas supply lines as short as possible. Locate the griddle only in a well ventilated area. For free standing configurations allow 12” from the sides and rear to combustible construction while in operation.

The Teppanyaki Griddle must be located **outdoors only**. As with any gas appliance, harmful carbon monoxide is produced during the combustion process that should not be allowed to accumulate in a confined space. Also, since hot air rises above the Teppanyaki Griddle while in operation, covered locations should be avoided. Do not locate the Teppanyaki Griddle where an overhang or awning may cover it.

*The appliance is design-certified for use outdoors only and is not intended to be installed in or on recreational vehicles and/or boats. This appliance must be on a level, stable surface in an area clear of combustible material. An asphalt surface may not be acceptable for this purpose.*

## **NON-COMBUSTIBLE ENCLOSURE**

*The Teppanyaki Griddle must be installed in a **NON-COMBUSTIBLE ENCLOSURE ONLY**. The determination of whether a location is combustible or non-combustible construction is made by the local fire marshal, building inspector or the local safety authority having jurisdiction.*



### **Warning**

*This appliance should not be located closer than 12” to any adjacent combustible surface or under any overhead unprotected combustible construction*

Minimum clearances to combustible surfaces must be maintained when operating this appliance, and are as follows:

<u>Wall</u>	<u>Clearance</u>
Sides	12”
Back	12”

Twin Eagles Teppanyaki Griddle is ETL – approved for residential installation. Cutout must include a 4” (10.2cm) x 4” (10.2cm) opening for a side or bottom gas connection in two locations. The openings are indicated by the square, dashed cut outs in the diagram below. All dimensions shown are for planning purposes only.



**CUT OUT DIMENSIONS FOR BUILT-IN APPLICATIONS – TWIN EAGLES TEPPANYAKI GRIDDLE**

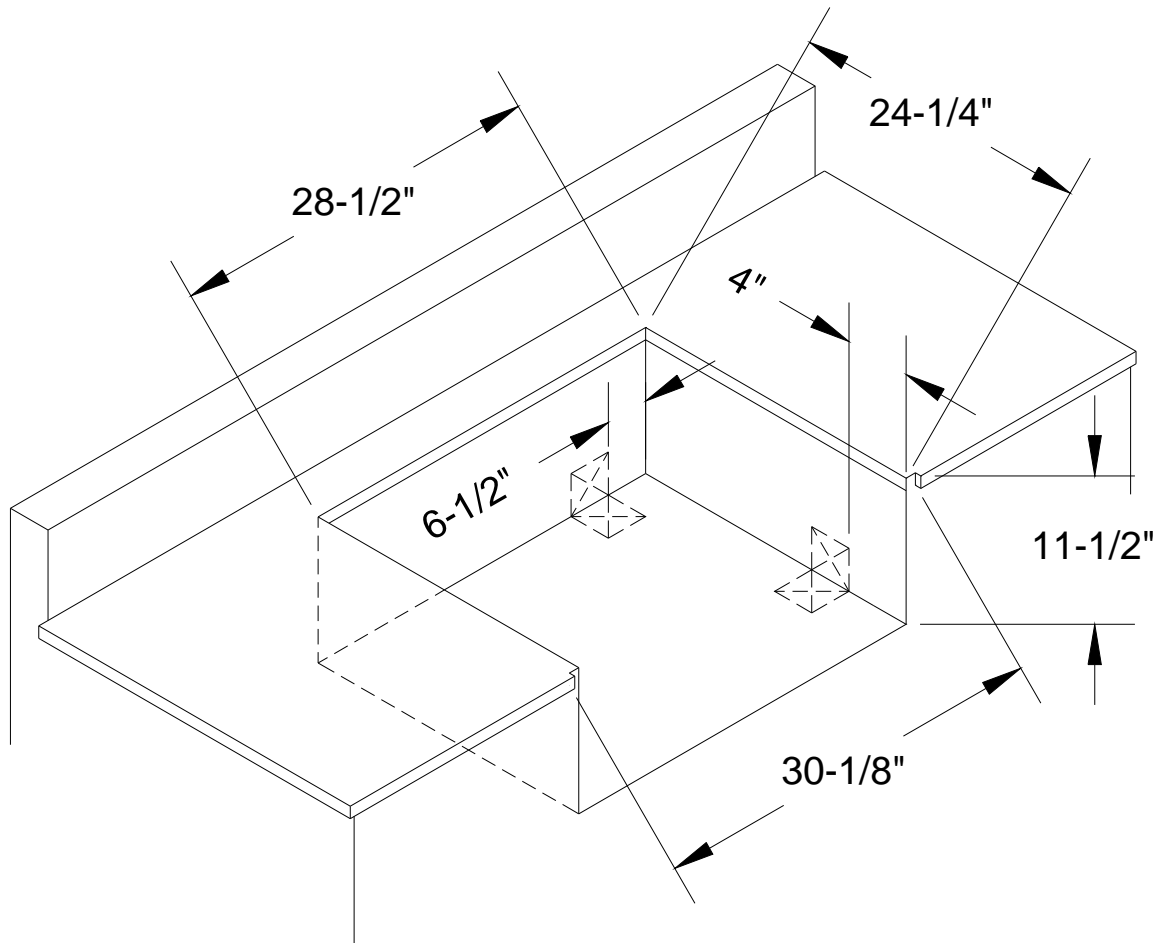

**Freestanding Applications:** The Twin Eagles Teppanyaki Griddle may be installed into the Twin Eagles 30" freestanding grill base (TEGB30-B). The freestanding configurations allow 12" from the sides and rear to combustible construction while in operation.



## **GAS REQUIREMENTS – TWIN EAGLES TEPPANYAKI GRIDDLE**

Each appliance is set and tested at the factory for the type of gas supply to be used. Identify the type of gas, either natural gas or LP gas and make sure that the marking on the rating/serial plate matches the gas being supplied to the griddle.

All gas connections should be made by a qualified technician and in accordance with local codes and ordinances. The installation must conform with local codes or, in the absence of local codes, with either the national Fuel Gas Code, ANSI Z223.1/NFPA 54, or CAN/CGA-B149.1, Natural Gas Installation Code or CAN/CGA-B149.2, Propane Installation Code.

All gas installations, conversions, and/or adjustments must be performed by an authorized service agent.

**WARNING:**

**CHECK TO ENSURE THAT THE GAS SUPPLY HOSE DOES NOT COME IN CONTACT WITH ANY HOT SURFACE OF THE GRIDDLE.**

**NEVER CONNECT THE GRIDDLE TO AN UNREGULATED GAS SUPPLY.**



## NATURAL GAS CONNECTION – TWIN EAGLES TEPPANYAKI GRIDDLE

- The regulator supplied is set for 4” water column and is for use with Natural gas only.
- The outdoor cooking gas appliance and its individual shutoff valve must be disconnected from the gas supply piping system during any pressure testing of that system at test pressures in excess of 1/2 psi (3.5 kPa).
- The outdoor cooking gas appliance must be isolated from the gas supply piping system by closing its individual manual shutoff valve during any pressure testing of the gas supply piping system at test pressures equal to or less than 1/2 psi.
- A typical natural gas installation is shown below. Make sure the factory supplied regulator is used and installed with the arrow mark on the regulator pointing in the same direction as the gas flow going from the supply line to the Teppanyaki Griddle. The regulator is preinstalled onto the end of the Manifold. Use only the regulator provided as original equipment with your Teppanyaki Griddle. Use only pipe sealants that are approved for use with natural and LP gases. An installer supplied gas shutoff valve must be installed in an accessible place.

**Caution: Provide adequate ventilation holes in the enclosure for safety purposes in the event of a gas leak.**

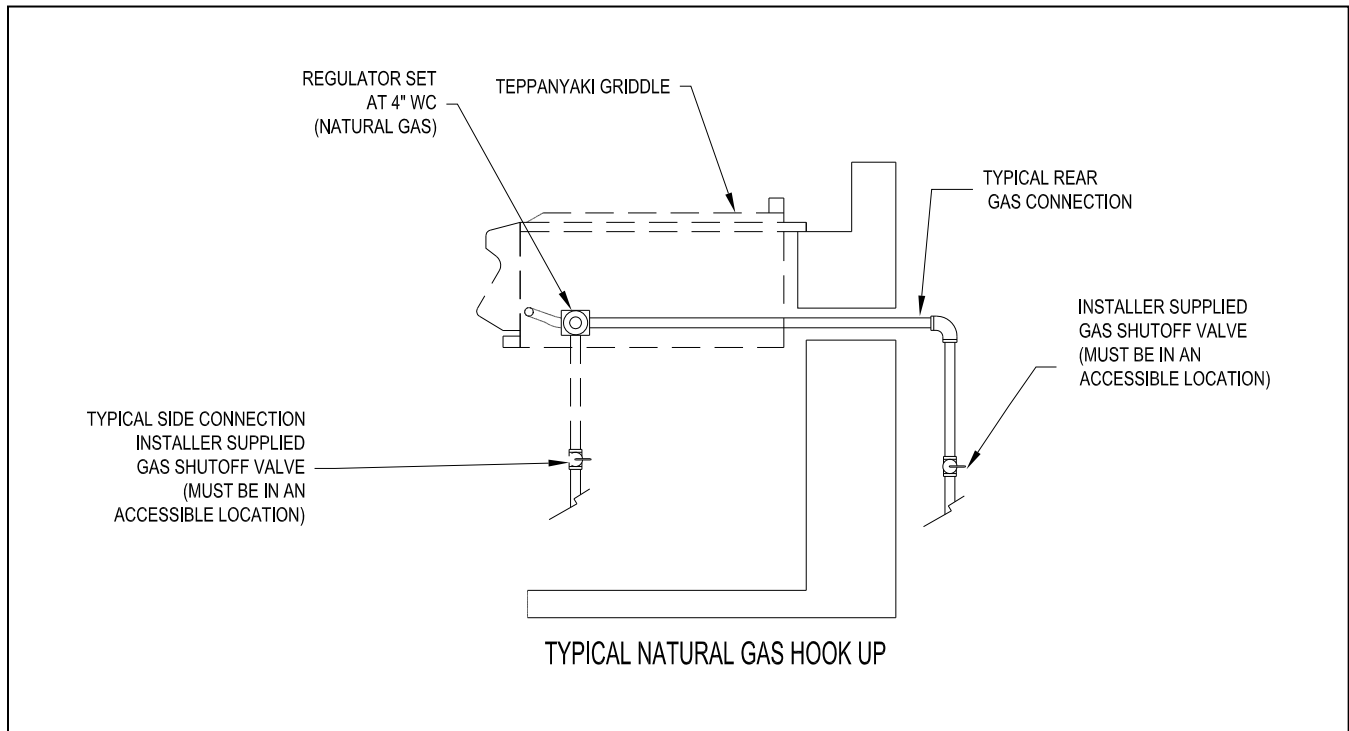

## LIQUID PROPANE GAS CONNECTION – TWIN EAGLES TEPPANYAKI GRIDDLE

If your Teppanyaki Griddle is for Liquid Propane application, a factory supplied L.P regulator is set for 11” WC and is for use with L.P. gas only. The factory-supplied regulator and hose must be used with a 20 lb. L.P. cylinder.

### **LP Gas Hose**

- The gas supply hose should be inspected prior to each use. Do not use a gas hose that has abrasions, cuts, or excessive wear.
- The gas supply must be turned off at the LP Gas supply cylinder and the LP Gas supply cylinder must be disconnected from the regulator when this outdoor cooking gas appliance is not in use.
- When your Teppanyaki Griddle is stored indoors, remove and store the LP Gas cylinder outdoors in a protected, cool, and dry location out of reach of children. The cylinder should not be stored in a building, garage, or any other enclosed area.

### **LP gas cylinder**

- Store the cylinder in an upright position so that the cylinder valve is at the top. This will ensure proper vapor withdrawal.
- The cylinder used must include a collar to protect the cylinder valve.
- Store any spare or extra gas cylinder(s) at least 15 feet from the Teppanyaki Griddle other open flame, heat-producing appliance(s) or heat source in a cool, well-ventilated outdoor location.

*Note: An enclosure for LP gas cylinder must be vented on the level of the cylinder valve and at floor level. The effectiveness of the opening(s) for purposes of ventilation shall be determined with the LP gas supply cylinder in place. This shall be accomplished by one of the following:*

- a. One side of the enclosure shall be fully open; or*
- b. For an enclosure having four sides, a top and a bottom: At least two ventilation openings at cylinder valve level shall be provided in the sidewall, equally sized, spaced at 180 degrees (3.14 rad), and unobstructed. Each opening shall have a total free area of not less than 1/2 square inch per pound (7.1 cm<sup>2</sup>/kg) of stored fuel capacity and not less than a total free area of 10 square inches (64.5 cm<sup>2</sup>).*
- c. Ventilation opening(s) shall be provided at floor level and shall have a total free area of not less than 1/2" square inch per pound (7.1 cm<sup>2</sup>/kg) of stored fuel capacity and not less than a total free area of 10 square inches (64.5 cm<sup>2</sup>). If ventilation openings at floor level are in a sidewall, there shall be at least two openings. The bottom of the openings shall be at floor level and the upper edge no more than 5 inches (127 mm) above the floor. The openings shall be equally sized, spaced at 180 degrees (3.14 rad) and unobstructed.*



## LIQUID PROPANE GAS CONNECTION – TWIN EAGLES TEPPANYAKI GRIDDLE

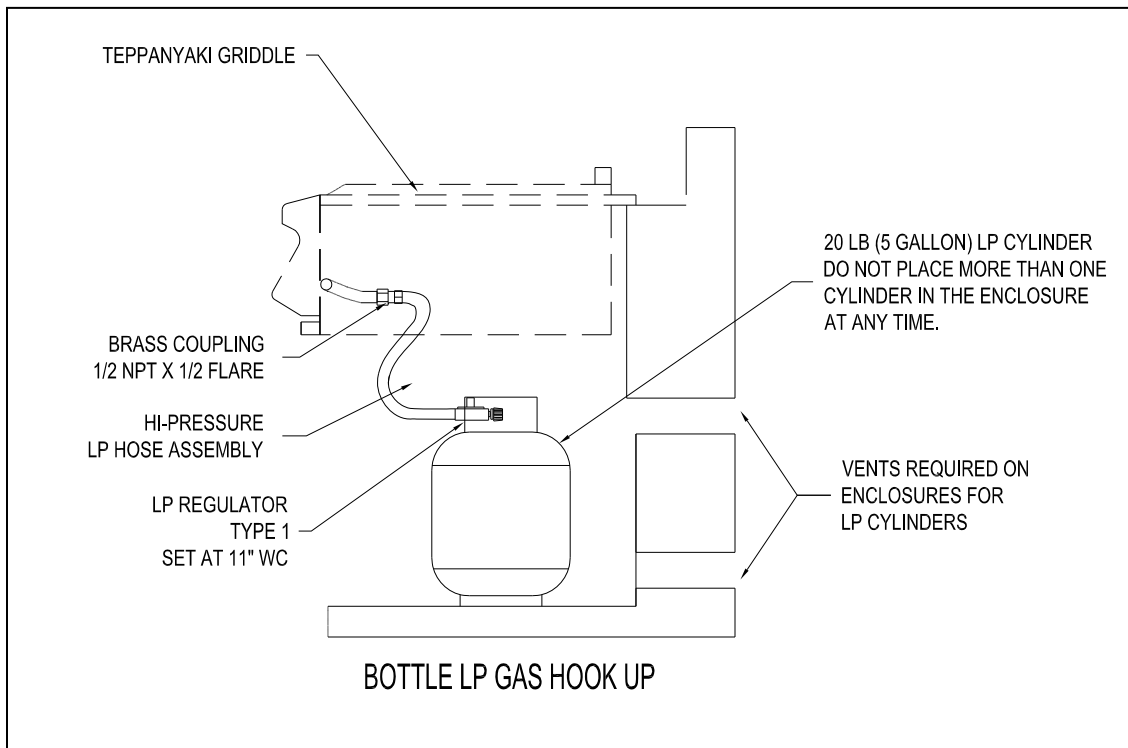

### Procedure for LP Gas Cylinder Connection (20 lbs)

1. Turn Hand Wheel on cylinder clockwise until it stops to ensure the Cylinder Valve is fully closed.
2. Turn all of the burner knobs to the OFF position.
3. Connect the 3/8" Flare end of the hose to the 3/8" Flare end of the brass coupling on the unit using a 3/4" open wrench. Do not apply pipe sealant.
4. Connect the regulator to the LP cylinder. Do not use any tools. Hand-tighten the regulator.
5. Check for leaks using a soapy water solution.
6. See figure above for a typical LP gas hook up.
7. To disconnect after use, turn the burner knob to the OFF position. Close the Cylinder Valve by turning the Hand Wheel counter-clockwise until it stops.
8. Disconnect the regulator from the LP cylinder after use.





## **Warning On Gas Leak**

- Finding and/or fixing a gas leak is NOT a “DO-IT-YOURSELF” procedure.
- NEVER USE THE GRIDDLE WITHOUT FIRST LEAK TESTING THE GAS CONNECTIONS.
- WARNING: DO NOT USE OPEN FLAME TO CHECK FOR LEAKS. USE OF AN OPEN FLAME COULD RESULT IN A FIRE, EXPLOSION AND BODILY HARM.
- DO NOT SMOKE WHILE PERFORMING THE LEAK TEST!
- To prevent fire or explosion hazard, DO NOT use or permit sources of ignition in the area while performing a leak test. Perform leak test outdoors only.
- Check to ensure that flexible hoses do not have any cuts and wear that may affect the safety before each use. Only the factory supplied hose and regulator must be used. Use only replacement regulator and hose assemblies specified by Twin Eagles.

## **LEAK TEST**

- 1) Prepare a leak testing solution of sudsy water by mixing in a spray bottle with half liquid soap and half water.
- 2) Confirm that all control knobs are in the OFF position.
- 3) Turn the main gas valve supply ON.
- 4) Apply leak testing solution by spraying on the pipe joints, fittings, and hose.
- 5) A gas leak is detected if;
  - a) there is a faint gas smell and/or...
  - b) ...growing bubbles appear on any of the connection points and/or hose, DO NOT attempt to ignite the griddle. IMMEDIATELY turn off the gas supply valve if a gas leak is determined.
- 6) When there is a gas leak, call a qualified service technician. DO NOT use the griddle until the leak is corrected.



## OPERATING INSTRUCTIONS – TWIN EAGLES TEPPANYAKI GRIDDLE

### Lighting Instructions (Griddle Plate)

1. Remove the cover from the Griddle Plate.
2. Ensure the Gas supply valve is closed and the burner knob is set to the OFF position.
3. Open the valve on the gas supply.
4. Flip the rocker switch to the **ON** position.
5. Push and turn the thermostat knob counterclockwise to the desired temperature setting. The burner **ON** light should glow when the griddle thermostat is turned on until the griddle plate reaches the temperature the thermostat knob was set to.
6. To shut down, turn the thermostat and rocker switch to the OFF position.
7. For complete shutdown, close the valve at the gas supply.

#### **CAUTION:**

- **Do not leave the Teppanyaki griddle unattended while cooking.**
- **THE GRIDDLE PLATE CAN NOT BE LIT MANUALLY**

## CLEANING AND MAINTENANCE – TWIN EAGLES TEPPANYAKI GRIDDLE

### General Overview

Proper care, maintenance, and cleaning will help ensure a long life of your Teppanyaki Griddle. Periodic cleaning will help avoid accumulations of flammable grease, fats, and other debris.

Some debris and residue may remain on the griddle plate. To remove this residue after cooking, simply dip a brass-bristle in tap water and scrub the hot plate.

**Caution:** *Always allow the Teppanyaki Griddle to cool before cleaning.*



### **Griddle Plate**

- After every use, thoroughly wipe it with a rough cloth to remove food particles and other residue.
- You may use hot soapy water to remove the cooked-in food and seasoning.
- Special griddle cleaners are commercially available which may be used to remove heavy soil build-up.
  - Rinse the griddle with room temperature water after using any of these cleaners. **Caution:** *Never flood a hot griddle with cold water! This promotes griddle warping and can cause the griddle plate to crack if continued over a period of time.*
- Dry the griddle plate and coat it lightly with vegetable oil or apply a non-stick cooking spray

### **Grease Tray**

- The grease tray collects grease, liquid and food particles. It is highly recommended to clean the tray after every use to avoid any possibility of a grease fire.
- Allow the tray and its contents to cool before cleaning. The grease tray is located in front of the griddle plate assembly. Slightly tilt the grease tray forward and lift the tray to remove it from the griddle plate assembly. Wipe the grease tray clean with a cloth and a hot soapy solution. Make sure the grease tray is fully inserted back into the Teppanyaki Griddle again.

### **Flue Cover Assembly**

The Flue Cover Assembly is located at the back of the griddle plate assembly. Wipe the flue cover clean with a cloth. You may also remove it for cleaning with a hot soapy solution. Make sure the flue cover is fully inserted back into the Teppanyaki Griddle again.

### **Spider and Insect Warning**

Spiders and other insects can nest in the burners and orifices of this and any other outdoor products, which causes the gas to flow from the front of the burner. This can create a dangerous condition that can cause a fire behind the valve panel, damaging the Teppanyaki Griddle and making it unsafe to operate.

Inspect the burners once a year, or if the Teppanyaki Griddle has not been used for more than a month or if any of the following conditions occur:

- 1. The smell of gas in conjunction with the burner flames appearing yellow.**
- 2. The griddle does not reach temperature.**
- 3. The griddle heats unevenly.**
- 4. The burner makes popping noise.**



# EXPLODED VIEW – TWIN EAGLES TEPPANYAKI GRIDDLE

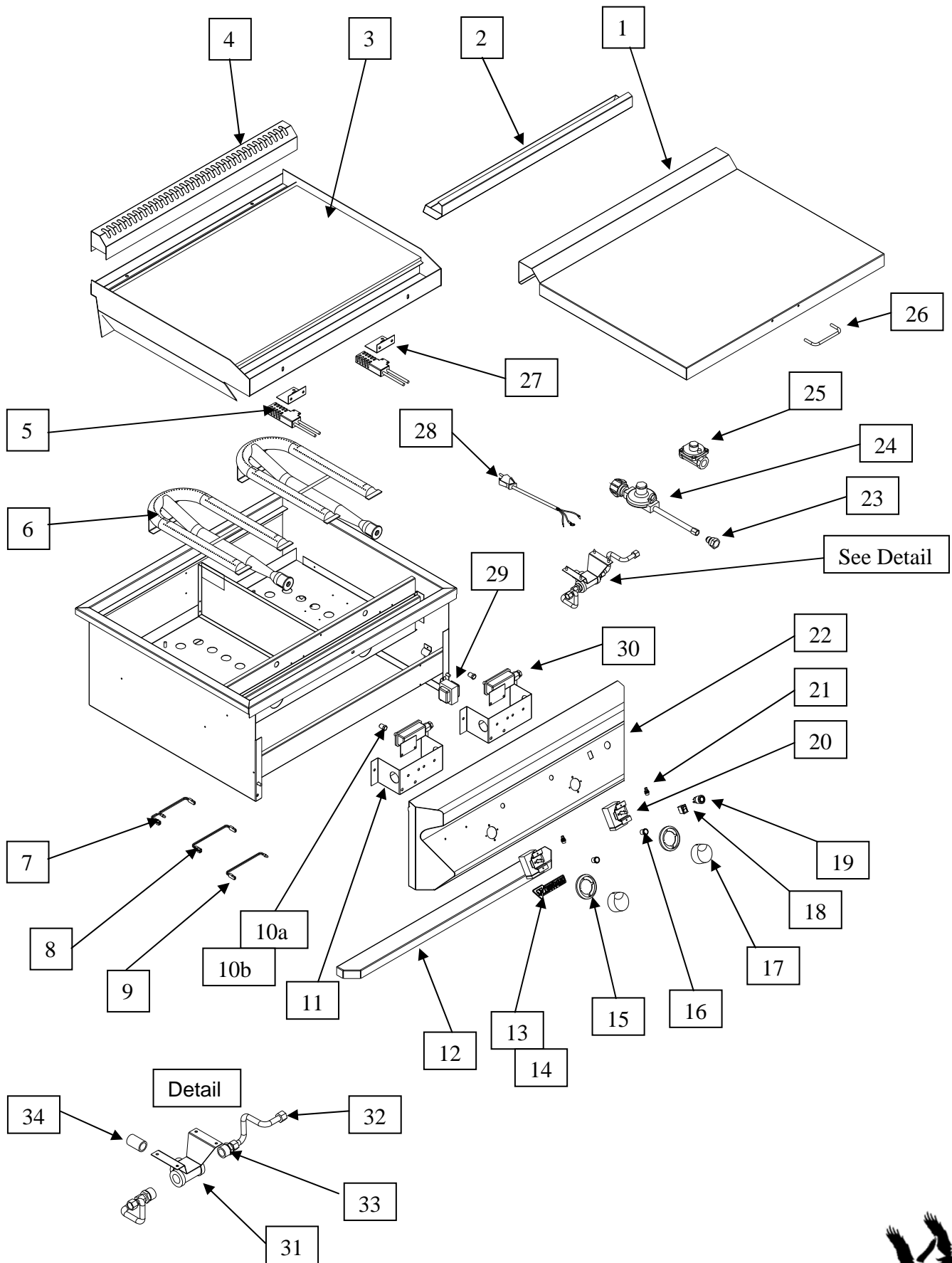

**REPLACEMENT PARTS LIST – TWIN EAGLES TEPPANYAKI GRIDDLE**

Item No.	TE Part Number	Description	TETG30-B
1	S20963	Cover Panel	1
2	S20959Y	Grease Tray	1
3	S11904Y	Teppanyaki Griddle Plate Assembly	1
4	S20960Y	Flue Cover Assembly	1
5	S16139	Hot Surface Igniter	2
6	S13301	Stainless Steel U6-burner (0.75 in. wall)	2
7	S16257	Wire Harness, Middle Blue LED	1
8	S16253	Wire Harness, LED No Light	1
9	S16256	Wire Harness, End Blue LED	1
10a	S15110-45	Orifice, #45 NG	2
10b	S15110-55	Orifice, #55 LP	2
11	S20966	Bi-metal valve Holder	2
12	S21745-3	False Handle	1
13	S13147	Twin Eagles USA Logo	1
14	S14160	Tinnerman Clip	2
15	S13136	Printed Chrome Knob Bezel	2
16	S16113	Red Pilot Light	2
17	S13154	Chrome Knob	2
18	S16131	Rocker Switch	1
19	S16196	Blue Illuminated Switch	1
20	S15312	Thermostat	2
21	S16192	LED Holder	2
22	S20961Y	Front Panel Assembly	1
23	S12602	Coupling, Brass 3/8 Flare x 1/2 FIP (LP Model Only)	1
24	S15302	LP Regulator (LP Models Only)	1
25	S15303	Natural Gas Regulator (NG Models Only)	1
26	S13117	Cover Panel Handle	1
27	S20908	Igniter Bracket	2
28	S16111	Power Chord	1
29	S16185	Transformer	1
30	S15111	Bi-metal Valve	2
31	S12617Y	Tee with Bracket	1
32	S12408	19" Stainless Flexible Tubing	2
33	S12641	Coupling, 3/8 cc x 1/2NPT	1
34	S12618	1/2 Close Nipple	1
	S16242	Wire Harness, Manifold LED (Not Shown)	1
	S16286Y	Wire Harness, Teppanyaki Griddle (Not Shown)	1





## TWIN EAGLES WARRANTY

**ONE-YEAR FULL WARRANTY:** Twin Eagles warrants the outdoor Teppanyaki Griddle and all of their component parts, to be free from defects in materials and workmanship under normal residential use for a period of one year from the original date of purchase. Twin Eagles will repair or replace, at its option, any part, which fail or is found to be defective during the warranty period, at no cost to the original purchaser. Warranty service must be performed by a Twin Eagles authorized representative during normal business hours.

### WARRANTY LIMITATIONS & EXCLUSIONS

This warranty shall apply only to the products purchased and located in the continental United States and Canada. The warranty coverage begins on the original date of purchase and proof of date of purchase is required. In order to activate the warranty, we require that you send in the attached warranty registration card. This warranty applies only to the original owner and may not be transferred.

This warranty does not apply to damages resulting from negligence, alteration, misuse, abuse, accident, natural disaster, loss of electrical power to the product for any reason, improper installation or improper operation, unauthorized adjustments or calibrations, dings, dents, scratches, or damages due to harsh cleaning chemicals. This warranty does not apply to commercial use, or to products with altered or removed serial numbers. Twin Eagles shall not be liable for incidental, consequential, special or contingent damages resulting from its breach of this written warranty or any implied warranty.

**WARRANTY SERVICE & REPLACEMENT PARTS:** Call your authorized selling dealer or call Twin Eagles directly at **800-789-2206**. Be prepared to furnish the following information: Purchaser's name, model and serial number of the appliance, date of purchase and the accurate description of the problem. Twin Eagles will not pay for service calls for correcting an installation problem. Owner shall be responsible for proper installation, providing normal care and maintenance, providing proof of purchase upon request and making the appliance accessible for service. In the event of any warranty replacement, all removal, replacement, installation and shipping costs are the responsibility of the grill owner.

Some states do not allow limitations on how long an implied warranty lasts, or the exclusions of or limitations on consequential damages. This warranty gives you specific legal rights and you may have other rights, which vary from state to state



## HOW TO OBTAIN SERVICE

For service, please contact your TWIN EAGLES dealer or call TWIN EAGLES direct at (800) 789-2206 or (562) 802-3488 or fax (562) 802-3391

Mailing address:

Twin Eagles, Inc.  
13231 East 166<sup>th</sup> Street  
Cerritos, CA 90703

Visit us at [www.twineaglesbbq.com](http://www.twineaglesbbq.com)

Please provide:

- Model number
- Serial Number
- Date of installation
- A description of the problem

Cut  
Here



## Warranty Registration

Customer Name

Model #

Address

Serial #

City

Date Purchased

Zip

Dealer's Name

Phone #

Dealer's Address

e-mail:

This Warranty Registration card must be returned within thirty days of purchased to properly activate your warranty. This information is for our internal use only.

Or you may fax the form at (562)802-3391 or register online at

<http://www.twineaglesbbq.com/contactus.shtml>



Cut  
Here



Place  
the  
Postage  
Here

ATTN: Warranty Department  
13231 East 166<sup>th</sup> Street  
Cerritos, CA 90703  
Fax no. (562) 802-3391

