



POST BARBECUE PATIO MOUNT

INSTALLATION AND OPERATING INSTRUCTIONS



SAFETY WARNINGS & CODES

Important: Read these instructions carefully before starting installation.

INSTALLER: Leave these instructions with consumer.
CONSUMER: Retain for future reference.

⚠ WARNING

1. Do not store or use gasoline or other flammable vapors and liquids in the vicinity of this or any other appliance.
2. A propane cylinder not connected for use shall not be stored in the vicinity of this or any other appliance.

⚠ WARNING

Improper installation, adjustment, alteration, service, or maintenance can cause injury or property damage. Refer to this manual. For assistance or additional information, consult a qualified professional installer, service agency, or the gas supplier.

⚠ DANGER

IF YOU SMELL GAS:

1. Shut off the gas to the appliance.
2. Extinguish any open flame.
3. Open lid if equipped with an oven.
4. If odor continues, keep away from the appliance, and immediately call the gas supplier or fire department.

Certified to ANSI: Z21.58-2007 / CSA 1.6-2007



CODE AND SUPPLY REQUIREMENTS: This barbecue must be installed in accordance with local codes and ordinances, or, in the absence of local codes, with either the latest *National Fuel Gas Code* (ANSI Z223.1/NFPA 54), and *Natural Gas and Propane Installation Code* (CAN/CGA-B149.1).

This appliance and its individual shutoff valves must be disconnected from the gas supply piping system when testing the system at pressures in excess of 1/2 psig (3.5 kPa).

This appliance must be isolated from the gas supply piping system by closing its individual manual shutoff valves during any pressure testing of the gas supply system at pressures up to and including 1/2 psig (3.5 kPa).

All electrical outlets in the vicinity of the barbecue must be properly grounded in accordance with local codes or, in the absence of local codes, with the *National Electrical Code, ANSI/NFPA 70, or the Canadian Electrical Code, CSA C22.1*, whichever is applicable.

Keep all electrical supply cords and fuel supply hoses away from any heated surface.



BÂTI DE PATIO DE BARBECUE DE POTEAU

INSTALLATION ET CONSIGNES D'UTILISATION



AVERTISSEMENTS ET CODES DE SÛRETÉ

Important: Lisez ces instructions soigneusement avant de commencer l'installation.

INSTALLATEUR: Laissez ces instructions avec le consommateur.

CONSUMMATEUR: Maintenez pour la future référence.

⚠ AVERTISSEMENT

1. Ne pas entreposer ni utiliser de l'essence ni d'autres vapeurs ou liquides inflammables dans le voisinage de l'appareil, ni de proximité de tout autre appareil.
2. Une bouteille de propane qui n'est pas raccordée en vue de son utilisation, ne doit pas être entreposée dans le voisinage de cet appareil ou de tout autre appareil.

⚠ AVERTISSEMENT

L'installation inexacte, l'ajustement, le changement, le service ou l'entretien peuvent causer des dommages ou des dégâts matériels. Référez-vous à ce manuel. Pour l'aide ou l'information additionnelle consultez un installateur qualifié et professionnel, l'agence de service, ou le fournisseur de gaz.

⚠ DANGER

S'il y a une odeur de gaz:

1. Coupez l'admission de gaz de l'appareil.
2. Éteindre toute flamme nue.
3. Ouvrir le couvercle.
4. Si l'odeur persiste, gardez loin de l'appareil, et appelez immédiatement le fournisseur de gaz ou le service d'incendie.

Certifié à la norme ANSI : Z21.58-2007 / CSA 1.6-2007



CONDITIONS DE CODE ET D'APPROVISIONNEMENT:

Cet barbecue doit être installé selon des codes et des ordonnances locaux, ou, en l'absence des codes locaux, avec l'un ou l'autre le plus défunt *code national de gaz de carburant* (norme ANSI Z223.1/NFPA 54), et le *code d'installation de gaz naturel et de propane* (CAN/CGA-B149.1).

Cet appareil et ses différents robinets d'isolement doivent être démontés du système sifflant d'offre de gaz en examinant le système aux pressions au-dessus du 1/2 psig (kPa 3.5).

Cet appareil doit être isolé dans le système sifflant d'offre de gaz par fermeture ses différents robinets d'isolement manuels pendant tous les essais sous pression du circuit d'alimentation de gaz aux pressions jusques et y compris le 1/2 psig (kPa 3.5).

Toutes les sorties électriques à proximité du barbecue doivent être correctement fondues selon des codes locaux ou, en l'absence des codes locaux, avec le *code électrique national, ANSI/NFPA 70, ou le code électrique canadien, CSA C22.1*, qui est jamais applicable.

Gardez tout cordon d'alimentation électrique et tuyau d'alimentation en combustible à l'écart des surfaces chauffées.

TABLE OF CONTENTS

SAFETY WARNINGS & CODES	1
PRODUCT DATA TABLE	3
PARTS LIST	5
DURING UNPACKING	6
PLANNING THE LOCATION OF THE POST BARBECUE	7
ENSURING PROPER COMBUSTION AIR AND COOLING AIR FLOW	7
ELECTRICAL OUTLETS	7
EXHAUST REMOVAL	7
INSTALLATION	7
GAS SUPPLY PLUMBING REQUIREMENTS	7
CONNECTING TO THE GAS SUPPLY	8
SECURING THE POST BARBECUE	8
SAFE USE & MAINTENANCE OF PROPANE-GAS CYLINDERS	9
CHECKING AND CONVERTING GAS TYPE	11
INSTALLING THE REGULATOR	11
CHECKING AND CONVERTING THE REGULATOR	11
CHECKING/CONVERTING THE BURNER ORIFICES	12
MAIN BURNER ORIFICE SIZE CHECKING/CONVERSION	12
MAIN BURNER AIR SHUTTER ADJUSTMENT	12
BACKBURNER ORIFICE SIZE CHECKING/CONVERSION (IF EQUIPPED)	13
BARBECUE SAFETY INFORMATION & MAINTENANCE	15
DRIP COLLECTION SYSTEM	15
SETTING THE TIMER	15
LIGHTING (IGNITION) INSTRUCTIONS	17
GRILL NOTES PAGE	18
RIGID SHELF INSTALLATION	19
ROTISSERIE INSTRUCTIONS	20
USING THE BACKBURNER AND ROTISSERIE	20
PUTTING THE MEAT ON THE SPIT ROD	20
RUNNING THE ROTISSERIE	20
ACCESSORIES	21
THE VAPORIZER PANEL(S)	21
THE DRIP PAN	21
THE WARMING RACK	21
CARE & CLEANING	22
COVER	22
REPLACING THE IGNITOR BATTERY	23
TROUBLESHOOTING	23
AMERICAN OUTDOOR GRILL LIMITED WARRANTY	24

PRODUCT DATA TABLE

Specification	Value
Main burner	
BTUs per burner	16,000
Natural gas orifice	#46 (2.057 mm)
Propane gas orifice	1.20 mm
Backburner (if equipped)	
BTUs per burner	10,000
Natural gas orifice	#54 (1.397 mm)
Propane gas orifice	#65 (0.889 mm)

Table 1 - Product data table

Avertissements généraux :

- Ce barbecue est pour utilisation à l'extérieur seulement. Si l'appareil est entreposé à l'intérieur, enlever les bouteilles et les laisser à l'extérieur.
- Ne pas ranger le gril immédiatement après l'avoir utilisé. le laisser refroidir avant de le déplacer ou de la ranger. Le non respect de cette mesure de sécurité pourrait entraîner un incendie causant des dommages à la propriété, des blessures ou la mort.
- Ne pas utiliser cet appareil sous une surface combustible.
- Ne pas utiliser cet appareil sous un auvent. Le non respect de cette mesure de sécurité pourrait entraîner un incendie ou des blessures.
- Dégagement minimal entre les parois latérales et l'arrière de l'appareil et la construction combustible (45.7 cm à partir des parois latérales et 45.7cm à partir de l'arrière).
- Le régulateur de pression de gaz prévu avec cet appareil de cuisson à gaz pour l'extérieur doit être utilisé. Ce régulateur est réglé pour une pression de sortie de 5 pouces de colonne de l'eau pour le gaz naturel, et 10 pouces pour le propane.
- LE RÉGULATEUR INCLUS D'APPAREILS EST ÉVALUÉ POUR LE MAXIMUM DE 1/2 (LIVRES PAR POUCE CARRÉ). SI VOTRE OFFRE DE GAZ EST 1/2 PLUS GRAND QUE (LIVRES PAR POUCE CARRÉ), UN RÉGULATEUR ADDITIONNEL DOIT ÊTRE INSTALLÉ AVANT LE BARBECUE. VOIR LA SECTION DE CONDITIONS D'OFFRE DE GAZ POUR LA PRESSION APPROPRIÉE D'OFFRE DE GAZ.
- Ne couvrez jamais la surface entière de cuisine ou de gril de gauffreuses ou de casseroles. La surchauffe se produira et les brûleurs ne seront pas très performants quand la chaleur de combustion est emprisonnée au-dessous de la surface à cuire.
- Ne pulvérisez jamais l'eau sur une unité chaude de gaz, comme ceci peut endommager des composants de porcelaine ou de fer de fonte.

Avertissements de propane :

- Une fuite de GPL peut causer un incendie ou une explosion si enflammée entraînant des blessures corporelles graves ou la mort.
- Communiquez avec le fournisseur de GPL pour les réparations ou pour disposer de qu'une bouteille ou du GPL non utilisé.

PARTS LIST

Item	Part #	Description
1.	24-B-11	Cooking grids (set of 2)
2.	24-B-05	Vaporizer panel (2)
3.	24-B-06	Main burner (2)
4.	24-B-25	Oven
5.	24-C-21	Rear access plate
6.	24-C-01	Shelf (2)
7.	24-C-18	Post base
8.	24-B-08	Valve manifold assembly
9.	3199-34	Ignitor
10.	24-B-26	Face assembly
11.	3015	Barbecue knobs (2)
12.	3016	Backburner knob *
13.	3083	Drip tray with match holder
14.	24-B-17	Backburner *
15.	24-C-20	Lag screw and shield (set of 4)
16.	24-B-10	Thermometer
17.	24-B-02	Warming rack *
18.	24-B-15	Heat shield

* if equipped

Replacement parts can be ordered from your local American Outdoor Grill dealer.

IMPORTANT
 Your AOG barbecue, oven and backburner (if equipped) are fully pre-assembled and tested at the factory.
DO NOT attempt to remove the oven and backburner from the barbecue prior to or during installation.
 Damage to the connecting gas line and ignitor wiring may occur.
 The plastic straps that secure the oven to the barbecue unit should be removed and discarded

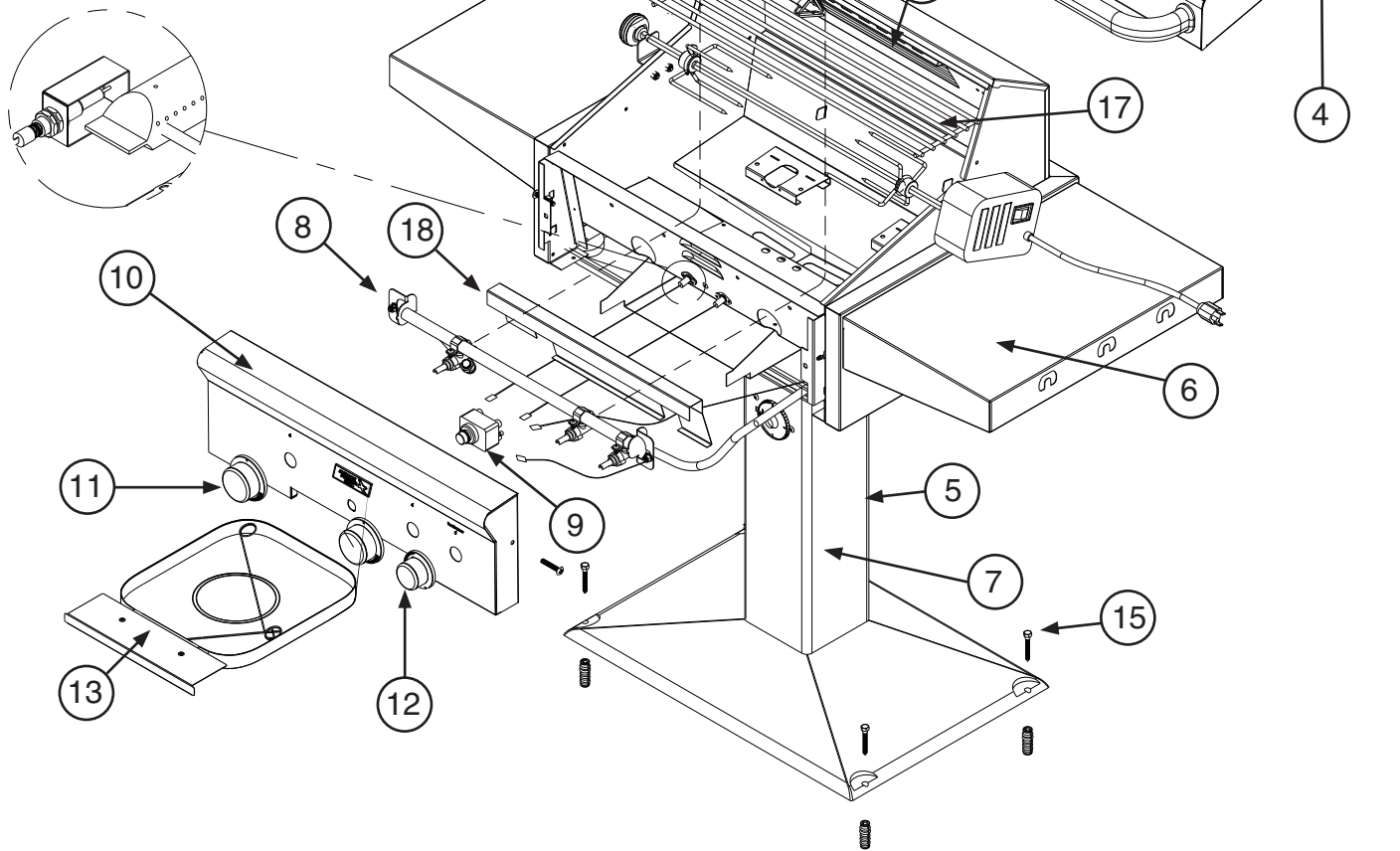

PARTS LIST (Cont.)

ROTISSERIE KIT (if equipped)

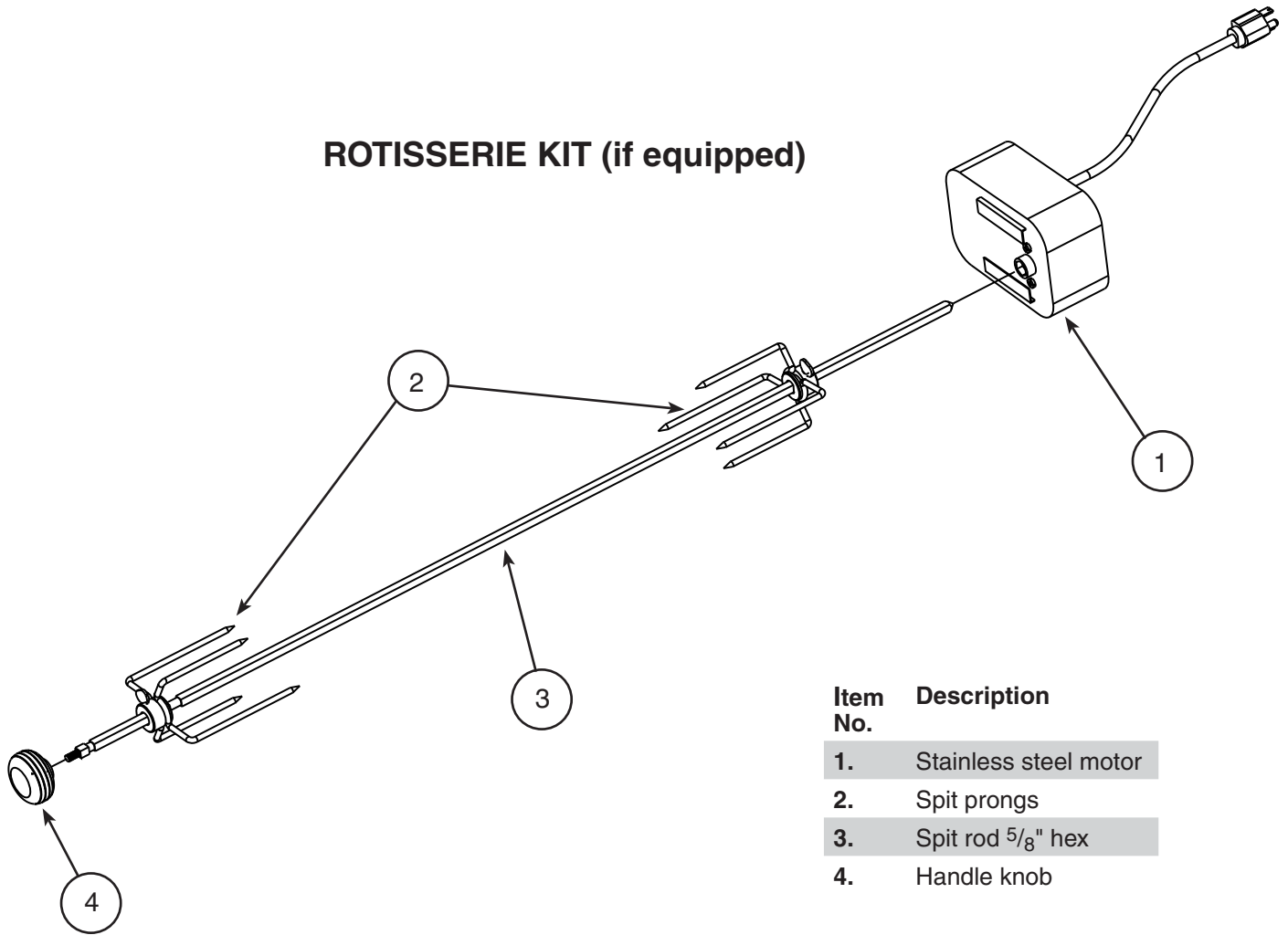

Item No.	Description
1.	Stainless steel motor
2.	Spit prongs
3.	Spit rod $\frac{5}{8}$ " hex
4.	Handle knob

DURING UNPACKING

Important: Tension bolt may have loosened during shipping, use adjustable nut to tighten, if necessary, before moving the barbecue.

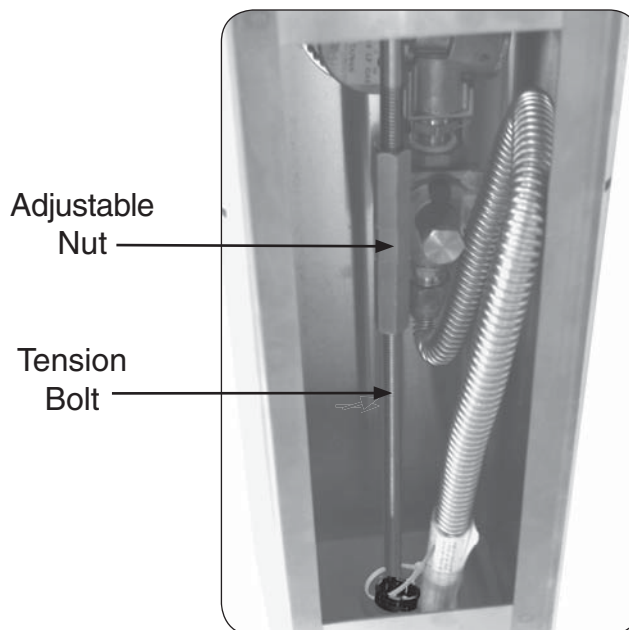

Fig. 6-1

PLANNING THE LOCATION OF THE POST BARBECUE

This barbecue is designed **FOR OUTDOOR USE ONLY**.

DO NOT use this unit under overhead combustible construction. **DO NOT** use this appliance inside a building, garage, or any unprotected, enclosed area (see EXHAUST REMOVAL). It must not be used in or on recreational vehicles or boats.

Important: This unit is **NOT** insulated and therefore during use it must be located with a minimum of 18" of side and back clearance from unprotected combustible materials such as wood, plastic, or stucco with wood framing.

ENSURING PROPER COMBUSTION AIR AND COOLING AIR FLOW

You must maintain proper air flow for the barbecue to perform as it was designed (Fig. 7-1). If airflow is blocked, overheating and poor combustion will result. Do not block the 1" front air inlet along the bottom of the face or more than 75% of the cooking grid surface with objects such as pans or griddles.



Fig. 7-1
Ventilation Diagram

products from the covered area. This barbecue shall not be used under unprotected overhead combustible construction. **THIS UNIT SHOULD NOT BE LOCATED IN A FULLY ENCLOSED AREA OF ANY KIND.**

CAUTION: Wind blowing into or across the rear oven lid vent (Fig. 7-2) can cause poor performance and/or dangerous overheating. Orient the grill so that the prevailing wind blows toward the front of the grill (Fig. 7-3).

CAUTION: To prevent dangerous overheating, the rear of the unit must have a minimum clearance of 4" from any backsplash/wall.

Note: The 1" front air space allows access to the drip tray.

ELECTRICAL OUTLETS

All electrical outlets in the vicinity of the barbecue must be properly grounded.

Note: Keep electrical supply cords away from all heated surfaces.

EXHAUST REMOVAL

If installed or used under a patio roof, the cooking grid area must be fully covered by a chimney and exhaust hood. An exhaust fan with a rating of 1,000 CFM (cubic feet per minute) or more may be necessary to efficiently remove smoke and other cooking by-



INSTALLATION

GAS SUPPLY PLUMBING REQUIREMENTS

For natural gas or a household propane system, rigid 1/2", or 3/4" black steel pipe, or local code approved pipe, is required to conduct the gas supply to the unit. An outdoor approved flexible connector can be used to connect your household gas supply to the barbecue. **DO NOT use a rubber hose within the enclosure for the barbecue unit.** Apply only joint compounds that are resistant to all gasses on all male pipe fittings. Make sure to tighten every joint securely.

Note: If 1/2" pipe is used with **natural gas**, it should be no longer than 20'.

Important: If you have a household propane supply, convert the regulator to use propane gas by following the instructions in the section entitled **CHECKING AND CONVERTING THE REGULATOR.**

Test all gas connections under pressure with a half-and-half soap and water solution. If the bubbles appear, there is a leak. Turn off the gas and tighten the connections. Then turn on the gas and repeat the leak test. Repeat until no leaks are detected. **Never use an open flame to test for leaks.**

Important: An external valve (with a removable key) in the gas line is necessary for safety when the barbecue is not in use. It also provides for convenient maintenance.

CONNECTING TO THE GAS SUPPLY

This post barbecue is capable of connecting to the gas supply in a few different ways. The connection can be made inside the post, under the post base, or out the back of the post.

The gas must be hooked up so that it passes through the timer (and regulator, if equipped) located in the post. To access the timer, unscrew and remove the access plate in the back of the post using a No. 3 Phillips-head screwdriver. Retain the screws.

To connect through the post, remove the knock-out disk at the bottom of the access plate with a large standard screwdriver by inserting the screwdriver into the notch provided in the center of the knock-out. Remove the plastic grommet fastened to the inside of the post and insert it into the newly created opening prior to passing the gas connection through the opening.

To connect through the post base, run the gas connection through the hole provided in the center of the post base.

When finished, replace access plate and tighten the four screws provided.

GAS SUPPLY AND MANIFOLD PRESSURES

For **natural gas** - Normal 7" water column (w.c.), minimum 5" w.c., maximum 10 1/2" w.c.

For **propane gas** - Normal 11" w.c., minimum 8" w.c., maximum 13" w.c.

SECURING THE POST BARBECUE

Important: BEFORE USE, the patio mount base must be securely fastened to a stable, level surface to ensure the grill remains fixed and upright at all times.

Locate the patio mount base in the planned grill location and mark the 4 holes. Drill the marked holes to a 1/2" diameter x 1 1/2" depth. Insert the lag shields (see PARTS LIST) into the holes, being sure that they are flush with the ground.

Align the holes on the patio mount base over the lag shields in the ground. Secure the base with the lag screws (see PARTS LIST) using a 7/16" nut driver.

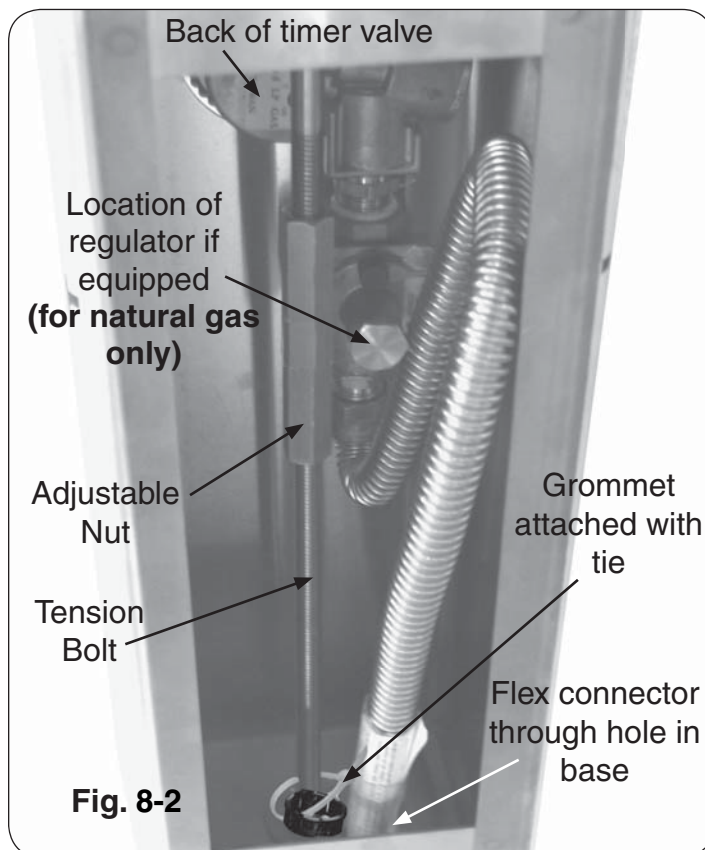

Fig. 8-2

Post (access panel removed)

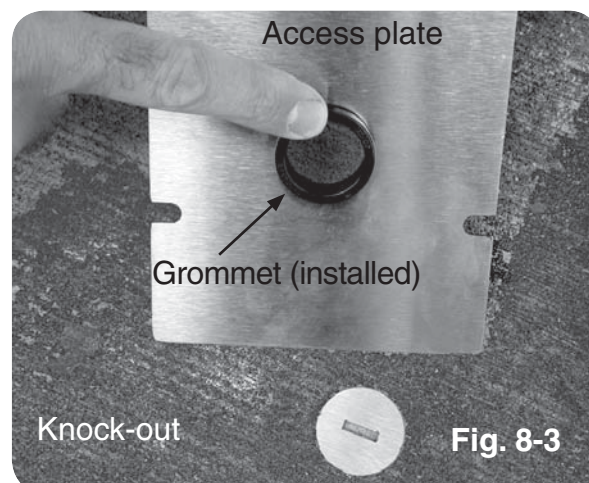

Fig. 8-3

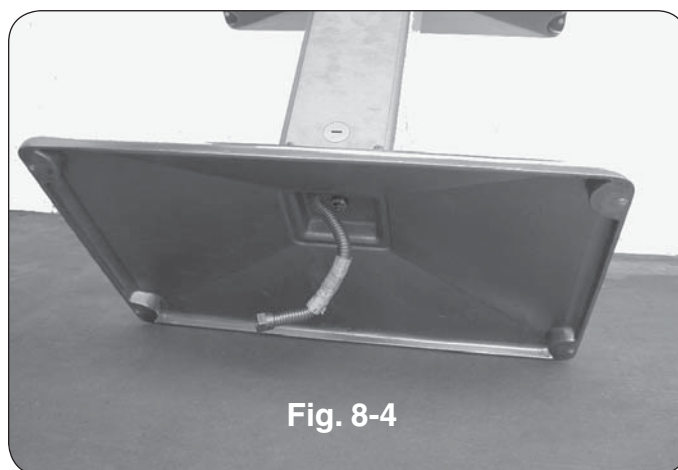

Fig. 8-4

SAFE USE & MAINTENANCE OF PROPANE GAS CYLINDERS

IMPORTANT FOR YOUR SAFETY

READ AND FOLLOW ALL WARNINGS PROVIDED WITH THE PROPANE-GAS CYLINDER.

When operating this appliance with a propane-gas cylinder, these instructions and warnings **MUST** be observed.

FAILURE TO DO SO MAY RESULT IN A SERIOUS FIRE OR EXPLOSION.

CYLINDER/CONNECTOR REQUIREMENTS

- a. Propane-gas cylinders, valves, and hoses must be maintained in good condition and must be replaced if there is visible damage to either the cylinder or valve. If the hose is cut or shows excessive abrasion or wear, it must be replaced before using the gas appliance (see e.).
- b. This unit, when used with a cylinder, should be connected to a standard 5-gallon (20 lb.) propane-gas cylinder equipped with an OPD (Overfill Prevention Device). The OPD has been required on all cylinders sold since October 1, 1998, to prevent overfilling.
- c. Cylinder dimensions should be approximately 12" (30.5 cm) in diameter and 18" (45.7 cm) high. Cylinders must be constructed and marked in accordance with the *Specifications for Propane Gas Cylinders of the U.S. Department of Transportation (D.O.T.)* or the National Standard of Canada, *CAN/CSA-B339, Cylinders, Spheres, and Tubes for Transportation of Dangerous Goods*.
- d. The cylinder used must include a collar to protect the cylinder valve, and the cylinder supply system must be arranged for vapor withdrawal.
- e. The pressure regulator and hose assembly used must match the specification for Type I by *ANSI Z 21.58-2005/CGA 1.6-2005* (see Fig. 9-1).
- f. The propane-gas cylinder valve must be equipped with a cylinder connection coupling device, described as Type I in the standard defined in paragraph e. above. This device is commonly described as an Acme thread quick coupler.
- g. If the propane-gas cylinder comes with a dust plug, place the dust cap on the cylinder valve outlet whenever the cylinder is not in use.

QUICK COUPLER OPERATION

To connect the regulator/hose assembly to the propane-gas cylinder valve fitting: Press the hand nut on the regulator over the Acme thread fitting on the cylinder valve. Turn the hand nut clockwise to engage the threads and tighten until snug.

The use of pliers or a wrench should not be necessary. Only cylinders marked "propane" may be used.

To disconnect: Turn the hand nut counterclockwise until detached (Fig. 9-1).

Important: Before using the unit, and after each time the cylinder is removed and reattached, check the hose for wear (see a.) and check all connections for leaks. Turn off the unit valves and open the main cylinder valve, then check connections with soapy water. Repair any leaks before lighting the unit.

CAUTION: Always turn the propane cylinder main valve off after each use, and before moving the unit and cylinder or disconnecting the coupling. This valve must remain closed and the cylinder disconnected while the appliance is not in use, even though the gas flow is stopped by a safety feature when the coupler is disconnected.

Carefully inspect the hose assembly each time before the gas is turned on. A cracked or frayed hose should be replaced immediately.

If the appliance is stored indoors, the cylinder must be disconnected and removed. Disconnected cylinders must be stored outdoors, out of the reach of children, with threaded valve plugs tightly installed, and must not be stored in a building, garage, or any other enclosed area.

FOR YOUR SAFETY

- a. DO NOT store a spare propane-gas cylinder under or near this appliance.
- b. NEVER fill the cylinder beyond 80-percent full.
- c. IF THE INFORMATION IN a. AND b. IS NOT FOLLOWED EXACTLY, A FIRE CAUSING DEATH OR SERIOUS INJURY MAY OCCUR.

Fig. 9-1 Type I Acme thread quick coupler

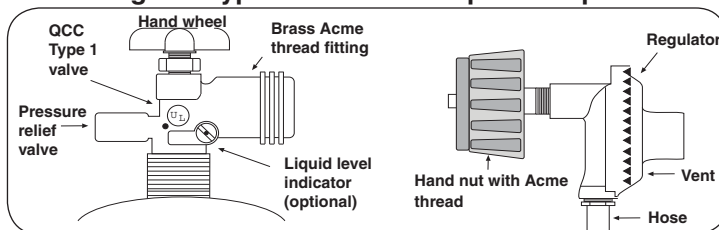

UTILISATION SÛRE ET ENTRETIEN DES CYLINDRES DE GAZ DE PROPANE

IMPORTANT POUR VOTRE SÛRETÉ

LISEZ ET SUIVEZ TOUS LES AVERTISSEMENTS ÉQUIPÉS DE VOTRE CYLINDRE DE GAZ DE PROPANE.

En actionnant cet appareil avec un cylindre de gaz de propane ON DOIT observer ces instructions et avertissements.

LE MANQUE DE FAIRE AINSI PEUT AVOIR COMME CONSÉQUENCE UNE INCENDIE OU UNE EXPLOSION SÉRIEUSE.

CYLINDRE ET CONDITIONS ET

CARACTÉRISTIQUES DE CONNECTEUR

- Des cylindres et les valves de gaz de propane doivent être maintenus en bon état et doivent être remplacés s'il y a des dommages évidents au cylindre ou à la valve.
- Ce gril, une fois utilisé avec un cylindre, devrait être relié à un gallon de la norme 5 (20lb.) cylindre de gaz de propane équipé d'un OPD (remplissez au-dessus du niveau le dispositif d'empêchement). L'OPD a été exigé sur tous les cylindres vendus depuis octobre 1.1998 pour empêcher le remplissage excessif.
- Les dimensions de cylindre devraient être approximativement 12" (30.5cm) de diamètre et 18" (45.7cm) hauts. Des cylindres doivent être construits et marqués selon les caractéristiques pour des cylindres de gaz de propane du département des ETATS-UNIS du transport (D.O.T.) ou le niveau national du Canada, du CAN/CSA-B339, des cylindres, des sphères et des tubes pour le transport des marchandises dangereuses.
- Le cylindre doit inclure un collier pour protéger la valve de cylindre et le circuit d'alimentation de cylindre doit être assuré le retrait de vapeur.
- Le régulateur de pression et l'ensemble de tuyau utilisé doivent assortir les spécifications pour le type I par ANSI Z 21.58-2005/CGA 1.6-2005 (voir la figue. 10-1).
- La valve de cylindre de gaz de propane doit être équipée d'un dispositif d'accouplement de raccordement de cylindre, décrit comme type I dans la norme définie dans le e. de paragraphe ci-dessus. Ce dispositif est généralement décrit comme coupleur rapide de fil de point culminant.
- Si votre cylindre de gaz de propane vient avec une prise de la poussière, placez le bouchon anti-poussière sur la sortie de valve de cylindre toutes les fois que le cylindre n'est pas en service.

OPÉRATION DE COUPLEUR RAPIDE

Pour relier le regulator/hose à l'ajustage de précision de valve de cylindre de gaz de propane: Serrez l'écrou de main sur le régulateur au-dessus de l'ajustage de précision de fil de point culminant sur la valve de cylindre. Tournez l'écrou de

main dans le sens des aiguilles d'une montre pour engager les fils et pour serrer jusqu'à ce que douillettement. L'utilisation des pinces ou de la clé ne devrait pas être nécessaire. Seulement le propane marqué par cylindres doit être employé.

Pour débrancher: Tournez l'écrou de main dans le sens contraire des aiguilles d'une montre jusqu'à isolé (fig. 10-1).

Important: Avant d'employer le gril, et ensuite chaque fois que le cylindre est enlevé et rattaché, examinez tous les raccordements pour déceler les fuites. Arrêtez les valves de gril et ouvrez la valve principale de cylindre, puis vérifiez les raccordements avec de l'eau savonneux. Réparez toutes les fuites avant d'allumer le gril.

ATTENTION: Tournez toujours la valve principale de cylindre de propane au loin après chaque utilisation, et avant de déplacer le gril et le cylindre, ou débrancher l'accouplement. Cette valve doit rester fermée et le cylindre a débranché alors que l'appareil n'est pas en service, quoique l'écoulement de gaz soit arrêté par un dispositif de sûreté quand le coupleur est débranché.

Inspectez soigneusement l'ensemble de tuyau chaque fois avant que le gaz soit allumé. Un tuyau criqué ou frangé devrait être remplacé immédiatement.

Si l'appareil est stocké à l'intérieur, le cylindre doit être disconnected et a enlevé. Des cylindres Disconnected doivent être stockés dehors, hors de la portée des enfants, avec les prises de valve filettées étroitement installées, et ne doivent pas être stockés dans un bâtiment, le garage, ou n'importe quel autre secteur inclus.

POUR VOTRE SÛRETÉ

- Ne stockez pas un cylindre de gaz disponible de propane dessous ou ne vous approchez pas de cet appareil.
- Ne remplissez jamais cylindre au delà de 80 pour cent de plein.
- SI L'INFORMATION DANS "A" ET "B" N'EST PAS SUIVIE EXACTEMENT, UN FEU CAUSANT LA MORT OU DES DOMMAGES SÉRIEUX PEUT SE PRODUIRE.

Fig. 10-1 type coupleur rapide de fil de point culminant d'I

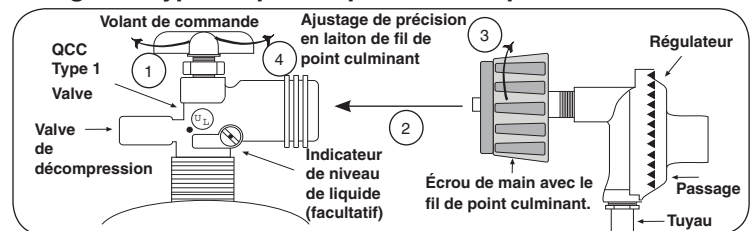

CHECKING AND CONVERTING GAS TYPE

This unit comes from the factory configured for one type of gas, as marked on the label behind the faceplate.

Converting this unit to burn a different type of gas requires a conversion kit from the factory. The professional installer who converts this unit to burn a different gas must perform the following functions:

1. Change brass gas orifices (included at original shipping) on each burner to match the new gas type (see PRODUCT DATA TABLE, Table 1).
2. Switch the convertible gas regulator (included at original shipping) to match the new gas type (see below).
3. Plumb the unit to the new gas supply.
4. Apply a new label behind the faceplate, indicating the new gas the unit will burn (included with conversion kit).

WARNING

HAZARDOUS OVERHEATING WILL OCCUR IF A NATURAL-GAS ORIFICE IS USED WITH PROPANE GAS. IF YOU ARE NOT SURE IF THE CORRECT ORIFICES ARE INSTALLED, OR IF AN ORIFICE CHANGE IS NECESSARY, REFER TO THE FOLLOWING INSTRUCTIONS.

CAUTION: Make sure the unit is at a safe temperature and isolated from gas and electrical supplies before beginning the tasks outlined below.

Note: The cooler the unit, the greater the tolerances between the stainless-steel parts, and therefore the easier to disassemble and reassemble parts of the unit.

CAUTION: For your safety, exercise caution and use adequate hand protection (such as gloves) when handling potentially sharp sheet-metal parts.

CHECKING AND CONVERTING THE REGULATOR

Regulator: note the cap on top

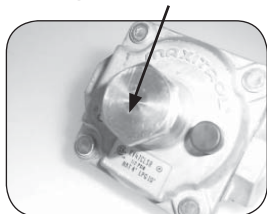

Note: Each end of the plastic converter is engraved with either the letters "NAT" or "L.P." (propane) for the respective gasses. When the converter is in the cap and the cap is held uppermost, the letters seen indicate the gas that the regulator is set up for.

To convert the regulator from one gas to another, follow steps 1-4.



STEP 1: Unscrew and remove the cap from the regulator, extracting the converter.



Read gas type here

STEP 3: Turn the converter around and replace it carefully, into the center of the cap (it will snap into place). Check that you can read the type of gas the unit is set for.



STEP 2: Remove the converter (the plastic stalk) by carefully pulling it away from the center of the cap (it will snap out of its seating).

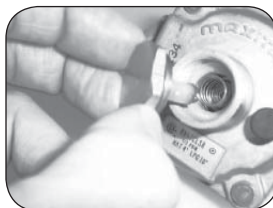

STEP 4: Replace the unit into the regulator and screw down until snug.

WARNING

THIS APPLIANCE REGULATOR IS RATED FOR 1/2 PSI MAXIMUM. IF YOUR GAS SUPPLY IS GREATER THAN 1/2 PSI, AN ADDITIONAL REGULATOR MUST BE INSTALLED TO REDUCE THE INPUT PRESSURE TO THE UNIT TO 1/2 PSI OR LESS. SEE GAS-SUPPLY REQUIREMENTS SECTION FOR PROPER GAS-SUPPLY PRESSURE.

CHECKING/CONVERTING THE BURNER ORIFICES

MAIN BURNER ORIFICE SIZE CHECKING/ CONVERSION

Before beginning, make sure you have the proper tools for the task.

This task requires:

- a #2 Phillips-head screwdriver
- a deep $\frac{3}{8}$ " nut driver with a spacer (#6 nut)

Note: It may be necessary to remove the rotisserie rod before beginning this procedure.

1. Remove cooking grids & vaporizer panels from the barbecue.
2. **Turn the burner valves to the OFF position.** Pull the valve knobs from their stems and set them aside. Using a Phillips screwdriver, unscrew the face fastener screws, (located on the sides of the face) and remove the face from the barbecue. Retain the screws and finish washers for reattaching the face.

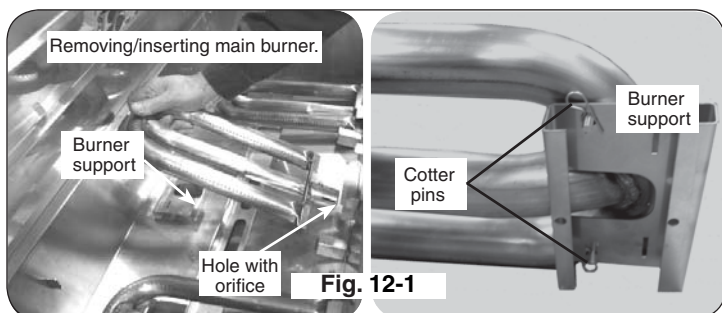

Note: Carefully, lift the face away from the frame. The spark generator for the ignition system is attached to the inside of the face panel. The spark generator knob need not be detached, but the wires must be unplugged from the generator before the face is completely removed (see Fig. 12-2).

3. Remove the two cotter pins from underneath the rear burner support and set them aside. Then carefully lift the burner from the rear burner-support and out from the hole in the forward fire wall (see Fig. 12-1).

4. Using a $\frac{3}{8}$ " socket, remove the orifice from the valve. Access this through the hole in the forward firebox plate (see PARTS LIST and Fig. 12-1). Check the number stamped on the face of the orifice (see Table 1). Repeat for each burner as necessary.

5. If the barbecue does not have the proper orifices installed for the gas supply you intend to use, replace them with the correct orifices. Some orifices were supplied with the barbecue. They may also be obtained from the conversion kit or supplied by your local dealer.

Note: A regulator hose will need to be connected for conversion to propane gas.

6. After checking the orifice drill size or replacing the orifice, replace the burner over the orifice fitting, sliding it forward,

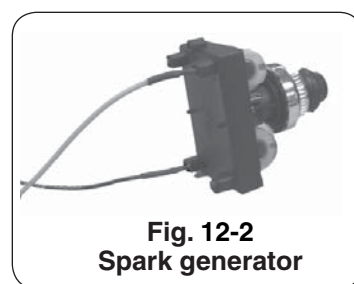

from behind the forward fire wall, so the orifice is centered inside the burner gas inlet, and set it gently onto the rear burner-support. The threaded studs on the bottom back of the burner must each fit through their respective holes in the rear burner-support. This is critical to the safe function of the barbecue. Finally, re-attach the cotter pins from step 3 around the studs (see Fig. 12-1).

MAIN BURNER AIR SHUTTER ADJUSTMENT

INSTALL THE VAPORIZER PANELS

Place the vaporizer panels directly on the support bracket above the burners. The panels allow heat from the burners to be evenly distributed throughout the cooking area. The panels are stainless steel and will heat and cool quickly, making your barbecue very responsive to the changes you specify in

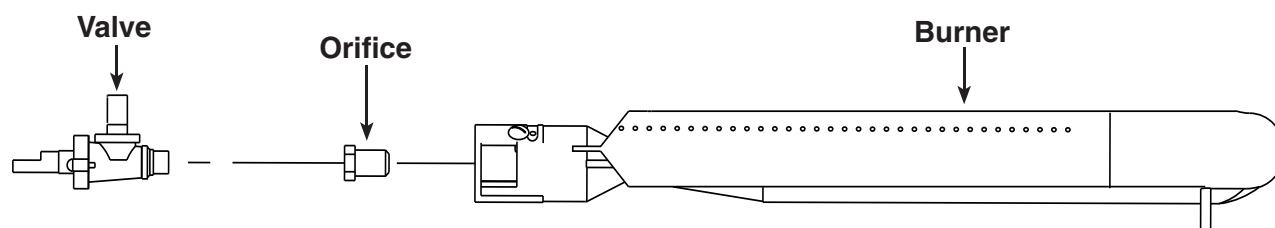

Fig. 12-3 - Burner orifice diagram

CHECKING/CONVERTING THE BURNER ORIFICES (Cont.)

grill temperature. They are rust resistant and may be cleaned with standard oven cleaners. Some discoloring will be seen with use. This is normal for stainless steel and does not affect the function.

ADJUSTING YOUR BARBECUE

Important: This appliance may not light or heat evenly or cook properly unless the air shutters are adjusted following installation (see AIR SHUTTER ADJUSTMENT section).

Burner air shutters are easily accessed by removing the front face panel. The air shutters are located on the front portion of each burner and have a locking screw that prevents the air shutter from inadvertent movement (see Fig. 13-1).

To close or open the air shutters, simply loosen the locking screw, using a long stemmed Phillips screwdriver, and turn the air shutter to open or close it.

Tighten the screws down when the desired setting is achieved.

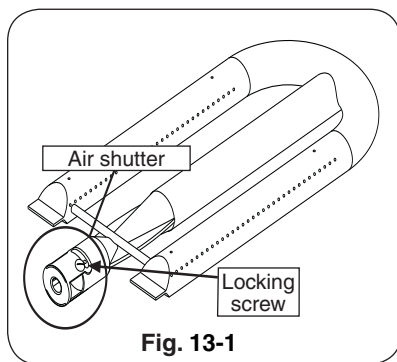

Fig. 13-1

AIR SHUTTER ADJUSTMENT

Light the burner to be adjusted in accordance with the LIGHTING INSTRUCTIONS and burn for 2 minutes with the burner control knob set to **HIGH** and the oven open. After burning for 2 minutes, open the air shutter until the flames lift off, or appear not to be touching the burner. Then begin closing the air shutter until the flames appear to burn while

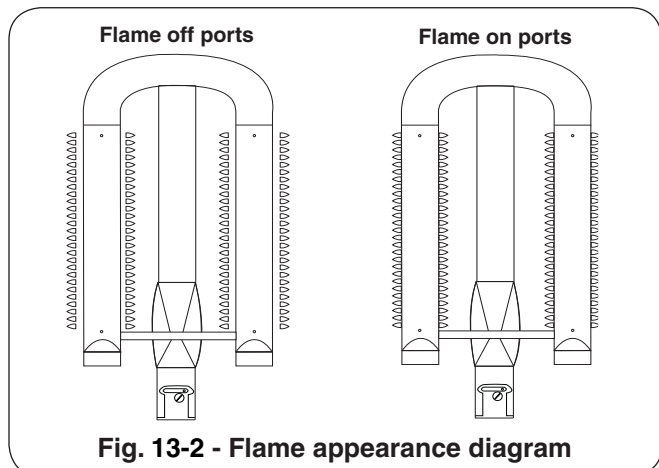

Fig. 13-2 - Flame appearance diagram

touching the burner ports (Fig. 13-2). You may then see short yellow tips on the flames. If flames are a lazy yellow, open the air shutters until the flame is blue with yellow tipping.

Note: Barbecues in some installations achieve a better air/gas mixture and will ignite more quickly if the valve is first turned beyond **HIGH** to **MEDIUM** or **LOW** for lighting.

BACKBURNER ORIFICE SIZE CHECKING/CONVERSION (IF EQUIPPED)

Before beginning, make sure you have the proper tools for the task.

This task requires:

- a 1/4" nutdriver
- a 3/8" wrench or socket screwdriver

Note: It may be necessary to remove the rotisserie rod before beginning this procedure.

1. Remove the backburner assembly as follows:

- a. Remove the backburner electrode mounting screw (1/4" hex) (see Fig. 13-3) and loosen the electrode. Draw the wire attached to the electrode down through the slot in the bottom of the bracket so that the left side of the backburner is free to be removed.
- b. Remove the backburner mounting screws (1/4" hex) located at the left end of the backburner assembly (see Fig. 13-3).

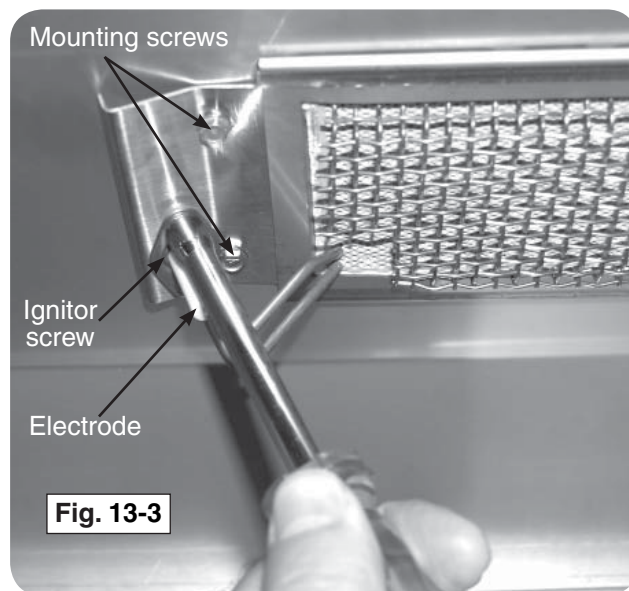

Fig. 13-3

Remove electrode and backburner mounting screws.

BARBECUE SAFETY INFORMATION & MAINTENANCE

Each time you use the barbecue, make sure that:

1. The area around the barbecue is clear of flammable vapors, liquids, and substances such as gasoline, yard debris, wood, etc.
2. There is no blockage of the airflow through the vent space located below the face of the unit.
3. When using propane gas:
 - a. The special ventilation openings in the enclosure should be kept free and clear of debris (see **PLANNING THE LOCATION OF THE BARBECUE**).
 - b. If connected to a propane cylinder, the rubber hose attached to the regulator should be carefully inspected before each use.
 - c. The propane cylinder, regulator, and rubber hose should be installed in a location not subject to heating above 125° F (51° C).
4. The burner flames burn evenly along both sides of each burner with a steady flame, which is mostly blue with yellow tipping. (Refer to section on **AIR SHUTTER ADJUSTMENT**.) If burner flames are not normal, check the orifice and burner for insects or insect nests.
5. The inline gas valve or gas cylinder valve is always shut **OFF** when the barbecue is not in use.
6. The drip collector hole is clear and unobstructed. Excessive grease deposits can result in a grease fire.
7. The barbecue is free and clear from combustible materials, gasoline, and other flammable vapors and liquids.
8. Do not operate the backburner with its cover installed.

DRIP COLLECTION SYSTEM

The drip collector in this barbecue is part of the unit's main frame and is located below the burners. The drip collector has one hole that will allow excess drippings to fall through during cooking, while separating the firebox from the drip tray. Clean the drip tray after each use.

The drip collector allows you to brush or scrape residue from the barbecue's inner liner into the drip tray. Following the manufacturer's instructions and regular cleaning of the barbecue's interior with oven cleaner, will help to prevent grease fires.

Periodically check the burners to make sure they are clear of debris. Properly adjusted burner flames burn evenly along both sides of each burner with a steady flame (mostly blue with yellow tipping). If burner flames are not normal, check the orifice and burner for insects or insect nests. (See section on **CHECKING/CONVERTING THE BURNER ORIFICES** for instructions on burner removal and replacement.)

Check the burner ports at least annually for blockage by removing the burner (see orifice changing instructions) and visually inspect the gas intake tube for insects and nests. A clogged tube can lead to a fire beneath the grill.

SETTING THE TIMER

Before following the **LIGHTING INSTRUCTIONS** section, set the timer located on the front of the post base to the desired number of cooking hours (up to three hours) by rotating the timer knob clockwise. The timer will slowly turn counterclockwise until it reaches the **OFF** position and then shut off the gas supply to the barbecue. To extend cooking time, turn the knob clockwise until it is set to the desired remaining cooking time.



Timer knob in OFF position

WARNING

KEEP THE TIMER KNOB FREE AND CLEAR OF ALL OBSTRUCTIONS AT ALL TIMES.

WARNING

NEVER cover the *entire* cooking or grill surface with griddles or pans. Overheating will occur and burners will not perform properly when combustion heat is trapped below the cooking surface.

CAUTION: NEVER spray water on a hot gas unit.

ALLUMER DES INSTRUCTIONS (D'ALLUMAGE)

Lisez les instructions entières avant que s'allumant et suivez ces instructions chaque fois vous lumière le barbecue.

ÉCLAIRAGE ÉLECTRONIQUE

1. Ouvrez tous les couvercles et enlevez toutes les couvertures des brûleurs que vous souhaitez vous allumer.
2. Arrêtez tous les boutons de commande de gaz à leurs positions.

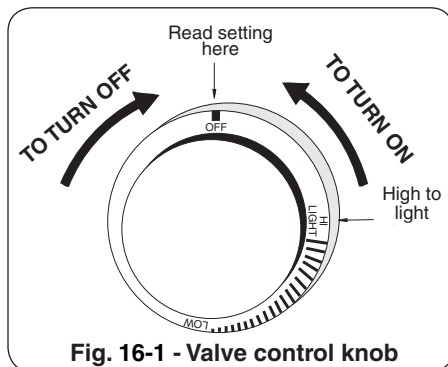

Fig. 16-1 - Valve control knob

Note: Aucune matière que la méthode d'éclairage vous emploient, n'allument pas le gaz à plus d'un brûleur à la fois. Les brûleurs adjacents de barbecue croix-mettront à feu.

3. Allumez le gaz à sa source.
4. Placez le bouton de commande de temporisateur (voir la page précédente) au temps de cuisson désiré.

ATTENTION: Si les brûleurs ne s'allument pas dans 5 secondes, enfoncez le bouton de commande et tournez le bouton à AU LOIN. ATTENDEZ 5 MINUTES avant de répéter l'étape 5. Si vous sentez le gaz suivez les instructions sur la couverture de ce manuel. Si les brûleurs ne s'allument toujours pas après que plusieurs tentatives, se rapportent à la section LÉGÈRE MANUELLE.

5. Enfoncez le bouton de commande pour que le brûleur soit allumé et tournez-le dans la position LÉGÈRE de HI, puis appuyez sur le bouton d'allumage. Une fois que le brûleur s'allume, libérez le bouton d'allumage.
6. Répétez l'étape 5 pour que chaque brûleur additionnel soit s'est allumé.

Note: Les barbecues dans quelques installations réalisent un meilleur mélange d'air/gas et mettront à feu plus rapidement si le bouton de commande de brûleur est d'abord tourné au delà de la LUMIÈRE de HI au BAS pour l'éclairage.



Fig. 16-3 - Éclairage manuel

RAPPELEZ-VOUS: POUR L'ÉCLAIRAGE MANUEL SÛR, PLACEZ Un ALLUMEUR BRÛLANT D'ALLUMETTE OU De BUTANE PRÈS Du BRÛLEUR - ALLUMEZ ALORS Le GAZ (Fig. 16-3).

POUR LE PROPANE SEULEMENT

Les réservoirs de propane sont équipés d'un dispositif d'arrêt de sûreté qui peut ne pas causer le bas ou aucun gaz pression/flame aux brûleurs si le fonctionnement et allumer des instructions ne sont pas suivis exactement. (voir la note importante dans la section de dépannage pour plus de détails.)

ÉCLAIRAGE MANUEL

ATTENTION: Attendez toujours 5 minutes le gaz à l'espace libre après que n'importe quelle tentative non réussie d'éclairage.

1. Suivez les étapes 1 à 4 (à gauche).
2. Insérez un allumeur brûlant de butane de long-baril, une allumette brûlante de long-tige, ou une allumette brûlante tenue par un support de prolongation de fil (Fig.16-2) par les grilles à cuire au brûleur. (Fig.16-3). Pour des backburners, tenez la flamme contre le matériel perforé du backburner. Pour des sideburners, tenez la flamme contre le brûleur.

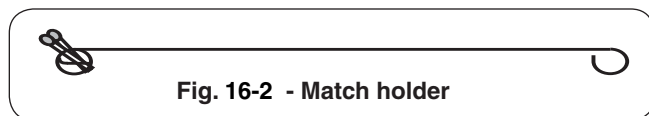

Fig. 16-2 - Match holder

3. Tout en tenant l'allumette ou la flamme plus légère à côté du brûleur, enfoncez le bouton de commande approprié de brûleur et tournez-le dans le sens contraire des aiguilles d'une montre dans la position LÉGÈRE de HI. Quand les lumières de brûleur, enlèvent l'allumeur ou s'assortissent.
4. Si le brûleur ne s'allume pas, enfoncez immédiatement le bouton et tournez le bouton de commande de brûleur à AU LOIN. ATTENDEZ 5 MINUTES avant de répéter les étapes 2 à 4 d'ÉCLAIRAGE MANUEL.

COUPER LE GRIL

Pour couper le gril, enfoncez chaque bouton de commande de valve et tournez-le dans le sens des aiguilles d'une montre à la position de repos.

Fermez toujours la valve à l'offre de gaz après chaque utilisation du barbecue.

AJUSTEMENT DE LA FLAMME

Les boutons sur le visage du barbecue commandent les valves et ajustent la taille de flamme. La première position marquée est éteinte, la deuxième LUMIÈRE de HI, et le troisième BAS. Entre la LUMIÈRE de HI et les BASSES étiquettes sont les mi marques de point. La taille de flamme peut être placée n'importe où entre la LUMIÈRE de HI et les BAS arrangements.

La taille de la flamme avec une valve en BASSE position peut être encore réglée à l'aide d'une petite vis de réglage au centre de la tige de valve. Cette vis est accessible en enlevant le bouton de valve, qui tire immédiatement l'extrémité de la tige de valve.

LIGHTING (IGNITION) INSTRUCTIONS

Read entire instructions before lighting and follow these instructions each time you light the barbecue.

ELECTRONIC LIGHTING

1. Open all lids and remove all covers from the burners you wish to light.
2. Turn all gas control knobs to their **OFF** positions.

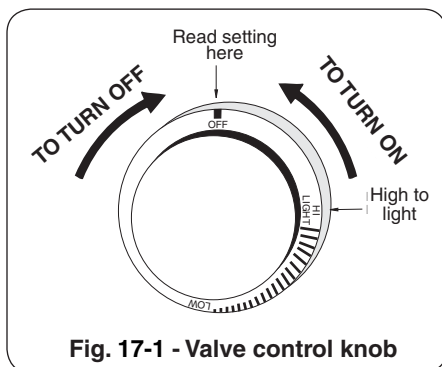

Fig. 17-1 - Valve control knob

Note: No matter which lighting method you use, **DO NOT** turn on the gas to more than one burner at a time. Adjacent barbecue burners will cross-ignite.

3. Turn on the gas at its source.
4. Set the timer control knob (see previous page) to the desired cooking time.

CAUTION: If the burners do not light within 5 seconds, depress the control knob and turn the knob to **OFF**. **WAIT 5 MINUTES** before repeating step 5. If you smell gas follow the instructions on the cover of this manual. If the burners still do not light after several attempts, refer to the **MANUAL LIGHTING** section.

5. Depress the control knob for the burner to be lit and turn it to the **HI LIGHT** position, then press the ignition button. Once the burner lights, release the ignition button.
6. Repeat step 5 for each additional burner to be lit.

Note: Barbecues in some installations achieve a better air/gas mixture and will ignite more quickly if the burner control knob is first turned beyond **HI LIGHT** to **LOW** for lighting.



Fig. 17-3 - Manual lighting

REMEMBER: FOR SAFE MANUAL LIGHTING, PLACE A BURNING MATCH OR BUTANE LIGHTER BESIDE THE BURNER - **THEN TURN ON THE GAS** (see Fig. 17-3).

FOR PROPANE ONLY

Propane tanks are equipped with a safety shut-down device that may cause low or no gas pressure/flame at the burners if operating and lighting instructions are not followed exactly. (See important note in the **TROUBLESHOOTING** section for more details.)

MANUAL LIGHTING

CAUTION: Always wait 5 minutes for gas to clear after any unsuccessful lighting attempt.

1. Follow steps 1 through 4 (left).
2. Insert either a burning long-barrel butane lighter, a burning long-stem match, or a burning match held by a wire extension holder (Fig. 17-2) through the cooking grids to the burner. (Fig. 17-3). For backburners, hold the flame against the perforated material of the backburner. For sideburners, hold the flame against the burner.

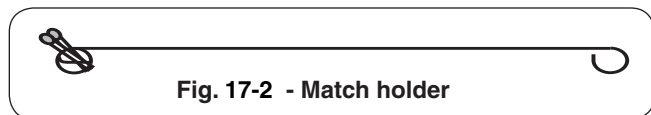

Fig. 17-2 - Match holder

3. While holding the match or lighter flame next to the burner, depress the appropriate burner control knob and turn it counterclockwise to the **HI LIGHT** position. When the burner lights, remove the lighter or match.
4. If the burner does not light, **IMMEDIATELY** depress the knob and turn the burner control knob to **OFF**. **WAIT 5 MINUTES** before repeating steps 2 through 4 of **MANUAL LIGHTING**.

SHUTTING OFF THE GRILL

To shut off the grill, push in each valve control knob and turn it clockwise to the **OFF** position.

Always close the valve to the gas supply after each use of the barbecue.

ADJUSTING THE FLAME

The knobs on the face of the barbecue control the valves and adjust flame height. The first labeled position is **OFF**, the second **HI LIGHT**, and the third **LOW**. In between the **HI LIGHT** and **LOW** labels are mid point marks. Flame height can be set anywhere between the **HI LIGHT** and **LOW** settings.

The height of the flame **with a valve in LOW position** may be further regulated by means of a small adjusting screw in the center of the valve stem. This screw is accessible by removing the valve knob, which pulls straight off the end of the valve stem.

GRILL NOTES PAGE

Please use this page to record any information about your grill that you may want to have at hand.

RIGID SHELF INSTALLATION

This barbecue comes with two rigid shelves that must be attached. These can be attached using the four support screws provided and a Phillips-head screwdriver.

1. Insert the top two screws into the side of the barbecue and screw them in about half way.
2. Line up the larger, bottom portion of the two keyhole openings with the two top screws and fit the two keyhole openings over the two screws. With the shelf pushed all the way against the side of the barbecue, lower the shelf so that the screws lock into the narrower, upper portions of the keyholes.

Note: The shelf will now stay in place on it's own.

3. Insert the bottom two screws into their holes and tighten them all the way.
4. Finally, tighten the upper two screws, completely.

To detach, reverse the process above.

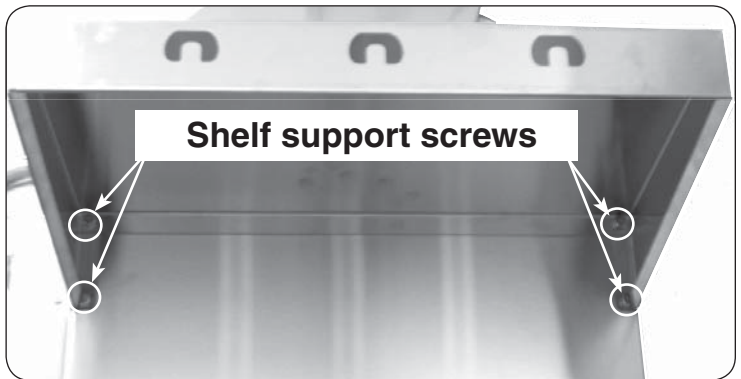

View from under right shelf

ROTISSERIE INSTRUCTIONS (IF EQUIPPED)

USING THE BACKBURNER AND ROTISSERIE

Rotisserie cooking with the backburner is accomplished without use of the main burners. Follow the steps in the appropriate sections below to set up and use these accessories.

SET UP

1. Remove the cooking grids from the barbecue, if necessary, to obtain maximum clearance for larger cuts. The flavor grids may also be removed if required.

Tip: Aluminum foil or a baking pan may be placed over the main burners, a little forward of center, to catch excess drippings from the meat.

2. Attach the rotisserie motor to the rotisserie mounting on the right side of your barbecue by sliding the bracket attached to the motor housing onto the tab on the right of the barbecue so that the spit rod will fit into the motor drive socket from the left.
3. Follow the LIGHTING INSTRUCTIONS to light the backburner.
4. Allow the backburner to preheat for approximately 10 minutes on **HI LIGHT** setting.

PUTTING THE MEAT ON THE SPIT ROD

1. Slide the meat and spit prongs onto the spit rod so the meat is centered and balanced as well as possible.
2. Tighten the spit prongs into place so that the meat remains in a fixed position on the rod and the meat rotates with the rod.

RUNNING THE ROTISSERIE

1. Place the pointed end of the spit rod into the motor drive socket and rest the handle end of the spit rod in the spit bracket on the right side of the barbecue.
2. Plug in (if necessary) and turn on the rotisserie motor.
3. Use a standard roasting guide to estimate the length of time for your meat. A meat thermometer may also be used to tell when your favorite cuts are cooked to your liking. When testing temperatures with a thermometer, turn off the rotisserie motor and turn the backburner on **LOW**. This will keep the meat from over cooking on one side.

Note: When burning properly, the backburner grating will glow red. The first time it is used the backburner may smoke a little.

Important: Operate the backburner with the oven closed. This simulates an oven effect and helps your meat cook faster. Constant rotation of the spit assures even cooking and maximum retention of juices.

Note: On large cuts of meat or whole turkeys, it may be necessary to reduce the heat from your backburner. Cooking food at a lower temperature for a longer period of time will keep the outer surface from burning while cooking the interior of the meat.

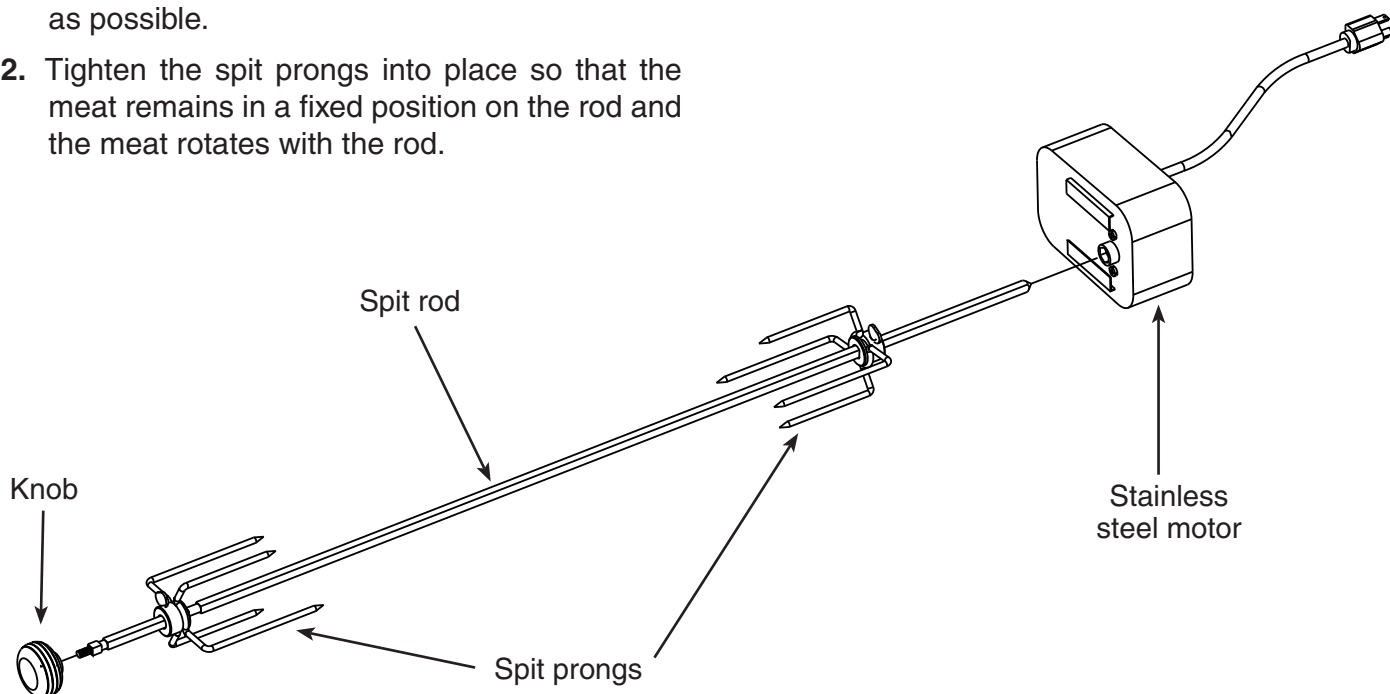

ACCESSORIES

THE VAPORIZER PANEL(S)

Place each vaporizer panel directly on a burner or burner pair. Center each panel over the burner, oriented as shown in Fig. 21-1.

Note: This allows heat from the burners to be evenly distributed throughout the cooking area. The vaporizer panels heat and cool quickly, making the grill very responsive to the changes in heat from the burners.

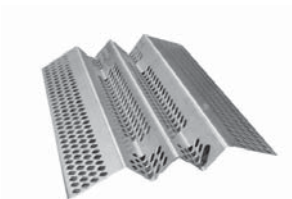

Fig. 21-1

THE DRIP PAN

The drip collection system allows you to brush or scrape excess dried residue from the grilling area directly into the drip pan (see PARTS LIST for drip pan location). To simplify cleanup when using the rotisserie, you may place a baking pan or foil under the rotisserie on top of the burners to collect the drippings. Clean the drip pan after each use.

THE WARMING RACK (if equipped)

The warming rack (Fig. 21-2) is packed separately.

To install the warming rack, lift the front of the rack up slightly and insert the rack hangers into the two holes in the back of the inner oven hood just above the backburner. Then lower the front of the rack into a level position to lock the rack in place.

To remove the warming rack, lift up on the front of the rack until the rack hangers pull free from their supporting holes.

Note: Removing the warming rack before using the rotisserie will leave more clearance for the meat being cooked.



Fig. 21-2 Warming rack in place inside oven

CARE AND CLEANING

FOR SAFETY AND PROPER PERFORMANCE; THIS APPLIANCE MUST BE CLEANED ONCE A MONTH OR MORE FREQUENTLY FROM GREASE BUILD-UP AND OTHER SUBSTANCES.

Stainless steel surfaces when exposed to temperatures produced by the grilling process will change color. The stainless steel will change color from silver to brown and blue. This can be removed by using Fire Magic Stainless Steel Cleaner (3581-1).

Clean your appliance by first using Fire Magic Barbecue and Grill Cleaner (part #3580-1) to remove grease and dirt. Always wipe with the grain (See Fig. 22-1). Next, use Fire Magic Stainless Steel Cleaner (3581-1) to restore the stainless steel color (Note: not for mirror finish). Finish by wiping your appliance down using Fire Magic Polish Wipes (3586-1). To clean the mirror panel, use a quality brand glass cleaner only, not any of the cleaners mentioned above.

Clean your appliance at least once a month.

If your appliance is installed in a seaside (salt air) or poolside (chlorine) location, it will be more susceptible to corrosion and must be maintained/cleaned more frequently. Do not store chemicals (such as chlorine or fertilizer) near your stainless steel appliance.

Due to the nature of stainless steel, surface iron oxide deposits may appear. Do not be alarmed – these deposits are removable with stainless-steel cleaner through prompt and periodic maintenance. If not attended to promptly, permanent pitting may occur.

Check and clean the burner ports and burner carry-over slits for blockage at least annually by removing the burner (see orifice changing instructions) and visually inspecting the burner inlet for insects and nests. A clogged burner can lead to a fire in the bottom of the appliance. (For Fire Magic grills use Maintenance Kit part #MK-1.)

The inside of the appliance may be cleaned periodically with oven cleaner if desired. Follow the oven cleaner instructions for proper use.

Be careful not to get oven cleaner on the outside surface of the appliance as it can permanently damage the finish.

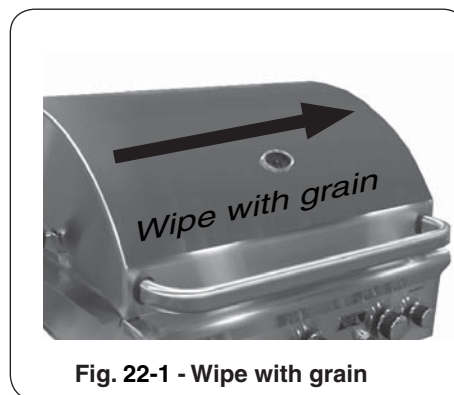

Fig. 22-1 - Wipe with grain

IMPORTANT

IN THE EVENT OF A GREASE FIRE, IMMEDIATELY SHUT OFF THE MAIN GAS VALVE TO THE GRILL. KEEP THE LID OPEN AND ALLOW THE FIRE TO EXTINGUISH ITSELF. A THOROUGH INSPECTION BY A TRAINED SERVICE TECHNICIAN SHOULD BE CONDUCTED BEFORE FUTURE USE OF YOUR GRILL. THE SERVICE TECHNICIAN WILL CHECK THE SYSTEM FOR GAS LEAKS AND WILL CHECK ALL ELECTRICAL WIRING FOR DAMAGE. ALL GAS LEAKS AND WIRING MUST BE REPAIRED PRIOR TO USING YOUR GRILL.

By following these recommendations, you will enjoy the beauty and convenience of your appliance for many years to come.

PROTECTING YOUR APPLIANCE FROM THE WEATHER

An optional heavy-duty cover will protect your appliance's finish and protect your investment. The water repellent cover will protect your appliance from the weather. Always cover your appliance when not in use. (Allow to cool before covering.)

Please specify the model number and serial number of your appliance when ordering a cover.

REPLACING THE IGNITOR BATTERY

1. Remove the ignitor cover by turning it counterclockwise.



Important: Do not attempt to pull or turn the rubber cap.



2. Remove battery for replacement. The battery is reinstalled with the negative (-) end out.



3. After properly inserting the battery, replace the ignitor cover by turning the cap clockwise.



Note: If you have accidentally removed the rubber cap, follow the instructions below to replace it.

1. Pull the rubber cap and the inner plastic sleeve apart.
 2. Carefully insert the rubber cap into over and slide the ignitor cover so inner plastic sleeve it sits behind inner into the cap.
 3. Turn the cap lip.



TROUBLESHOOTING

If you have trouble with the unit, please use this list to identify the problem. By trying one or more of the solutions to the possible cause, you should be able to solve the problem. If this list does not cover your present problem, or if you have other technical difficulties with the unit, please contact your local dealer.

PROBLEM	POSSIBLE CAUSE	CORRECTION
Ignition system failure	1) Improper air shutter adjustment	1) Adjust air shutters.
	2) Ignition wire disconnected	2) Replug wires into generator.
	3) Low gas pressure	3) Adjust or replace battery.
	4) Dead battery	4) Replace battery.
Insufficient heat	5) Improper air shutter adjustment	5) Adjust air shutters.
	6) Using propane orifice for natural gas	6) Change orifices.
	7) Low gas pressure/flame (natural)	7) Have gas company check the operating pressure at the unit.
	8) Low gas pressure/flame (propane)	8) Refill propane tank, or reset propane tank safety*: Shut off all valves (including propane tank) and follow lighting instructions exactly.
Uneven heating	9) Burner ports partially blocked by debris	9) Remove burners and clean out ports.
	10) Small spiders or insects in burner	10) Inspect burners for spider webs or other debris that may block gas flow.
Burner goes out on LOW	11) Valve "Low" setting needs adjustment	11) Light burner on HIGH, immediately turn to LOW setting. Remove knob from valve and using a small flat screwdriver, slowly turn the adjustment screw in the stem, a little at a time (30° to 45°), in either direction, until the flame is approximately 1/4" in height from burner ports.
Rotisserie noisy	12) Rotisserie out of balance	12) Adjust the meat on the spit rod.

Note: *Propane tanks are equipped with a safety shutdown device that may cause low or no gas/flame at the burners if operating and lighting instructions are not followed exactly. If you suspect the propane tank safety shutoff is in effect, shut off all burner control valves and the propane tank valve. Then read and follow the LIGHTING INSTRUCTIONS exactly. Lighting instructions are located in the owner's manual. If the problem persists, continue troubleshooting, or contact your local dealer or distributor for assistance.

AMERICAN OUTDOOR GRILL LIMITED WARRANTY

AMERICAN OUTDOOR GRILL LIMITED WARRANTY

American Outdoor Grill stainless steel burners are warranted for 15 YEARS
All other American Outdoor Grill parts are warranted for 10 YEARS

Except as noted below

American Outdoor Grill ignition systems (excluding batteries), accessories (including sideburners, motors, and thermometers), and vaporizer panels are warranted for one year from the date of purchase.

PLEASE KEEP A COPY OF YOUR SALES SLIP FOR PROOF OF PURCHASE

This warranty applies to the original purchaser and to single family residential use only. It commences from date of purchase, and is valid only with proof of purchase.

This warranty does not cover parts becoming defective through misuse, accidental damage, electrical damage, improper handling, storage, and/or installation. Product must be installed (and gas must be connected) as specified in the instructions or operator's manual, by a **qualified professional installer**. Accessories, parts, valves, remotes, etc., when used must be Peterson Co. product.

This warranty **does not** apply to rust, corrosion, oxidation, or discoloration, unless the affected component becomes inoperable. It **does not** cover labor or labor-related charges.

This warranty specifically excludes liability for **indirect, incidental**, or consequential damages. Some states do not allow the exclusion or limitation of incidental or consequential damages, so the above exclusion may not apply to you. This warranty gives you specified legal rights, and you may have other rights that may vary from state to state.

For additional information regarding this warranty, or to place a warranty claim, contact the R.H. Peterson dealer where the product was purchased.

**TO REGISTER YOUR PRODUCT ONLINE GO TO: WWW.AMERICANOUTDOORGRILL.COM,
AND CLICK ON PRODUCT REGISTRATION. THANK YOU FOR YOUR PURCHASE.**

American Outdoor Grills
14724 Proctor Ave.
City of Industry, CA 91746

ROBERT H. PETERSON CO.

Quality Check

Date: _____

Orifice # (Main): _____

Orifice # (Other): _____

Model #: _____

Leak Test: _____

Serial #: _____

Burn Test: _____

Air Shutter: _____

Gas Type: NAT. / PROPANE

Inspector: _____