

# Fire Magic®

The Ultimate Barbecue

## DELUXE CLASSIC SERIES OUTDOOR GAS BARBECUE 42,000 BTU

For Natural and Propane Gas



**INSTALLER:**

These instructions must be left with the consumer.

**CONSUMER:**

Please retain for future reference.



**FOR FIRE MAGIC BARBECUES: SERIES 61**  
Brick Opening: Depth 17-3/4", Width 24-3/4" Height 12", open front

### INSTALLATION AND OPERATING INSTRUCTIONS

**IMPORTANT:** READ THESE INSTRUCTIONS CAREFULLY BEFORE STARTING INSTALLATION

**FOR YOUR SAFETY  
IF YOU SMELL GAS:**

1. Shut off the gas to the appliance.
2. Extinguish any open flame.
3. Open lid.
4. If odor continues, immediately call your gas supplier or fire department.

**FOR YOUR SAFETY**

1. Do not store or use gasoline or other flammable vapors and liquids in the vicinity of this or any other appliance.
2. A propane cylinder not connected for use shall not be stored in the vicinity of this or any other appliance.

**CODE AND SUPPLY REQUIREMENTS:**

This barbecue must be installed in accordance with local codes and ordinances, or in the absence of local codes, with the latest *National Fuel Gas Code, ANSI Z223.1*, or *CAN/CGA-B149.1, Natural Gas Installation Code* or *CAN/CGA-B149.2, Propane Installation Code*.

This appliance and its individual shutoff valves must be disconnected from the gas supply piping system when testing the system at pressures in excess of 1/2 psig.

This appliance must be isolated from gas supply piping system by closing its individual manual shutoff valves during any pressure testing of gas supply system at pressures up to and including 1/2 psig.

**WARNING:** Improper installation, adjustment, alteration, service or maintenance can cause injury or property damage. Refer to this manual. For assistance or additional information consult qualified, professional installer, service agency or the gas supplier.

**CONTENTS**

<i>Parts List (Exploded view)</i>	Pg. 2
<i>Planning for Installation</i>	Pg. 3
<i>Installing the Barbecue</i>	Pg. 4-5
<i>Use and Care</i>	Pg. 5-7
<i>Adjusting the Barbecue</i>	Pg. 7
<i>Lighting Instructions</i>	Pg. 8

This manual may not be copied, photocopied, reproduced, translated, or published in any electronic or machine-readable form in whole or in part without prior written approval of Robert H. Peterson Co.

**We reserve the right to amend product specifications without prior notice.**

Robert H. Peterson Co. • 14724 East Proctor Avenue, • City of Industry, CA 91746

# FIRE MAGIC DELUXE CLASSIC SERIES GAS BARBECUE PARTS LIST

## TOOLS REQUIRED FOR INSTALLATION

#2 (medium) Phillips screwdriver  
 Two medium size adjustable wrenches or pliers  
 \*3/8" wrench or 3/8" socket screwdriver  
 Pipe joint compound resistant to all gasses  
 \*Note: 3/8" socket if orifice change is required.

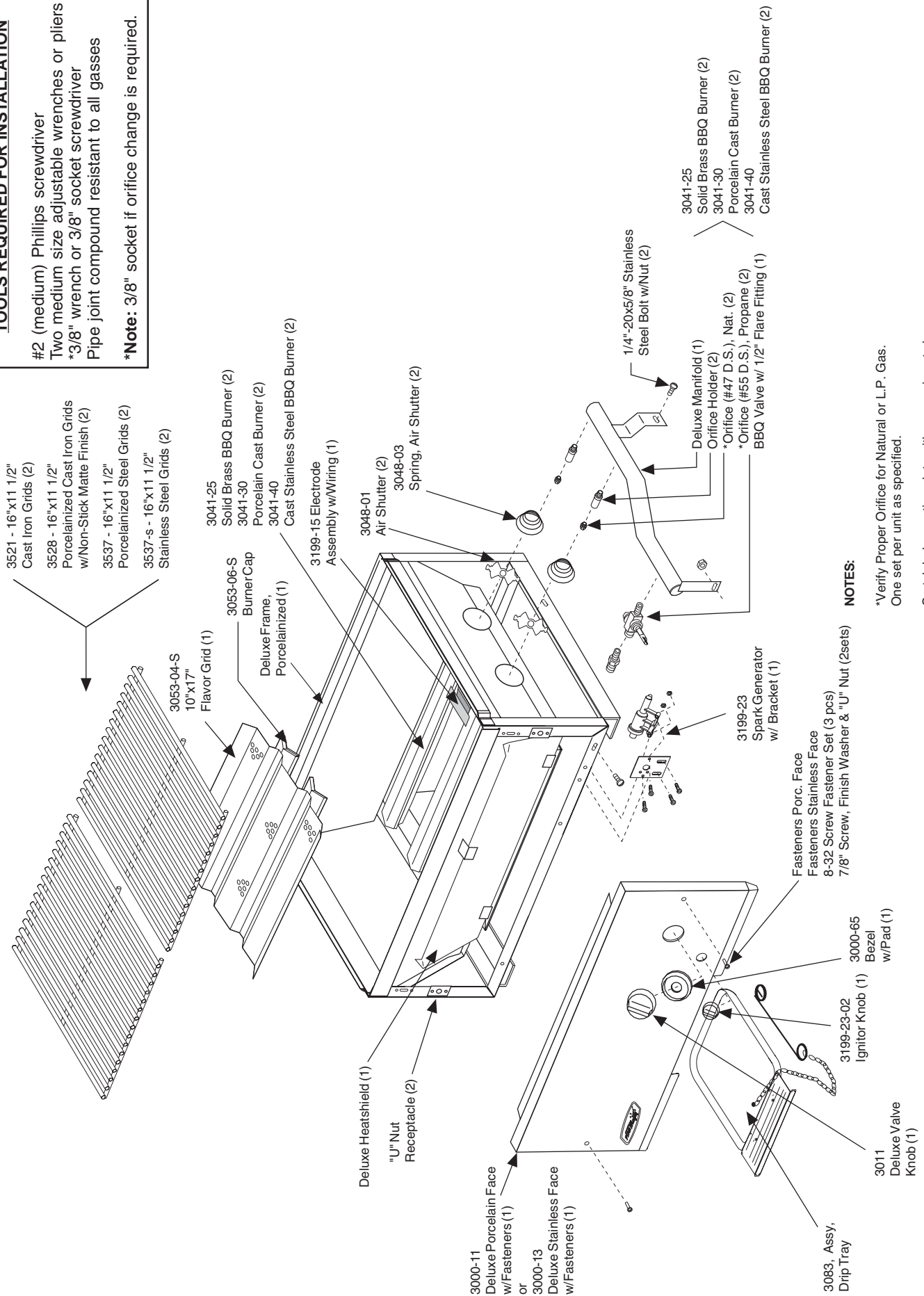

## NOTES:

\*Verify Proper Orifice for Natural or L.P. Gas.  
 One set per unit as specified.

Cert. label mounting plate with screws is not shown.

## PLANNING FOR INSTALLATION OF YOUR DELUXE CLASSIC SERIES BARBECUE

### WHERE TO INSTALL YOUR BARBECUE

Fire Magic Barbecues are for outdoor use only.

**WARNING:** Built-in models must be installed in masonry or other type of fireproof enclosure. The unit is not insulated and therefore must be installed with 18" of side and back clearance from unprotected combustible materials such as wood, plastic or stucco with wood framing.

With our **insulating liner** (Part #3100-50) you can safely install your Fire Magic Barbecue in wood cabinetry or other combustible enclosure.

For easy installation of your Fire Magic Barbecue a **masonry installation hanger** (Part #3100-70 for black finish & 3100-80 for Stainless Steel) is available. It eliminates the requirement for any type of support structure under the barbecue.

Do not install this unit under unprotected flammable surfaces. Do not install or use this appliance inside a building, garage, or any other enclosed area including recreational vehicles or boats.

This is a slide-in type unit designed to fit into open-front enclosures. The front panel (face) of the unit is removable for gas hookup, servicing and burner adjustment. The face must therefore be removable after you install the unit.

**INSTALLER NOTE:** This unit should be installed so that it can be removed at a later date if factory service is required. Any protrusion into the barbecue enclosure may obstruct the frame and prevent the unit from sliding into place (see "Gas Supply Plumbing Requirements", on page 4).

### INSURING PROPER COMBUSTION AIR AND COOLING AIR FLOW

You must maintain proper air flow for your Fire Magic Barbecue to perform as it was designed (Figure 1). If airflow is blocked, overheating and poor combustion will result. Make sure not to block the 1" front air inlet along the bottom of the barbecue face or the air vent openings along the outside-left and right edges of the frame.

**Note:** The 1" front air space allows access to the drip tray.

### VENTILATION OF ENCLOSURES

When using propane gas, take **EXTREME CAUTION** to ensure ample ventilation of gas vapor. Propane vapor is invisible and heavier than air. A **DANGEROUS EXPLOSION** could occur, resulting in **SERIOUS INJURY**, if propane gas is allowed to accumulate and is then ignited.

**Only one cylinder may be stored in an enclosure. Extra or spare cylinders must be stored elsewhere. Read and follow all warnings provided with propane gas cylinders. Never locate a propane cylinder below or adjacent to the barbecue unit unless sufficient ventilation and shielding is provided to prevent any heating of the cylinder, regulator, and rubber hose.**

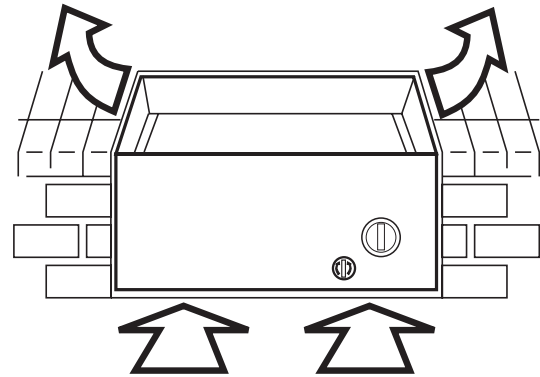

Figure 1 - Ventilation Diagram

### Propane Cylinder Enclosures

To prevent invisible combustible gas from accumulating in your cylinder enclosure, you must provide ventilation. This is accomplished by **EITHER** one side of the gas cylinder enclosure left completely open to the outside **OR** by providing four (4) ventilation openings. Two openings are to be at the cylinder valve level (Approx. 16" above the floor) and at opposite walls of the enclosure. Two more openings must be at the floor level at opposite sides of the enclosure. The floor level openings must start at the floor and shall extend no higher than 5" above the floor. Each opening must have a minimum of 10 square inches (64.5 cm<sup>2</sup>) of free area. To achieve the proper ventilation, you may drill a series of holes, omit the grout from masonry joints or replace a brick with a hardware cloth screen. If the floor in the cabinet is raised and the space beneath the cabinet is open to the outside, the lower ventilation openings may be in the floor.

**FOR YOUR SAFETY**, you must provide these openings for drainage, replacement air and cross ventilation of any storage area exposed to possible leakage from gas connections, the barbecue or propane cylinder.

### HOUSEHOLD PROPANE GAS SERVICE

Consult your gas supplier for ventilation and regulator requirements when connecting to a **HOUSEHOLD** propane supply.

**Note:** Only Fire Magic Barbecue models with the suffix -PA- in the model number are approved by C.S.A. for self contained propane cylinders. Supplemental instructions are supplied with each self contained unit.

**Installer and User Note:** Keep electrical supply cords away from all heated surfaces.

### EXHAUST REMOVAL

If installed under a patio roof, the grill area should be fully covered by a chimney and exhaust hood. An exhaust fan with a rating of 1000 CFM or more may be necessary to efficiently remove smoke and other cooking by-products from the covered area. Installation in fully-enclosed patio areas is not recommended.

## GAS SUPPLY PLUMBING REQUIREMENTS

Rigid 1/2" or 3/4" black steel pipe, or local code approved pipe for temperatures up to 800°F (427°C), is required to conduct the gas supply into the enclosure opening for connection to the unit. **Do not use a rubber hose within the enclosure for the barbecue unit.**

Apply only joint compounds that are resistant to all gasses on all male pipe fittings. Make sure to tighten every joint securely. Do not use pipe joint compound to connect flare fittings.

The gas supply pipe should enter from the rear wall

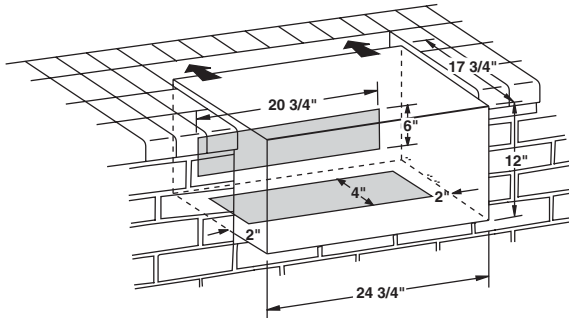

Figure 2 - Gas Stub Diagram

of the enclosure behind the barbecue unit, at least 2" from either side, and between 2" and 8" above the floor as illustrated by the shaded area in Figure 2.

If it is not possible to stub the gas line in from the back of the enclosure, the connection may be made through the floor at the rear of the enclosure. Install the gas line stub at least 2" away from the side and back walls, but within 6" of the back wall as illustrated by the shaded area in Figure 2.

**SAFETY NOTE:** An external valve (with a removable key) in the gas line is necessary for safety when your barbecue is not in use. It also provides for convenient maintenance and repair.

## GAS SUPPLY AND MANIFOLD PRESSURES:

For **Natural Gas** - normal 7" water column, minimum 3 1/2", maximum 10-1/2".

For **Propane Gas** - normal 11" water column, minimum 8", maximum 13".

## INSTALLING YOUR FIRE MAGIC DELUXE CLASSIC SERIES BARBECUE

Perform the following checks before installing your Fire Magic Deluxe Classic Barbecue:

### 1. CHECK FUEL ORIFICES FOR PROPER SIZE

**a.** Your Fire Magic Deluxe Classic Barbecue is equipped with fuel orifices for natural gas, unless otherwise indicated. To use with propane gas, you must install smaller orifices to avoid hazardous overheating. The proper orifice size for **Natural Gas** is **#47** (drill size). The proper orifice size for **Propane Gas** is **#55** (drill size). The size is stamped on the face of the orifice.

**b.** Remove the cooking grills, smoke oven and flavor grid from your barbecue.

**c.** If the gas supply has been connected, make sure the burner valve is in the "OFF" position. Then carefully pull the valve knob and rotary ignition knob from their stems. Use a Phillips screwdriver to turn the face fastener screws counterclockwise to release the face and remove it from the barbecue. Make sure to retain the screws and finish washers until you are ready to reattach the face.

**d.** Using a flat blade screwdriver, pry the burner retaining clip from rear wall of the barbecue frame (see Figure 4). Remove the burner by; A) Pulling it to the front of the barbecue, B) Lift the far end out of the notch, C) Pull the burner away from the manifold, taking care not to lose air shutter and spring, which may become detached when the burner is removed.

### 2. POSITION THE BURNERS FOR OPERATION

**a.** After checking orifice drill size install the air shutter spring and the air shutter over the orifice holder fitting, between the burner and the pipe manifold, in the order and position shown in Figure 3.

**b.** Replace the burners in the holding groove, ensuring that the brass orifice and orifice holder fittings project deeply into the burners. Replace the burner retaining clips.

### 3. CONNECT THE GAS SUPPLY TO YOUR FIRE MAGIC DELUXE CLASSIC SERIES BARBECUE

**a.** You will need an CSA approved stainless steel flex connector to bring the gas supply from the gas line stub to the valve manifold. A 1/2" x 36" or 48" flex connector with 1/2" flare to 1/2" pipe adapter on one end, and a 1/2" flare female fitting on the other end is suitable for most installations.

**CAUTION: Use only stainless steel flex connectors that are C.S.A. listed. A rubber or plastic connector will rupture or leak, resulting in an explosion or serious injury if used inside the barbecue enclosure.**

**b.** Make sure that your gas supply is turned 'OFF'. Then connect the 1/2" pipe adapter fitting supplied with the stainless steel flex connector to the gas supply stub. Use pipe joint compound that is resistant to all gasses on the male pipe fitting and tighten securely. Do not use pipe joint compound to connect the flare fittings.

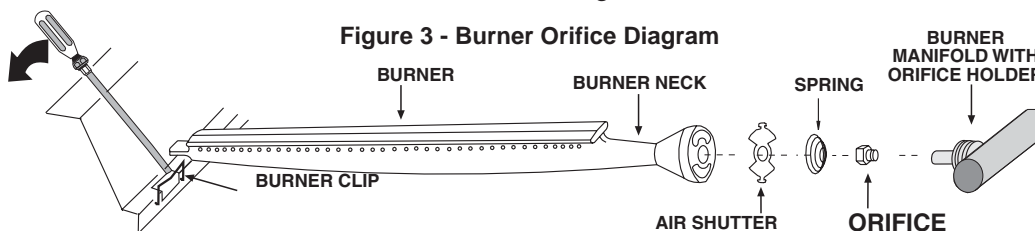

Figure 3 - Burner Orifice Diagram

## CONNECTING THE GAS SUPPLY (Continued)

c. Slide your barbecue into place, making sure not to pinch or kink the gas connector.

d. Bring the flex connector around the left-hand side of the barbecue. Use the locator angle brackets on the left lower-frame to position the flex connector. Continue the flex connector around the front of the unit to the valve inlet flare fitting. Be careful not to block the 1" front vent opening as this will obstruct drip tray removal.

e. Connect the flex connector to the flare fitting on the valve. Support the valve inlet fitting with a wrench to avoid applying excessive torque to the valve body while tightening this connection securely. Do not use pipe compound on flare fittings.

f. Make sure the barbecue burner valve is in the 'OFF' position. Turn the gas supply on. Then carefully check all gas connections for leaks with a brush and soapy water before lighting. NEVER USE A MATCH OR OPEN FLAME TO TEST FOR LEAKS.

g. Refer to the 'Air Shutter Adjustment' and 'Lighting Instructions' on pages 7 and 8 of this manual before replacing barbecue face and knobs.

### 4. INSTALL THE FLAVOR GRID

a. Place the flavor grids directly on the burners, centering the grids over the burners with the open side up (Figure 4). This allows heat from the burners to be evenly distributed throughout the cooking area.

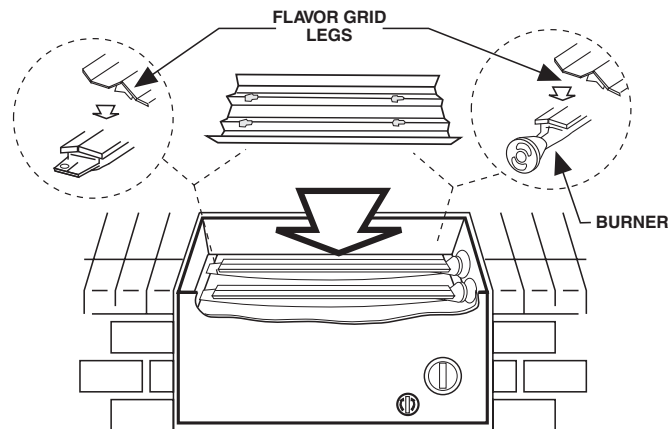

Figure 4 - Flavor Grid Diagram

The flavor grid heats and cools quickly, making your Fire Magic Barbecue very responsive to the changes you specify in grill temperature.

The flavor grid is made of 304 stainless steel. It is rust resistant and may be cleaned with standard oven cleaners.

### 5. DRIP COLLECTION SYSTEM

The drip collector in this Fire Magic Barbecue is part of the unit's main frame, and is located below the burners. The drip collector has holes which allow excess drippings to fall through during cooking. The drip collector is also useful as it allows you to brush or scrape off excess dried residue inside the barbecue directly into the drip tray.

## USE AND CARE OF YOUR FIRE MAGIC BARBECUE

### SAFETY INFORMATION

Every time you use your barbecue, make sure that:

1. The area around the barbecue is clear of flammable substances such as gasoline, yard debris, wood, etc.
2. There is no blockage of the air flow through the vent space located below the face of the unit.
3. When using propane gas, the special ventilation openings in the enclosure must be kept free and clear of debris.
4. The burner flames burn evenly along both sides of each burner with a steady flame (mostly blue with yellow tipping). See the 'Lighting Instructions' on page 8 of this manual for more information.
5. The drip collector holes are clear and unobstructed. Failure to remove excessive grease deposits accumulated in either the drip collector or the drip tray below can result in a grease fire.
6. The in-line gas valve or tank (cylinder) valve is always shut-off when the barbecue is not in use.

### PREPARING THE BARBECUE FOR COOKING

To extend the life of your Fire Magic Barbecue, follow these steps prior to cooking:

1. Begin by heating the unit at a normal cooking temperature for several minutes.
2. Then open the control valve to the 'HIGH' setting to burn off residue remaining from prior use.
3. When the barbecue has heated sufficiently, set heat to the desired cooking level.
4. When using a smoke oven, closing the cover during the preheat period will accelerate the preparation process. Do not operate unattended at high flame as cooking temperatures will quickly be exceeded.

### WARNING:

Never cover the *entire* cooking or grill surface with griddles or pans. Overheating will occur and burners will not perform properly when combustion heat is trapped below the cooking surface.

## USE AND CARE OF YOUR BARBECUE

### FLAVOR FROM WOOD CHIPS OR CHARCOAL

Convenient **Fire Magic Gourmet Grilling Chips** are sold in several different popular wood types. These chips are pre-moistened and sealed in cans which can be opened, by lifting the tabbed lid, before placing the entire can on the flavor grid to add natural wood smoke flavor to the food you grill. There is no mess to clean up. Just discard the can of ashes after there is no longer any wood smoke aroma.

You may also add wood chips, wood chunks or the natural wood charcoal of your choice to the flavor grid. We recommend placing wood outside the direct cooking zone or wrapping it in perforated aluminum foil. Soaking wood before use will slow burning and increase smoke flavor. Wood and charcoal ash will remain in the flavor grid after use. The grid can be easily removed and cleaned when the unit has fully cooled.

### CARE OF STAINLESS STEEL COMPONENTS

If your barbecue has a stainless steel oven or front panel, the following care instructions will keep your unit looking and working like new. Stainless steel components are constructed of the finest prime grade type 304 stainless steel. Meticulous attention has been given to maintaining the attractive finish throughout the manufacturing process. Like the stainless steel used in commercial kitchens, your barbecue requires regular cleaning and occasional buffing to maintain its bright, clean appearance.

Deposits of dirt and grease can be removed easily with **Fire Magic Foaming Barbecue and Grill Cleaner**. Deposits should be removed before they are allowed to bake onto the finish. To remove more stubborn deposits, use a scouring pad recommended for stainless steel. Be sure to always rub in the direction of the polishing lines (Figure 5).

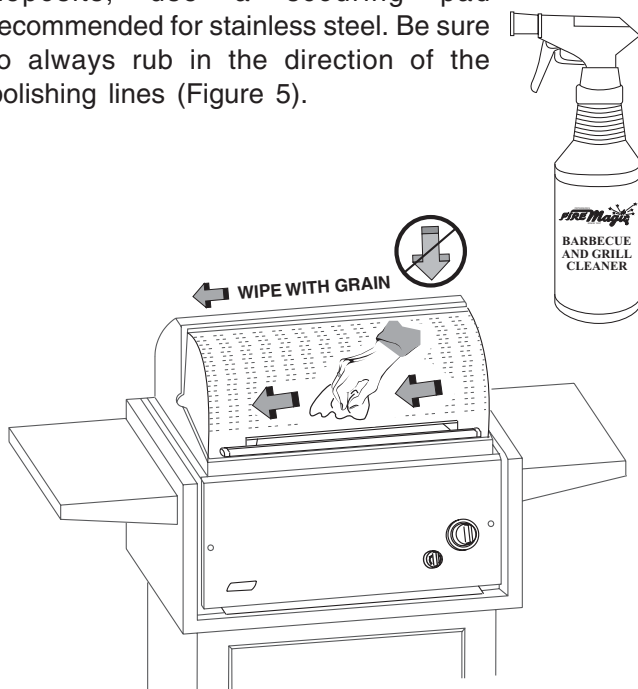

Figure 5 - Always rub with the grain

Oven cleaner may be used, according to manufacturer's instructions, to remove cooked-on food deposits. Special cleaning agents and polishing pads recommended for stainless steel are available at your local barbecue dealer, hardware store or supermarket.

**CAUTION:** Never use ordinary steel wool or steel brushes on stainless steel. Tiny particles left behind may rust and stain the finish. Abrasive pads recommended for restoring the grain in stainless steel will, over a period of time, scratch or dull the surface of glass or porcelain-coated products.

### CLEANING YOUR BARBECUE

The frame liner and many front panels (faces) of Fire Magic Barbecues are porcelainized to provide many years of trouble-free service. These surfaces may be cleaned with Fire Magic Foaming Barbecue and Grill Cleaner or with oven cleaner, following manufacturer's instructions.

### CARE OF COOKING GRIDS

If your Fire Magic Barbecue has porcelain-coated or stainless steel cooking grids, the following care instructions will keep them looking and performing like new.

Stainless steel rod grids, high temperature porcelainized rod or our special high temperature porcelainized matte (satin) finished cast iron cooking grids, will give you years of corrosion-free service.

We recommend that you spray a light coat of vegetable oil on your cooking grids and then brush them lightly with a cleaning pad or a brass wire grill brush before and after use to insure maximum life and insure their cooking readiness.

**CAUTION:** Never use acid chemicals to clean porcelain surfaces.

### CARE OF UNCOATED CAST IRON COOKING GRIDS

All uncoated cast iron will rust if not properly seasoned. Please read and follow the seasoning instructions below to ensure long life and proper performance.

The special qualities of properly seasoned cast iron cooking grids (quick, even heating, sustained heat retention, nonstick cooking and excellent searing capabilities) make them the preferred choice of master chefs. Only an uncoated cast iron cooking surface that's been properly treated and maintained can offer these qualities.

Your Fire Magic Cast-Iron Cooking Grids are heavier with the bars closer spaced than most other grids, retaining maximum temperatures even when suddenly covered with cold meat. Because of this, they sear in the natural juices so you can enjoy the full flavor of your favorite cuts.

## USE AND CARE OF YOUR BARBECUE

### SEASONING YOUR CAST IRON GRIDS

**Initial Seasoning:** Wash the cooking grids thoroughly with a mild detergent and scrub brush, rinse and dry. Saturate the cast iron surfaces with a high-quality vegetable cooking oil. The grids can be immersed, or the oil thoroughly worked into the cast iron by brushing and/or swabbing. Allow the oil to run off or drain, then bake the grids in the barbecue oven at a low (275° to 325°) temperature for two to three hours. Re-oil and wipe off the excess with a clean rag or paper towel. Your cast iron grids are now ready for use.

### USE AND MAINTENANCE

For best cooking performance, the wide side of the cooking grid bars should be face up. After each use, brush off any residue, preferably while the grids are still warm. A brass wire brush is ideal. Apply vegetable oil with a clean cloth or spray can. Brush in and wipe clean with a rag or clean paper towel. Your cast iron grids are now ready for their next nonstick cooking performance.

Occasionally turn grids over and brush off accumulated residue that could ignite during high temperature cooking. Cooking food particles off the grids at high temperatures for extended periods, may

dry out the cast iron and make it more susceptible to rusting. If grids do become overheated and dry out, repeat the initial seasoning procedure. Rust can be prevented by keeping your grids properly seasoned. Wrap the grids in newspaper or paper towels and store them in a dry place if you are not planning to use them for several weeks.

### BURNER MAINTENANCE

Fire Magic Burners are constructed of heavy-duty, high-quality porcelain coated cast iron, cast stainless steel or cast brass and will withstand many years of outdoor use, if the following ordinary precautions are taken: Once or twice a year inspect the burners and determine if scale is building up excessively. Burners can be removed and scraped to remove debris or scale from the ports. Spray burners with vegetable oil occasionally to inhibit oxidation. Replace burners immediately if they show any signs of weak or thin walls. Refer to page 4 for reinstalling burners.

### CAUTION:

**Never spray water on a hot gas unit as this may damage porcelain or cast iron components.**

## ADJUSTING YOUR BARBECUE

**IMPORTANT: This barbecue will not light and will not heat evenly or cook properly unless the air shutters are adjusted following installation (reference "Air Shutter Adjustment", below).**

Burner air shutters are accessed by removing the front panel (face). The air shutters are located at the end of the burners on the right side of the unit (see page 2). The air shutter has a small dimple (see Figure 6A), which allows it to lock into notches in the burner face. This prevents the air shutter from moving. Close the air shutters by turning the tabs to a vertical position (Figure 6B). The air shutters on Deluxe Barbecues can be adjusted by using the match holder (provided with each unit - Figure 8, page 8). Place the ring over the air shutter tab and push or pull to adjust the opening. Close the air shutters with the tabs pointing up and down (Figure 6B). Light your barbecue in accordance with the manual lighting instructions found on page 8 and burn for 5 minutes with the burners on 'HIGH' and the oven open.

### AIR SHUTTER ADJUSTMENT

After burning for 5 minutes, open the air shutters until the flames lift off, or appear not to be touching the burners. Then begin closing the air shutters until the flames appear to burn while touching the burner ports (Figure 6B). You may then see short yellow tips on

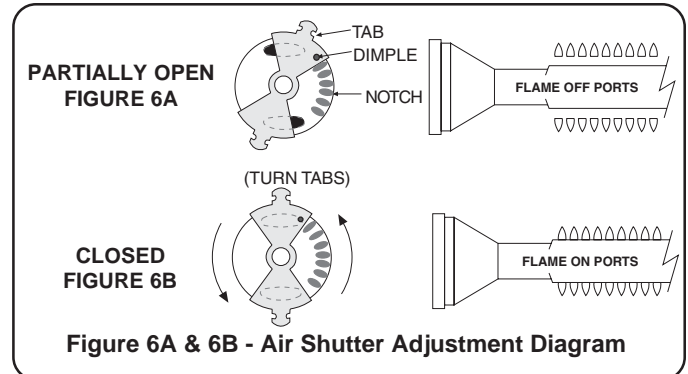

the flames. If flames are a lazy yellow, open the air shutters until the flame is blue with yellow tipping.

### ADJUSTING THE FLAME HEIGHT

The large knob on the face of the barbecue controls the valve and adjusts flame height. The first position is 'HIGH', the second 'MEDIUM' and the final 'LOW'. flame height can also be set anywhere between the High, Medium, and Low settings for all cooking requirements and tastes.

Height of the flame with the **valve in low position** may be regulated by means of a small adjusting screw in the center of the valve stem. This screw is accessible by removing the plastic valve knob which pulls straight off the end of the valve stem.

## LIGHTING INSTRUCTIONS

Follow these instructions each time you light your Fire Magic Barbecue.

### FOR AUTOMATIC LIGHTING:

1. Read these instructions before lighting.
2. Open the lid of the smoke oven.
3. Turn both barbecue gas valves to the 'OFF' position.
4. Turn on the gas at the source outside of the barbecue enclosure.
5. Push the gas valve and turn to 'HIGH' then immediately turn the light knob several times in the direction of the arrows.

**CAUTION:** If the burners do not light, IMMEDIATELY turn the valve to "OFF" and WAIT 5 MINUTES before repeating step 5. If the burners still do not light, refer to the instructions below for manual lighting.

**Note:** Barbecues in some installations achieve a better air/gas mixture and **will ignite more quickly** if the valve is first turned beyond High to Medium or Low for lighting.

### FOR MANUAL LIGHTING:

**CAUTION:** Always wait 5 minutes for gas to clear after any unsuccessful lighting attempt.

1. Follow steps 1 through 4 above.
2. Insert either a burning long-barrel butane lighter, a burning long-stem match or a burning match held by a wire extension holder through the cooking grids to the burners below the flavor grid.
3. While holding the match or lighter flame next to the burner, depress the valve knob and turn it counterclockwise to the 'HIGH' position. Adjacent burners will cross-ignite.
4. If the burner does not light, IMMEDIATELY turn the valve to 'OFF' and WAIT 5 MINUTES before repeating steps 2 through 4 of the manual lighting instructions.

*Replacement parts may be obtained from your nearest Fire Magic Dealer. For assistance in locating a dealer, please contact our factory at the address listed below.*

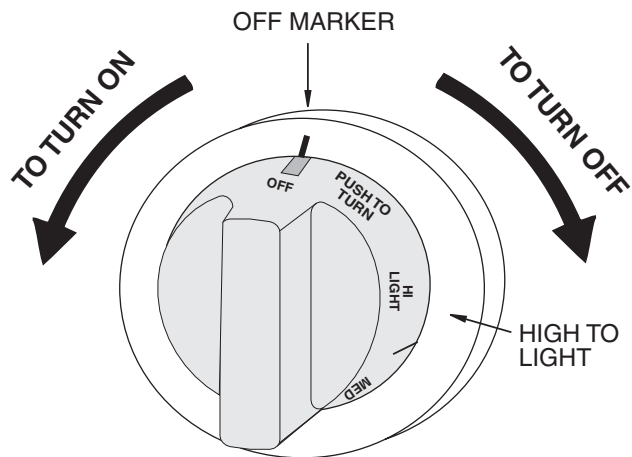

Figure 7 - Valve Control Knob



Figure 8 - Match Holder

**REMEMBER:** FOR SAFE MANUAL LIGHTING, PLACE A BURNING MATCH OR BUTANE LIGHTER BESIDE THE BURNER - THEN TURN ON THE GAS (Figure 9).

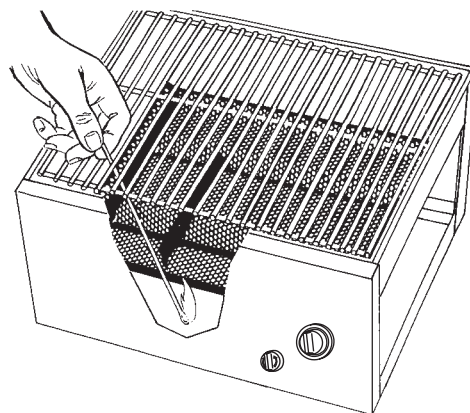

Figure 9 - Manual Lighting

### IF YOU SMELL GAS

1. Shut off gas to the appliance.
2. Extinguish any open flame.
3. Open lid if equipped with oven.
4. If the odor continues, immediately call your gas supplier or fire department.

## ROBERT H. PETERSON CO.

Quality Check \_\_\_\_\_

Date: \_\_\_\_\_

Orifice # (MAIN): \_\_\_\_\_

Orifice # (OTHER): \_\_\_\_\_

Model #: \_\_\_\_\_

Leak Test: \_\_\_\_\_

Serial #: \_\_\_\_\_

Burn Test: \_\_\_\_\_

Air Shutter: \_\_\_\_\_

Gas Type: NAT / PROPANE

Inspector: \_\_\_\_\_