

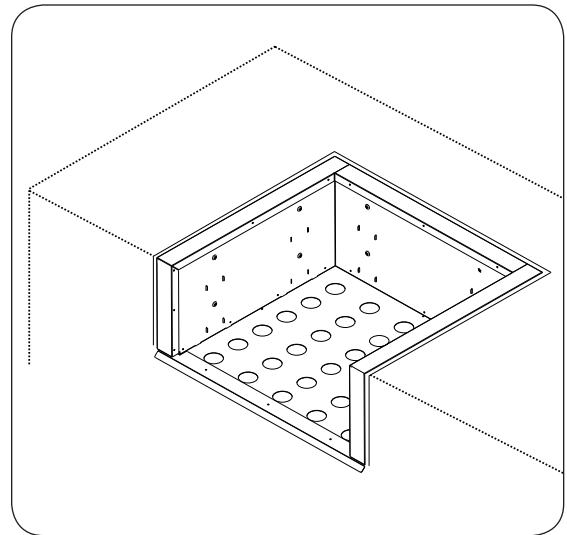

AURORA INSULATING LINER INSTRUCTIONS

INSTALLER: Leave these instructions with consumer.
CONSUMER: Retain for future reference.



IMPORTANT INFORMATION & TECHNICAL DATA

Read these instructions and the safety and installation portions of the grill instructions before liner installation.

The insulating liner kit includes the pre-assembled liner, two support hangers, and a heat shield. Liner cutout dimensions are given in Table 1. A nominal $\frac{1}{16}$ " gap around the back and sides of the liner is recommended for ease of installation. A minimum of 5" from combustible material is required directly below the top of the support hangers/Stud A, to allow for clearance of the heat shield (See Fig. 2-2). If a complete combustible shelf is installed beneath the heatshield, it must contain two ventilation cutouts. The cutouts must be located directly below the right hand and left hand ends of the heatshield. Reference Table 2 for dimensions. If the countertop thickness exceeds 2", new screw holes must be made in the support hangers.

Countertops and cabinet faces made of combustible material, such as wood, Formica, and Corian, can extend up against the outside walls of the insulating liner and be joined by a bead of silicone sealer rated for 400° or higher, as shown in Fig. 3-1. Never build over the insulating liner with combustible materials, as this will interfere with the grill hanger.

The cabinet base must include 100 sq. in. of ventilation within 12" of the floor. Refer to the grill safety precautions and installation instructions for additional propane gas venting requirements (if applicable).

Replacement parts may be obtained from your nearest Robert H. Peterson Co. dealer. For assistance in locating a dealer, you may contact the factory at the address listed below.

Grill Series	Liner Model	Height	Width	Depth
A430i	23130-50	12"	30 $\frac{1}{8}$ "	22 $\frac{1}{8}$ "
A530i	23125-50	12"	30 $\frac{1}{8}$ "	26"
A540i	23150-50	12"	36 $\frac{5}{8}$ "	22 $\frac{1}{8}$ "
A660i	3176-50	12"	36 $\frac{3}{8}$ "	26"
A790i	3186-50	12"	42 $\frac{1}{8}$ "	26"

Table 1 - Enclosure cutout dimensions (for liner)

Grill Series	Width	Depth
A430i	4 $\frac{1}{4}$ "	13 $\frac{3}{4}$ "
A530i	4 $\frac{1}{4}$ "	16 $\frac{3}{4}$ "
A540i	4 $\frac{1}{4}$ "	13 $\frac{3}{4}$ "
A660i	4 $\frac{1}{4}$ "	16 $\frac{3}{4}$ "
A790i	4 $\frac{1}{4}$ "	16 $\frac{3}{4}$ "

Table 2 - Combustible shelf cutout dimensions

ROBERT H. PETERSON CO. • 14724 East Proctor Avenue, City of Industry, CA 91746

IMPORTANT INFORMATION & TECHNICAL DATA (cont.)

Model	Front (X) †	Rear (Y) †
A430i	4"	15 1/2"
A530i	4"	18 1/2"
A540i	4"	15 1/2"
A660i	4"	18 1/2"
A790i	4"	18 1/2"

† See Fig. 2-1 for hanger setback detail

Table 3 - Hanger setback dimensions

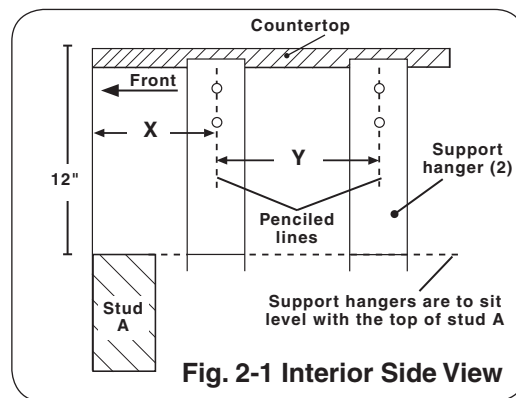

Fig. 2-1 Interior Side View

INSTALLATION

Note: Additional framing may be necessary to properly anchor the support hangers.

Step 1: On the inside of the grill opening, pencil in a vertical line X" from the front of the enclosure. Then, pencil in a second line, Y" (back) from the first line. **(See Table 1 and Fig. 2-1 for dimensions)**. Do the same on the opposite side as well.

Note: The distance between lines 1 and 2 must be Y" to allow for proper alignment and installation of the heat shield with the support hangers (see Fig. 2-1 & Fig. 2-2).

Step 2: Align the top of the support hangers level and flush with the opening 12" down from the countertop (i.e., the top of stud A). Line up hanger holes with your penciled lines (see Fig. 2-1 & Fig. 2-2) and screw into position.

Step 3: Bend the 4 heatshield tabs upward, slightly less than a right angle, approximately 85°. Insert the tabs into the slots located at the bottom of the two support hangers. Once inserted they will slightly flex outward and lock in position. (See Fig. 2-3.)

Step 4: Install the insulating liner as shown in Fig. 3-1. **Top of liner must be flush with countertop.**

Note: Drawings not to scale. Reference Table 1 and Table 3 for dimensions.

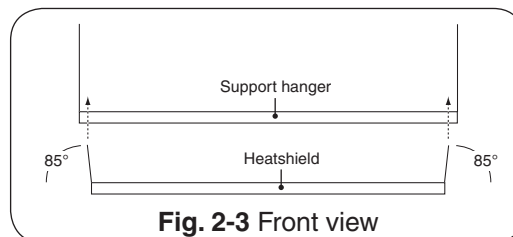
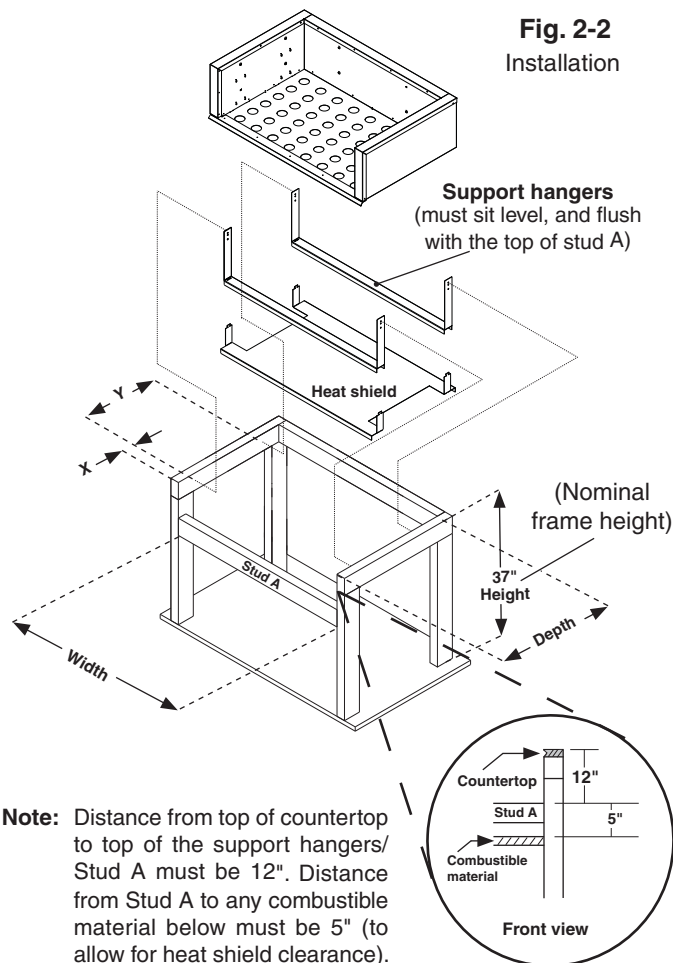

Fig. 2-3 Front view

INSTALLATION (cont.)

Refer to the grill safety precautions and installation instructions to install the grill.

DO NOT ALLOW THE GRILL HANGER TO COME IN CONTACT WITH THE COUNTERTOP OR ANY COMBUSTIBLE SURFACE (Fig. 3-2).

Replacement parts may be obtained from your nearest Robert H. Peterson Co. dealer. For assistance in locating a dealer, you may contact the factory at the address listed below.

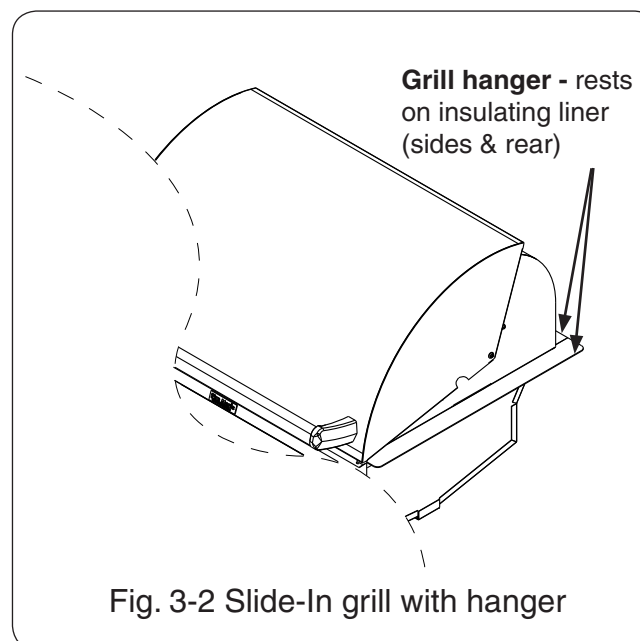
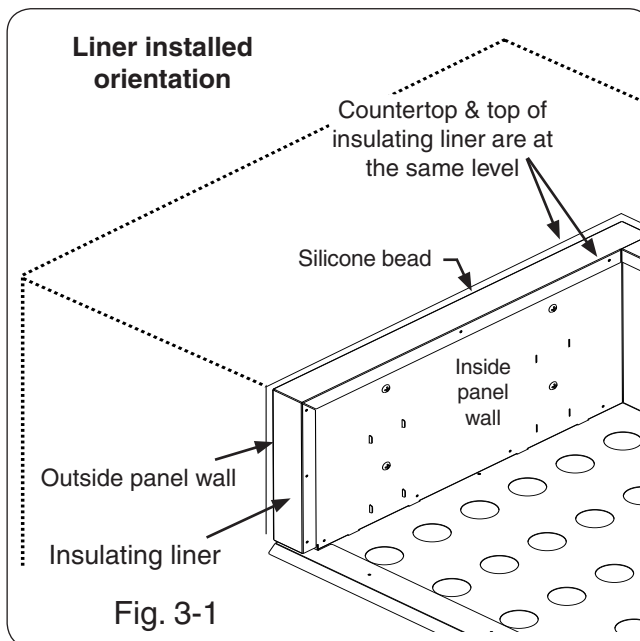

NOTES PAGE

Please use this page to record any information about your liner that you may want to have at hand.