

FIREMAGIC

CUSTOM IN-GROUND POST CHARCOAL GRILL

INSTALLATION AND OPERATING INSTRUCTIONS

INSTALLER: Leave these instructions with consumer.

CONSUMER: Retain for future reference.



IMPORTANT: READ THESE INSTRUCTIONS CAREFULLY BEFORE STARTING INSTALLATION OR USE.

SAFETY WARNINGS & CODES

▲ WARNING

1. Do not store or use gasoline or other flammable vapors and liquids, including propane cylinders, in the vicinity of this or any other appliance.

▲ WARNING

Improper installation, adjustment, alteration, service, or maintenance can cause injury or property damage. Refer to this manual. For assistance or additional information, consult a qualified professional installer, or service agency.

CODE REQUIREMENTS: This grill must be installed in accordance with local codes and ordinances.

WARNING: All surfaces of the charcoal unit become **HOT** during use. Exercise caution when using this unit, especially when adding charcoal or cranking the charcoal pan up or down.

TABLE OF CONTENTS

SAFETY WARNINGS & CODES	1
PARTS LIST	2
PLANNING THE LOCATION OF YOUR POST GRILL	2
EXHAUST REMOVAL	2
INSTALLATION AND SETUP	3
INSTALLATION	3
ATTACHING THE IN-GROUND POST EXTENSION	3
IN-GROUND PROCEDURE	3
ASSEMBLY	3
RIGID SHELF ASSEMBLY	4
OPERATION	4
USING YOUR CHARCOAL GRILL	4
ACCESSORIES	5
WARMING RACK	5
AIR SHUTTERS	5
CHARCOAL PROTECTOR	5
DRIP TRAY SPACER	5
CLEANING	5
USING THE GRILL BRUSH	5
USING THE COOKING GRID LIFTER	5
FIRE MAGIC® STAINLESS-STEEL CHARCOAL GRILL LIMITED WARRANTY	6

Robert H. Peterson Co. • 14724 East Proctor Avenue • City of Industry, CA 91746

PARTS LIST

Item	Description
1.	Custom, smoking oven Lift-A-Fire (LAF)
2.	Shelf, rigid (2)
3.	Frame, charcoal Custom portable
4.	Face, Custom LAF assembly
5.	Drip tray, plate Custom
6.	Custom, drip tray LAF assembly
7.	Custom, pedestal base
8.	In-ground post, charcoal (weld) assembly
9.	In-ground post, extension (weld) assembly
10.	Screw, 1/4-20 x .625 trss ph
11.	Plate, pan Custom LAF

IMPORTANT
 This Fire Magic® grill is pre-assembled and tested at the factory.
The plastic straps that secure the oven to the grill unit must be removed and discarded prior to lighting.

Replacement parts can be ordered from your local Fire Magic® dealer.

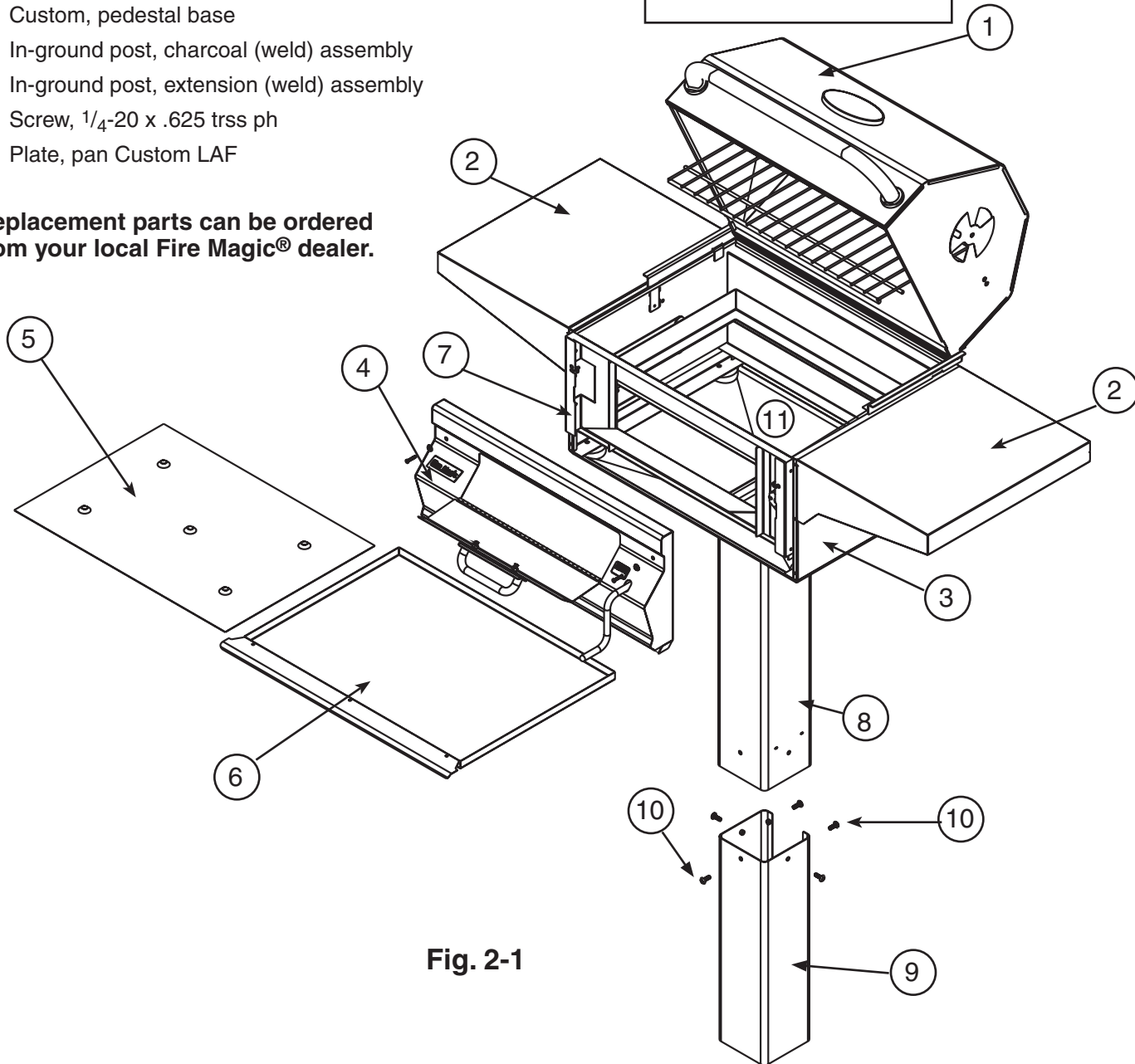

Fig. 2-1

PLANNING THE LOCATION OF YOUR POST GRILL

This grill is designed **FOR OUTDOOR USE ONLY.**

DO NOT use this unit under unprotected flammable surfaces. DO NOT use this appliance inside a building, garage, or any other enclosed area. It must not be used in or on recreational vehicles or boats.

Important: This unit is NOT insulated; therefore, during use it must be located with a minimum of 18" of side and back clearance from unprotected combustible materials, such as wood, plastic, or stucco with wood framing.

EXHAUST REMOVAL

If installed or used under a patio roof, the cooking grid area should be fully covered by a chimney and exhaust hood. An exhaust fan with a rating of 1,000 CFM (cubic feet per minute) or more may be necessary to efficiently remove smoke and other cooking by-products from the covered area. **THIS UNIT SHOULD NOT BE LOCATED IN A FULLY ENCLOSED AREA OF ANY KIND.**

INSTALLATION AND SETUP

INSTALLATION

CAUTION: Metal edges are sharp. Use adequate hand protection, such as gloves, when assembling and configuring the grill.

ATTACHING THE IN-GROUND POST EXTENSION

1. Attach the extension to the bottom of the grill post so that the open portion is toward the back of the grill and the five (5) holes in the extension line up with the five (5) weld-nuts in the post.
2. From outside the joined post and extension, insert one of the $\frac{1}{4}$ x $20\text{-}\frac{5}{8}$ " bolts (supplied) into each of the five (5) bolt holes and tighten each using a $\frac{7}{16}$ " socket driver or wrench (see Fig. 3-1).

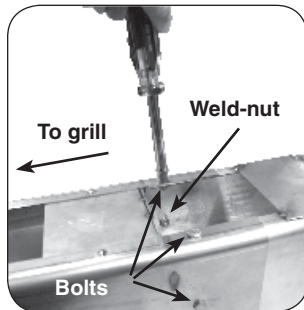

Fig. 3-1

Note: There is one (1) hole on each side of the post, except the back, which has two (2) holes located on either side of the extension opening.

IN-GROUND PROCEDURE

Read instructions carefully all the way through before beginning the installation.

1. Dig a hole for the post and extension approximately 18" deep and 10-12" in diameter.

Note: The actual depth of the hole should be such that the cooking surface is 36" above ground level.

2. Pour the concrete into the hole approximately 3-5" below ground level.

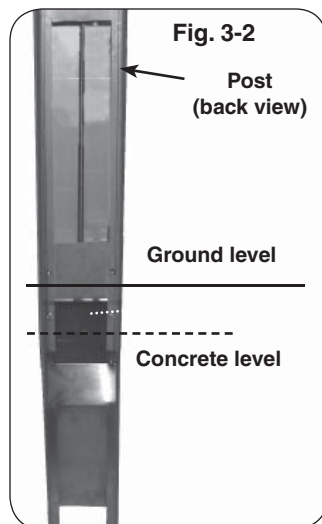

3. While the concrete is still wet, carefully lower the grill post and attached extension into the hole.
4. Orient the grill per plan, then level the grill and support it so that it remains in position while the concrete dries.

ASSEMBLY

Carefully unpack your grill and check the parts.

1. Locate the crank handle (Fig. 3-3) packed inside the grill enclosure.
2. Open the door in the front panel as shown in Fig. 3-3. Insert the threaded end into the crank handle through the hole on the right of the grill face and into the nut on the frame as shown.
3. Center the crank on the nut and begin cranking in a clockwise direction until the threads have properly caught hold.
4. Close the door in the front panel and continue cranking until the lifter begins to move upward inside the grill.

Note: The access door must be closed for the crank to raise the lifter to the highest position.

5. Place both cooking grids with cut-outs toward the front, as shown in Fig. 3-4.

6. Install both shelves as indicated on the following page.

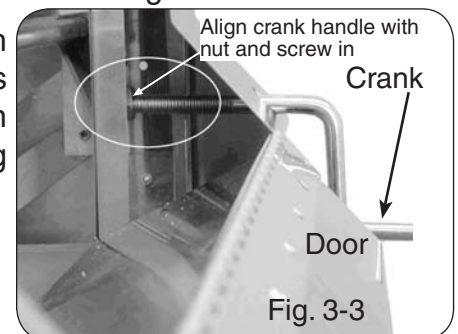

Fig. 3-3

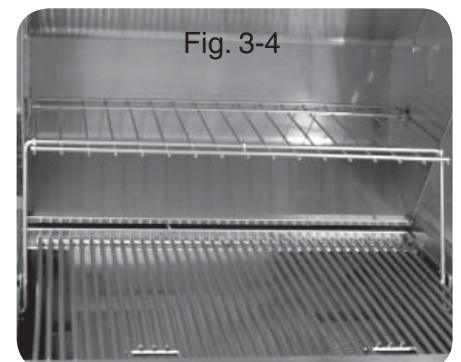

Fig. 3-4

RIGID SHELF ASSEMBLY

This grill comes with two (2) rigid shelves that must be attached. These can be attached using the four (4) support screws provided and a long Phillips-head screwdriver.

1. Hold the shelf inverted so that one of the corner holes in the shelf lines up with the appropriate upper screw hole in the grill.
2. Insert the screw (but do not tighten all the way) so that the shelf can be easily rotated around the first screw.
3. Line up the second corner hole in the shelf with the remaining upper screw hole in the grill. Insert a screw and tighten.

Note: You may lift the edge of the shelf upward to gain better access during much of the tightening of this screw.

4. Finally, insert the bottom screws on the left and right side of the shelf and securely tighten all screws.

Detaching is the reverse process of above.

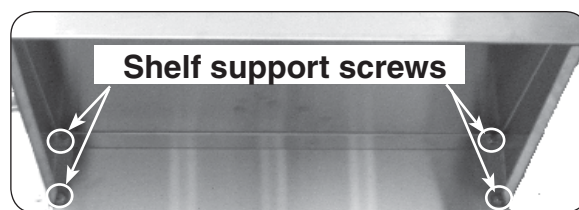

View from under right shelf

Fig. 4-3

OPERATION

Simple to use, this elegant stainless-steel charcoal grill has the added benefit of an adjustable charcoal pan to allow you to change the height of the charcoal while cooking, and gives you the ability to add fuel without having to remove the cooking grids. This enables the outdoor chef to be in complete control of the cooking heat at the grilling surface.

USING YOUR CHARCOAL GRILL

1. Remove the cooking grids and pile your charcoal on the charcoal pan(s). Avoid spillage.
2. Follow the instructions supplied with your charcoal/fuel for lighting.
3. Use the access door to add or spread out your coals while cooking.

CAUTION: Use long-handled insulated barbecuing tools to prevent burns from hot metal or coals.

4. Turning the crank handle raises or lowers the pan to increase or decrease the grilling heat as you desire.

ACCESSORIES

WARMING RACK

The warming rack (See Fig. 2-1) is pre-assembled at the factory and is useful in keeping food warm during or after cooking.

Note: Please take into consideration that the warming rack moves closer to the grill when the oven lid is closed.

Fig. 5-1

AIR SHUTTERS

CAUTION: The air shutters become very hot when the grill is in use. Use a tool or heat-insulated glove to adjust the air shutters.

The air shutters (Fig. 5-1) on both sides of the oven can be used to regulate the flow of air to the coals when the oven is closed.

Fig. 5-2

CHARCOAL PROTECTOR

The charcoal protector allows meat drippings to drip down to the drip tray without affecting the charcoal.

Place it over the coals as shown in Fig. 5-2.

DRIP TRAY SPACER

The drip tray spacer (see Parts List, item No. 5) sits on top of the drip tray with the charcoal on top of it. It creates an air space to prevent the drip tray from overheating.

USING THE GRILL BRUSH

Purchase a Fire Magic® stainless-steel grill brush to keep your grid top clean. Complete with scraper for large particles and replaceable head with brass bristles for overall cleaning.



Fig. 5-3

Grill brush with replacement head

USING THE COOKING GRID LIFTER

Hold the grid lifter by gripping the center section with the prongs pointing down (use an oven mitt or heavy glove if the grill is hot). Insert the notched end of the grid lifter into the cooking grid, in front of the midway point (front to back; Fig. 5-4), and central (left to right; Fig. 5-5). Twist the grid lifter (clockwise or counterclockwise) so the handle is parallel to the grid rods. This “seats” the spiked end of the grid lifter between two rods, enabling you to safely lift the grid out of the grill. Lift slowly and adjust the grid lifter, if necessary, to balance.



Fig. 5-4

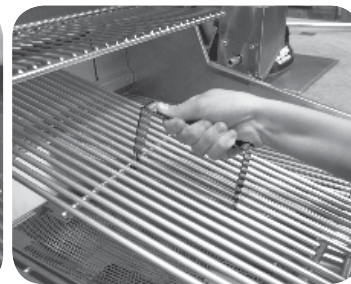

Fig. 5-5

Placement of the grid lifter in cooking grid

CLEANING

CARE AND CLEANING

Your new Fire Magic® grill represents the latest and most advanced technology available. In order to continue to enjoy the benefits of this technology and to protect your investment, we recommend the following.

Cover your grill with a Fire Magic® cover when not in use.

Clean the unit with a quality stainless-steel cleaner at least once a month (see Fig. 5-6). For thorough cleaning, the oven handle assembly may be removed (see Fig. 5-7).

Note: In a humid environment, due to the nature of stainless steel, iron oxide

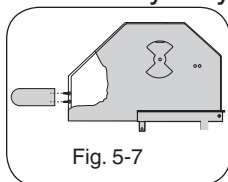

Fig. 5-7

deposits may appear. Do not be alarmed – these deposits are removable with stainless steel cleaner during periodic maintenance.

The inside of your grill, especially the removable drip tray, may be cleaned periodically with oven cleaner if desired. Follow the oven cleaner instructions for proper use.

By following these recommendations, you will enjoy the beauty and power of your Fire Magic® grill for many years to come.

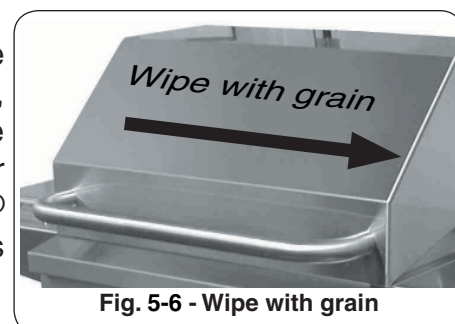

Fig. 5-6 - Wipe with grain

FIRE MAGIC® STAINLESS-STEEL CHARCOAL GRILL LIMITED WARRANTY

FIVE-YEAR WARRANTY - Fire Magic® stainless steel charcoal grills (excluding the charcoal pan and ash tray) are warranted for five (5) years from the date of purchase of your Fire Magic® charcoal grill.

ONE-YEAR WARRANTY - Fire Magic® charcoal pan and ash trays are each warranted for one (1) year from the date of purchase of your Fire Magic® charcoal grill.

PLEASE KEEP A COPY OF YOUR SALES SLIP FOR PROOF OF PURCHASE

This warranty applies to the original purchaser and to single family residential use only. It commences from date of purchase, and is valid only with proof of purchase.

This warranty does not cover parts becoming defective through misuse, accidental damage, electrical damage, improper handling, storage, and/or installation. Product must be installed (and gas must be connected) as specified in the instructions or operator's manual, by a **qualified professional installer**. Accessories, parts, valves, remotes, etc., when used must be Peterson Co. product.

This warranty **does not** apply to rust, corrosion, oxidation, or discoloration, unless the affected component becomes inoperable. It **does not** cover labor or labor-related charges.

This warranty specifically excludes liability for **indirect, incidental**, or consequential damages. Some states do not allow the exclusion or limitation of incidental or consequential damages, so the above exclusion may not apply to you. This warranty gives you specified legal rights, and you may have other rights that may vary from state to state.

For additional information regarding this warranty, or to place a warranty claim, contact the R.H. Peterson dealer where the product was purchased.

ROBERT H. PETERSON CO.

Quality Check

Date: _____

Model #: _____

Serial #: _____

Inspector: _____