



## REGAL GOURMET UNIBODY SERIES 14 & 15

### OUTDOOR GAS BARBECUE

### INSTALLATION AND OPERATING INSTRUCTIONS

**INSTALLER:** Leave these instructions with consumer.

**CONSUMER:** Retain for future reference.



Photo shows Regal II gourmet with backburner

**IMPORTANT:** READ THESE INSTRUCTIONS CAREFULLY BEFORE STARTING INSTALLATION OR USE.

#### **⚠ DANGER**

##### **IF YOU SMELL GAS:**

1. Shut off the gas to the appliance.
2. Extinguish any open flame.
3. Open lid if equipped with an oven.
4. If odor continues, keep away from the appliance and immediately call your gas supplier or fire department.

#### **⚠ WARNING**

1. Do not store or use gasoline or other flammable vapors and liquids in the vicinity of this or any other appliance.
2. A propane cylinder not connected for use shall not be stored in the vicinity of this or any other appliance.

**CODE AND SUPPLY REQUIREMENTS:** This barbecue must be installed in accordance with local codes and ordinances, or, in the absence of local codes, with either the latest *National Fuel Gas Code (ANSI Z223.1/NFPA 54)*, and *Natural Gas and Propane Storage and Handling Installation Code (CSA-B149.1)*.

This appliance and its individual shutoff valves must be disconnected from the gas supply piping system when testing the system at pressures in excess of ½ psig (3.5 kPa).

This appliance must be isolated from the gas supply piping system by closing its individual manual shutoff valves during any pressure testing of the gas supply system at pressures up to and including ½ psig (3.5 kPa).

#### **⚠ WARNING**

Improper installation, adjustment, alteration, service or maintenance can cause injury or property damage. Refer to this manual. For assistance or additional information consult a qualified professional installer, service agency, or the gas supplier.

All electrical outlets in the vicinity of the barbecue must be properly grounded in accordance with local codes or, in the absence of local codes, with the *National Electrical Code, ANSI/NFPA 70*, or the *Canadian Electrical Code, CSA C22.1*, whichever is applicable.

Keep all electrical supply cords and fuel supply hoses away from any heated surface.

Certified to ANSI: Z21.58-2005



Robert H. Peterson Co. • 14724 East Proctor Ave. • City of Industry, CA 91746

# CONTENTS

TOOLS REQUIRED-CHECK LIST	2
PRODUCT DATA TABLE	3
FIRE MAGIC REGAL I & II GOURMET UNIBODY GAS BARBECUE PARTS LIST	3
FIRE MAGIC REGAL I & II GOURMET UNIBODY BACKBURNER GAS BARBECUE PARTS LIST	4
FIRE MAGIC REGAL I & II BACKBURNER & OVEN PARTS LIST	5
PLANNING FOR INSTALLATION OF YOUR REGAL GOURMET BARBECUE	6
ENSURING PROPER COMBUSTION AIR AND COOLING AIR FLOW	6
VENTILATION OF ENCLOSURES	6
ELECTRICAL OUTLETS	6
EXHAUST REMOVAL	6
GAS SUPPLY REQUIREMENTS	6
SAFE USE & MAINTENANCE OF PROPANE GAS CYLINDERS	6
GAS SUPPLY AND MANIFOLD PRESSURES	6
SAFE USE & MAINTENANCE OF PROPANE GAS CYLINDERS	7
CHECKING AND CONVERTING GAS TYPE	8
CHECKING AND CONVERTING THE REGULATOR	8
MAIN BURNER ORIFICE SIZE CHECKING/CONVERSION	9
MAIN BURNER AIR SHUTTER ADJUSTMENT	9
CHECKING/CONVERTING THE BURNER ORIFICES	9
BACKBURNER ORIFICE SIZE CHECKING/CONVERSION (IF EQUIPPED)	10
INFRARED BURNER ORIFICE SIZE CHECKING CONVERSION (IF EQUIPPED)	10
AIR SHUTTER ADJUSTMENT	11
MAIN BURNER AIR SHUTTER ADJUSTMENT	11
BACKBURNER AIR SHUTTER ADJUSTMENT	11
BARBECUE SAFETY INFORMATION & MAINTENANCE	12
DRIP COLLECTION SYSTEM	12
LIGHTING (IGNITION) INSTRUCTIONS	13
ELECTRONIC LIGHTING	13
MANUAL LIGHTING	13
ROTISSERIE INSTRUCTIONS	14
ACCESSORIES	15
USING THE GRILL SCRAPER	15
USING THE COOKING GRILL LIFTER	15
DRIP PAN	15
THE FLAVOR GRID(S)	15
WARMING RACK	15
WOOD-CHIP SMOKER	15
BARBECUE CARE & CLEANING	16
BARBECUE COVER	16
REPLACING THE IGNITOR BATTERY	17
TROUBLESHOOTING	17
FIRE MAGIC OUTDOOR GAS BARBECUES LIMITED WARRANTY	18

## TOOLS REQUIRED-CHECK LIST

### TOOLS AND SUPPLIES REQUIRED FOR INSTALLATION

- #2 (medium) Phillips screwdriver
- Two medium size adjustable wrenches
- One pair of pliers
- One flat blade screwdriver
- \* 3/8" wrench or 3/8" socket screwdriver
- Pipe joint compound resistant to all gasses
- C.S.A. approved stainless steel flex connector  
(see top of page 8, paragraph a.)

**\*Note:** 3/8" socket if orifice change is required.

For technical help call your local Fire Magic dealer first.

# PRODUCT DATA TABLE

SPECIFICATION	VALUE	
	REGAL I 14 SERIES	REGAL II 15 SERIES
<b>Main burner</b>		
BTU per burner pair	21,300	21,300
Natural gas orifice	#52	#49
Propane gas orifice	#61	#57
<b>Backburner (if equipped)</b>		
BTU per burner pair	22,000 (6.4 kW)	22,000 (6.4 kW)
Natural gas orifice	#42 (2.375 mm)	#42 (2.375 mm)
Propane gas orifice	#54 (1.397 mm)	#54 (1.397 mm)
<b>Dimensions</b>		
Front to back	19 3/4"	23 3/4"
Width	32 1/4"	32 1/4"
Height	12"	12"

Table 1

## FIRE MAGIC REGAL I & II GOURMET UNIBODY GAS BARBECUE PARTS LIST

**Item Description**

- 1. Grill, stainless steel rod (3)  
or Porcelain cast iron (3)
- 2. Flavor grids 10"x17" (2)
- 3. Flavor grid 7"x17" (1)
- 4. Pair of burners, stainless steel (3 pair)
- 5. Burner, manifold assembly (3)
- 6. Valve manifold with backburner
- 7. Pair of clips, burner hold down (3 pair)
- 8. Electrode assembly with wiring (3)
- 9. Pair of air shutters, gas barbecue (3 pair)
- 10. Pair of springs, air shutter (3 pair)
- 11. Ignitor assembly
- 12. Knobs, Fire Magic barbecue (3)
- 13. Stainless steel gourmet face without backburner  
or Black porcelain without backburner
- 14. Drip tray assembly with match holder

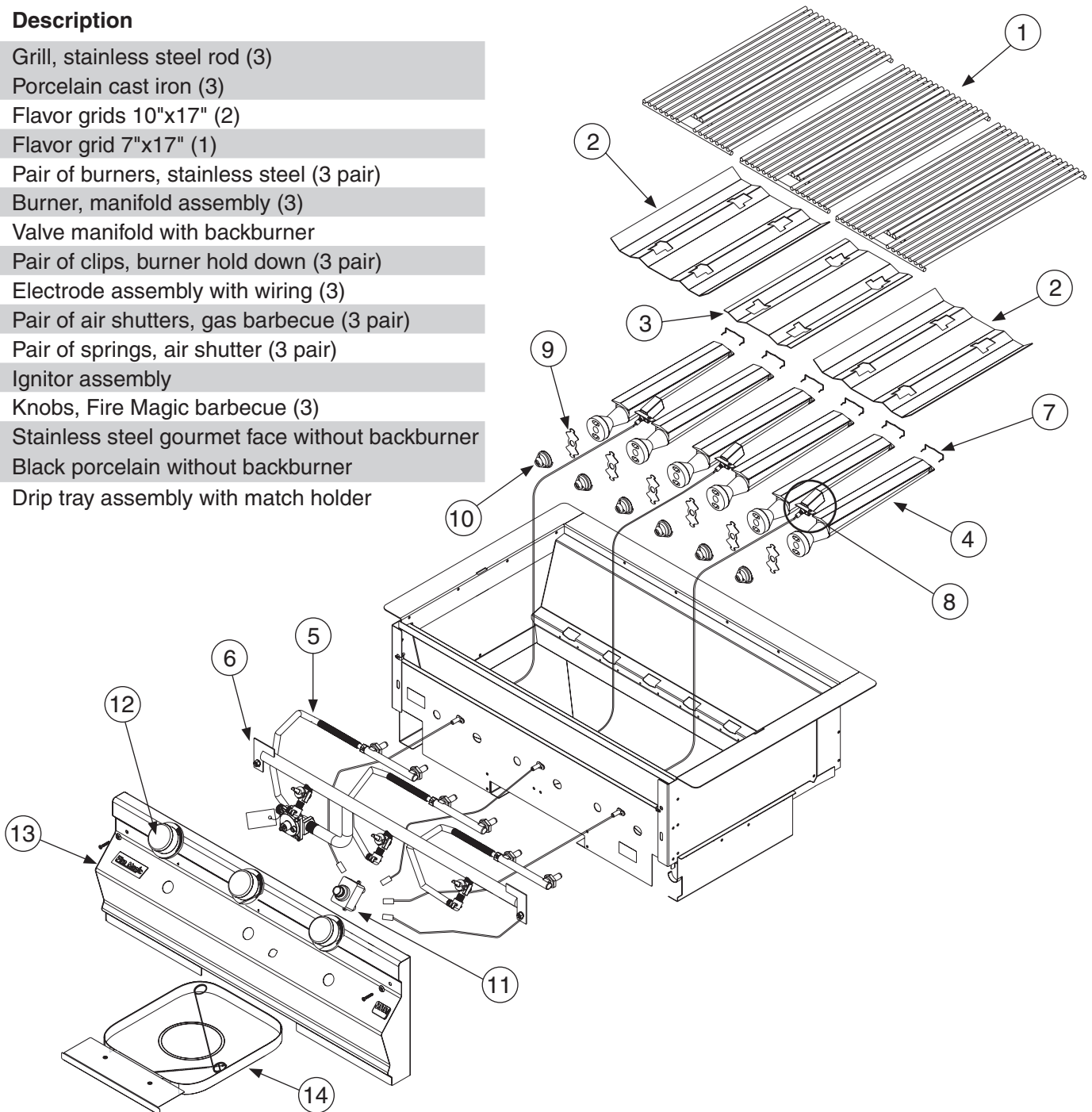

# FIRE MAGIC REGAL I & II GOURMET UNIBODY BACKBURNER GAS BARBECUE PARTS LIST

## Item Description

- 1. Grill, stainless steel rod (3)
- or Grill, porcelain cast iron (3)
- 2. Flavor grids 10"x17" (2)
- 3. Flavor grid 7"x17" (1)
- 4. Pair of burners, stainless steel (3 pair)
- 5. Burner, manifold assembly (3)
- 6. Valve manifold with backburner
- 7. Pair of clips, burner hold down (3 pair)
- 8. Electrode assembly with wiring (3)
- 9. Pair of air shutters, gas barbecue (3 pair)
- 10. Pair of springs, air shutter (3 pair)
- 11. Ignitor, assembly
- 12. Knobs, Fire Magic barbecue (3)
- 13. Knobs, Fire Magic backburner (1)
- 14. Stainless steel gourmet face with backburner
- or Black porcelain with backburner
- 15. Drip tray assembly with match holder
- 16. Backburner, manifold assembly

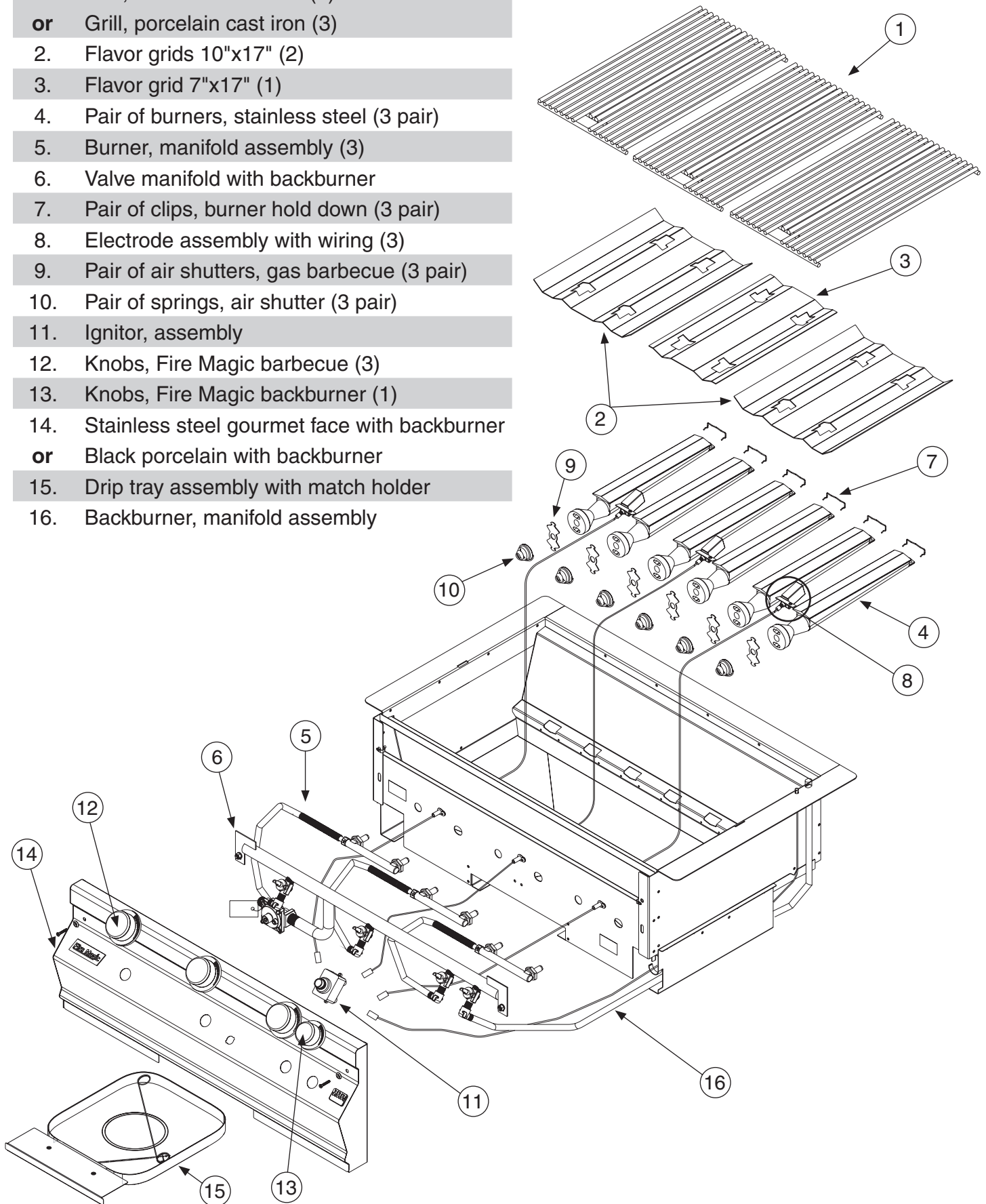

# FIRE MAGIC REGAL I & II BACKBURNER & OVEN PARTS LIST

## EXPLODED VIEW OF BACKBURNER ASSEMBLY

Parts included with the backburner assembly are inside the broken line

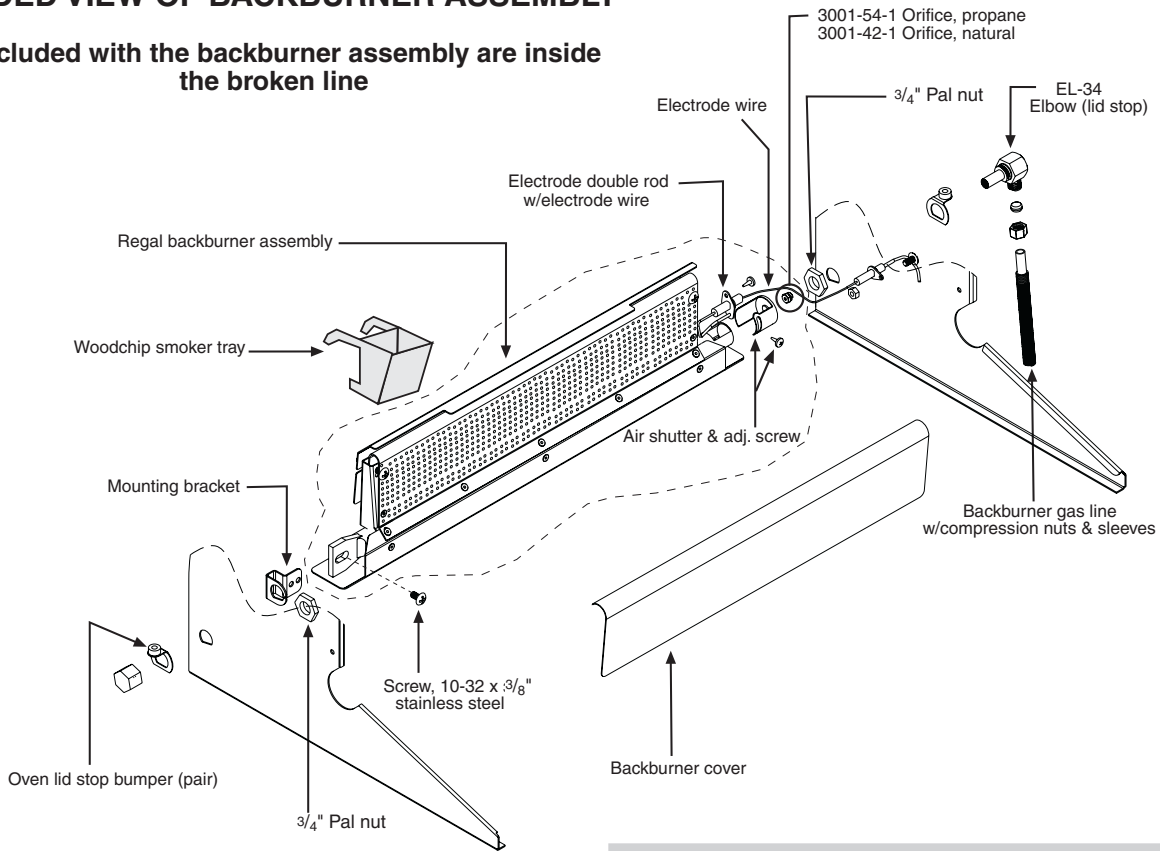

### Important

Your Fire Magic barbecue, oven, and backburner are fully pre-assembled and tested at the factory.

**DO NOT** attempt to remove the oven and backburner from the barbecue prior to or during installation. Damage to the connecting gas line and ignitor wiring may occur.

The plastic straps that secure the oven to the barbecue unit should be removed and discarded prior to lighting.

Oven w/backburner	Regal I	Regal II
Black porcelain	24732	24737
Stainless steel	24733	24738

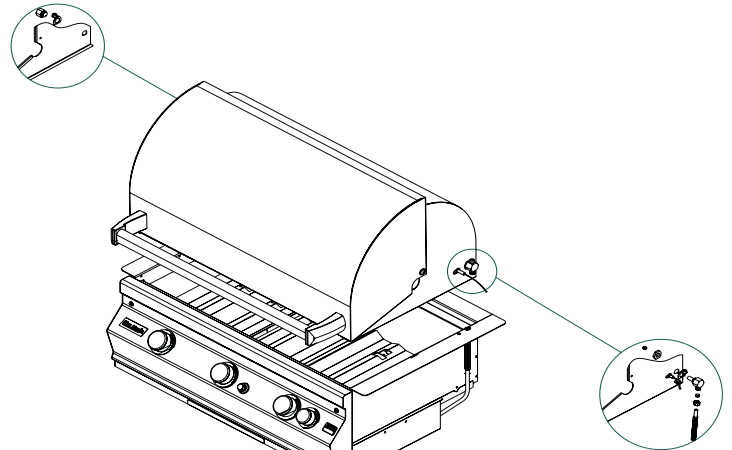

## ROTISSERIE KIT

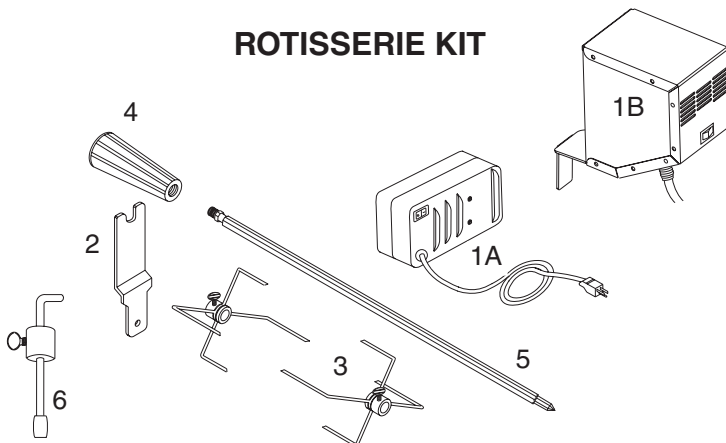

### Item No. Description

1A	Heavy duty motor
or 1B	Super heavy duty (fan cooled) motor
2	Spit bracket (with offset)
3	Spit prongs (pair)
4	Handle
5	Spit rod 7/16" hex x 32 1/2"
or	Spit rod 5/8" hex x 32 1/2"
6	Counterbalance

# PLANNING FOR INSTALLATION OF YOUR REGAL GOURMET BARBECUE

Fire Magic barbecues are designed **FOR OUTDOOR USE ONLY**.

## WARNING

Built-in models must be installed in masonry or other type of fireproof enclosure. The unit is **NOT** insulated and therefore must be installed with 18" of side and back clearance from unprotected combustible materials such as wood, plastic, or stucco with wood framing.

**DO NOT install this unit under unprotected flammable surfaces. DO NOT install or use this appliance inside a building, garage, or any other enclosed area, including recreational vehicles or boats.**

This is a **slide-in type** unit designed to fit into open-front enclosures. The front panel (face) of the unit is removable for gas hookup, servicing, and burner adjustment, and **MUST** remain removable after you install the unit.

**INSTALLER NOTE:** This unit should be installed so that it can be removed at a later date if factory service is required. Any protrusion into the barbecue enclosure may obstruct the frame and prevent the unit from sliding into place (see **GAS SUPPLY REQUIREMENTS** below).

## ENSURING PROPER COMBUSTION AIR AND COOLING AIR FLOW

Maintaining a proper air flow for your Fire Magic barbecue is essential if it is to perform as it was designed (Fig. 1). If airflow is blocked, overheating and poor combustion will result. Make sure not to block the 1" front air inlet along the bottom of the barbecue face.

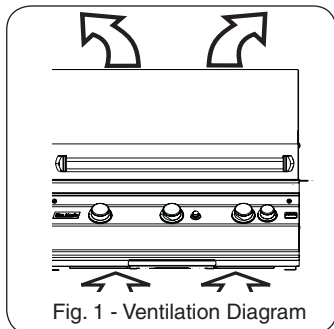

Fig. 1 - Ventilation Diagram

## VENTILATION OF ENCLOSURES

When using propane gas, take **EXTREME CAUTION** to ensure ample ventilation of gas vapor. Propane vapor is invisible and heavier than air. A **DANGEROUS EXPLOSION** could occur, resulting in **SERIOUS INJURY, OR LOSS OF LIFE** if propane gas is allowed to accumulate and then ignite.

## ELECTRICAL OUTLETS

All electrical outlets in the vicinity of the barbecue must be properly grounded.

**Installer and User Note:** Keep electrical supply cords away from all heated surfaces.

## EXHAUST REMOVAL

If installed under a patio roof, the grill area should be fully covered by a chimney and exhaust hood. An exhaust fan with a rating of 1,000 CFM (cubic feet per minute) or more may be necessary to efficiently remove smoke and other cooking by-products from the covered area. Installation in fully-enclosed patio areas is not recommended.

**Note:** The 1" front air space allows access to the drip tray.

## GAS SUPPLY REQUIREMENTS

Rigid 1/2" or 3/4" black steel pipe, or local code approved pipe for temperatures up to 800°F (427°C), is required to conduct the gas supply into the enclosure opening for connection to the unit. **DO NOT use a rubber hose within the enclosure for the barbecue unit.** Apply only joint compounds that are resistant to all gasses on all male pipe fittings. Make sure to tighten every joint securely.

**Note:** Review top of page 8, paragraph a., prior to connecting the unit.

The gas supply pipe should enter from the rear wall of the enclosure behind the barbecue unit, at least 2" from either side, and between 1" and 7" above the bottom of the barbecue unit, as illustrated by the shaded area A in Fig. 2. If it is not possible to stub the gas line in from the back of the enclosure, the connection may be made through the floor at the rear of the enclosure. Install the gas line stub at least 3" away from the side walls and 1" from the back wall, but within 5" of the back wall, as illustrated by the shaded area B in Fig. 2.

## GAS SUPPLY AND MANIFOLD PRESSURES

For **natural gas**- normal 7" water column (w.c.), minimum 3 1/2", maximum 10 1/2". For **propane gas**- normal 11" w.c., minimum 8", maximum 13".

**SAFETY NOTE:** An external valve (with a removable key) in the gas line is necessary for safety when your barbecue is not in use. It also provides for convenient maintenance.

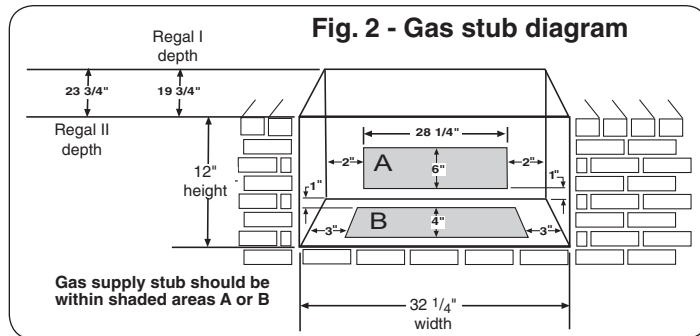

## SAFE USE & MAINTENANCE OF PROPANE GAS CYLINDERS

**READ AND FOLLOW ALL WARNINGS PROVIDED WITH YOUR PROPANE GAS CYLINDER.**

### IMPORTANT FOR YOUR SAFETY

When operating this appliance with a propane gas cylinder these instructions and warnings **MUST** be observed.

**FAILURE TO DO SO MAY RESULT IN A SERIOUS FIRE OR EXPLOSION.**

For useful advice and help with constructing your barbecue contact your local Fire Magic dealer.

# SAFE USE & MAINTENANCE OF PROPANE GAS CYLINDERS

## IMPORTANT FOR YOUR SAFETY

### READ AND FOLLOW ALL WARNINGS PROVIDED WITH THE PROPANE GAS CYLINDER.

When operating this appliance with a propane gas cylinder, these instructions and warnings **MUST** be observed.

**FAILURE TO DO SO MAY RESULT IN A SERIOUS FIRE OR EXPLOSION.**

## CYLINDER/CONNECTOR REQUIREMENTS

- Propane gas cylinders, valves, and hoses must be maintained in good condition and must be replaced if there is visible damage to either the cylinder or valve. If the hose is cut or shows excessive abrasion or wear, it must be replaced before using the gas appliance (see e.).
- This barbecue, when used with a cylinder, should be connected to a standard 5-gallon (20 lb.) propane gas cylinder equipped with an OPD (Overfill Prevention Device). The OPD has been required on all cylinders sold since October 1, 1998, to prevent overfilling.
- Cylinder dimensions should be approximately 12" (30.5cm) in diameter and 18" (45.7cm) high. Cylinders must be constructed and marked in accordance with the *Specifications for Propane Gas Cylinders of the U.S. Department of Transportation (D.O.T.)* or the National Standard of Canada, *CAN/CSA-B339, Cylinders, Spheres, and Tubes for Transportation of Dangerous Goods*.
- The cylinder must include a collar to protect the cylinder valve and the cylinder supply system must be arranged for vapor withdrawal.
- The pressure regulator and hose assembly (Fig. 7-1) supplied with this outdoor cooking gas appliance must be used. Original and replacement pressure regulator and hose assemblies must be those specified by the Robert H. Peterson Co. for connection with a cylinder connecting device identified as Type I by the *ANSI Z 21.58-2005/CGA 1.6-2005* (see PARTS LIST for ordering information).
- The propane gas cylinder valve must be equipped with a cylinder connection coupling device, described as Type I in the standard defined in paragraph e. above. This device is commonly described as an Acme thread quick coupler.
- If the propane gas cylinder comes with a dust plug, place the dust cap on the cylinder valve outlet whenever the cylinder is not in use.

## QUICK COUPLER OPERATION

**To connect the regulator/hose assembly to the propane gas cylinder valve fitting:** Press the hand nut on the regulator over the Acme thread fitting on the cylinder valve. Turn the hand nut clockwise to engage the threads and tighten until snug.

The use of pliers or a wrench should not be necessary. Only cylinders marked propane may be used.

**To disconnect:** Turn the hand nut counterclockwise until detached (Fig. 7-1).

**Important:** Before using the barbecue, and after each time the cylinder is removed and reattached, check the hose for wear (see a.) and check all connections for leaks. Turn off the barbecue valves and open the main cylinder valve, then check connections with soapy water. Repair any leaks before lighting the barbecue.

**CAUTION:** Always turn the propane cylinder main valve off after each use, and before moving the barbecue and cylinder, or disconnecting the coupling. This valve must remain closed and the cylinder disconnected while the appliance is not in use, even though the gas flow is stopped by a safety feature when the coupler is disconnected.

**Carefully** inspect the hose assembly each time before the gas is turned on. A cracked or frayed hose should be replaced immediately.

If the appliance is stored indoors, the cylinder must be disconnected and removed. **Cylinders must be stored out of doors, out of the reach of children**, and must not be stored in a building, garage, or any other enclosed area.

## FOR YOUR SAFETY

- DO NOT store a spare propane gas cylinder under or near this appliance.
- NEVER fill the cylinder beyond 80 percent full.
- IF THE INFORMATION IN "a" AND "b" IS NOT FOLLOWED EXACTLY, A FIRE CAUSING DEATH OR SERIOUS INJURY MAY OCCUR.

Fig. 7-1 Type I Acme thread quick coupler

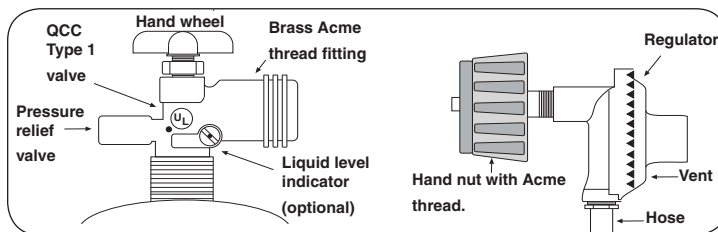

Note: Gas cylinder held in place by retainer



Fig. 7-2

- Open door to access cylinder locating tray.
- Set propane gas cylinder firmly on tray with base inserted into center hole (Fig. 7-2).

Follow instructions above to connect supply.

Fig. 7-2 & 7-3. Three easy steps to securing your propane gas cylinder.

L.P. hose connection point inside the cart

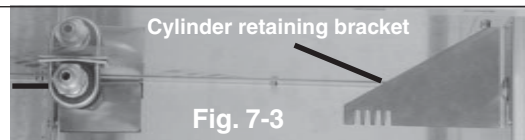

Fig. 7-3

- Gas cylinder is held securely in place with the cylinder retaining bracket (Fig. 7-3).
- Loosen the wing nut (Located behind the inner wall).
  - Lower until one of the notches in the bracket hooks over cylinder rim.
  - Tighten wing nut.

Check that cylinder is secure.

**To remove, loosen nut and raise bracket. Lift out cylinder.**

## CHECKING AND CONVERTING GAS TYPE

This barbecue comes from the factory configured for one type of gas, as marked on the label behind the barbecue face plate.

**Converting this barbecue to burn a different type of gas requires a conversion kit from the factory. The professional installer that converts this barbecue to burn a different gas must perform the following functions:**

1. Change replaceable, brass gas orifices (included at original shipping) on each burner to match the new gas type (see PRODUCT DATA TABLE, Table 1).
2. Switch the convertible gas regulator (included at original shipping) to match the new gas type (see below).
3. Plumb the unit to the new gas supply.
4. Apply a new label behind the faceplate, indicating the new gas the barbecue will burn (included with conversion kit).

### **WARNING**

**HAZARDOUS OVERHEATING WILL OCCUR IF A NATURAL GAS ORIFICE IS USED WITH PROPANE GAS. IF YOU ARE NOT SURE IF THE CORRECT ORIFICES ARE INSTALLED, OR IF AN ORIFICE CHANGE IS NECESSARY, REFER TO THE FOLLOWING INSTRUCTIONS.**

**CAUTION:** Make sure the barbecue is at a safe temperature and isolated from gas and electrical supplies before beginning the tasks outlined below.

**Note:** The cooler the barbecue, the greater the tolerances between the stainless steel parts, and therefore, the easier to disassemble and reassemble parts of the barbecue.

**CAUTION:** For your safety, exercise caution and use adequate hand protection, such as gloves, when handling potentially sharp sheet-metal parts.

## CHECKING AND CONVERTING THE REGULATOR

Barbecue regulator:  
note the cap on top

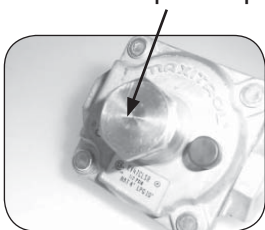

**Note:** Each end of the plastic converter is engraved with either the letters NAT or L.P. (propane) for the respective gasses. When the converter is in the cap and the cap is held uppermost, the letters seen indicate the gas that the regulator is set up for.

To convert the regulator from one gas to another, follow steps 1-4.

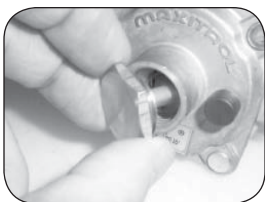

**STEP 1:**  
Unscrew and remove the cap from the regulator, extracting the converter.

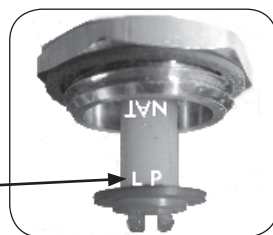

**STEP 3:**  
Turn the converter around and replace, carefully, into the center of the cap (it will snap into place). Check that you can read the type of gas the unit is set for.



**STEP 2:**  
Remove the converter (the plastic stalk) by carefully pulling it away from the center of the cap (it will snap out of its seating).

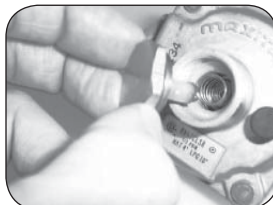

**STEP 4:**  
Replace the unit into the regulator and screw down until snug.

### **WARNING**

THIS APPLIANCE REGULATOR IS RATED FOR 1/2 PSI MAXIMUM. IF YOUR GAS SUPPLY IS GREATER THAN 1/2 PSI, AN ADDITIONAL REGULATOR MUST BE INSTALLED TO REDUCE THE INPUT PRESSURE TO THE BARBECUE TO 1/2 PSI OR LESS. SEE GAS SUPPLY REQUIREMENTS SECTION FOR PROPER GAS SUPPLY PRESSURE.



## CHECKING/CONVERTING THE BURNER ORIFICES

### BACKBURNER ORIFICE SIZE CHECKING/ CONVERSION (IF EQUIPPED)

Before beginning, make sure you have the proper tools for the task.

This task requires:

- a #2 Phillips-head screwdriver
- a #2 flat-head screwdriver
- a  $\frac{3}{8}$ " wrench or socket screwdriver

**Note:** It may be necessary to remove the rotisserie rod before beginning this procedure.

1. Remove the heating rack, if installed, and set it aside.
2. Remove the backburner cover, if installed.
3. Unscrew both backburner face plate screws using a Phillips-head screwdriver and set them aside.
4. Remove the backburner face plate by pulling the bottom toward the front of the barbecue and rotating it upward and outward until the two top tabs can be removed from the back wall of the barbecue. Set it aside.
5. Remove the backburner assembly anchoring screw on the lower left of the backburner using a Phillips-head screwdriver and set it aside.
6. Pull the backburner assembly to the left, clear of the orifice, and then rotate the top forward and downward and lay it face down across the main burner dividers.

**CAUTION:** Be careful not to damage the wires connected to the backburner assembly.

7. Use the socket driver to remove the exposed orifice and replace it with the correct orifice for the gas to be burned. (See Product data table for correct orifice sizes based on burner type and gas type).
8. Replace the backburner assembly and re-insert the anchoring screw. Center the backburner assembly so that the backburner face plate will fit over it. Tighten the anchoring screw using a Phillips-head screwdriver.

**Note:** Now that the backburner faceplate is off, it is an excellent time to adjust the air shutter, if needed. See section on air shutter adjustment in this manual.

9. Replace the backburner face plate by first inserting the upper tabs into the slots in the back wall of the barbecue and then rotating the bottom downward and inward.
10. Replace the two backburner faceplate screws using a Phillips-head screwdriver.

**Tip:** Re-attaching the backburner faceplate may be easier if the left screw is replaced before the right screw.

### INFRARED BURNER ORIFICE SIZE CHECKING CONVERSION (IF EQUIPPED)

Before beginning, make sure you have the proper tools for the task.

This task requires:

- a deep  $\frac{3}{8}$ " hex nut driver with a spacer (#6 nut)

1. Remove the grill from above the burner you are working on by lifting it first from the front and set it aside.
2. Remove the flavor grid from above the burner you are working on and set it aside.
3. Remove the infrared burner by lifting the back of the burner up so that both tabs are freed from their slots, then lift the burner toward the back of the barbecue and upward. Set the burner aside.
4. Use the nut driver to remove the exposed orifice and replace it with the correct orifice for the new gas. (See Product data table for correct orifice sizes based on burner type and gas type).
5. Replace the infrared burner by first sliding it over the orifice, then lining up the two tabs in back of the burner with the two slots in the back of barbecue and lowering them carefully into place.
6. Replace the flavor grid and then the grill so that the cutout section of the grill is forward.

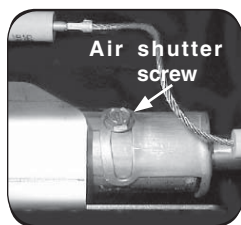

Fig. 10-1

# AIR SHUTTER ADJUSTMENT

## MAIN BURNER AIR SHUTTER ADJUSTMENT

**Important:** The air shutters must be adjusted after installation. If not, this appliance may not light, heat evenly, or cook properly.

Main burner air shutters are easily accessed by removing the front panel (face). The air shutters are located at the front of the burners behind the face (see PARTS LIST). The air shutter has a small dimple (see Fig. 11-1), which allows it to lock into notches in the burner face. This prevents the air shutter from moving.

### WARNING

**USE PROPERLY INSULATED TOOLS TO MAKE THESE ADJUSTMENTS. NEVER TOUCH A HOT BARBECUE DIRECTLY TO MAKE ADJUSTMENTS.**

1. **Using the tip of a long screwdriver**, close the air shutters by turning the tabs to a vertical position (Fig. 11-2).
2. Light the barbecue in accordance with the LIGHTING INSTRUCTIONS and burn for 2 minutes with the knobs on **HI LIGHT** and the oven open.
3. After burning for two (2) minutes, open the air shutters, **using the tip of a screwdriver**, until the flames lift off, or appear not to be touching the burners (Fig. 11-1).
4. Begin closing the air shutters, **with the tip of a screwdriver**, until the flames appear to burn while touching the burner ports. (Fig. 11-2).

**Note:** You may then see short yellow tips on the flames. If flames are a lazy yellow, open the air shutters until the flame is blue with yellow tipping.

**Note:** Barbecues, in some installations, achieve a better air/gas mixture and will ignite more quickly if the valve is first turned beyond **HI LIGHT** to **LOW** for lighting.

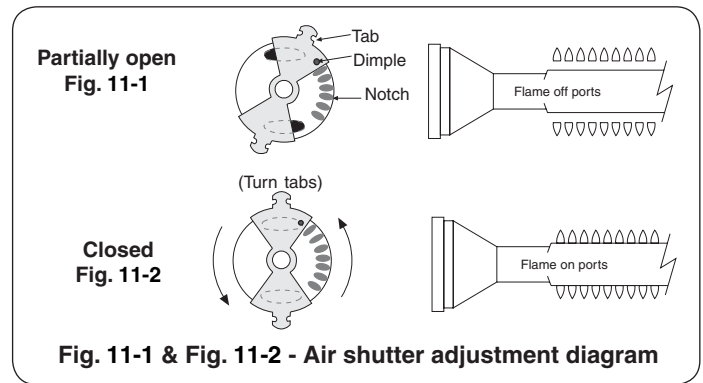

## BACKBURNER AIR SHUTTER ADJUSTMENT

**Important:** It is normal for the backburner to smoke when it is burned for the first time. Burning your backburner on **HI LIGHT** for approximately 15 minutes will eliminate the smoking.

- a. The air shutter on your backburner is preset at the factory. However, due to atmospheric conditions and different gas pressures, it may be necessary to adjust the air shutter to obtain a proper burn.
- b. First remove the backburner cover (if installed), then loosen the air shutter screw (see Fig. 11-3). It may be necessary to use pliers to turn the air shutter. Light the backburner. With the control knob on **HI LIGHT** adjust the air shutter to have a blue flame that is not lifting off the burner (it may also have slightly yellow tips).
- c. Tighten the air shutter adjustment screw.

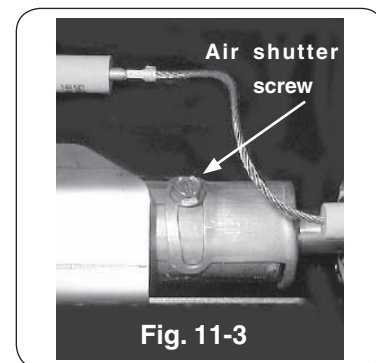

# BARBECUE SAFETY INFORMATION & MAINTENANCE

## Each time you use the barbecue, make sure that:

1. The area around the barbecue is clear of flammable vapors, liquids, and substances such as gasoline, yard debris, wood, etc.
2. There is no blockage of the air flow through the vent space located below the face of the unit.
3. When using propane gas:
  - a. The special ventilation openings in the enclosure are kept free and clear of debris (see PLANNING THE LOCATION OF THE BARBECUE).
  - b. If connected to a propane cylinder, the rubber hose attached to the regulator is carefully inspected before each use.
  - c. The propane cylinder, regulator, and rubber hose are installed in a location not subject to heating above 125° F (51° C).
4. The burner flames burn evenly along both sides of each burner with a steady flame, which is mostly blue with yellow tipping. (Refer to section on AIR SHUTTER ADJUSTMENT.) If burner flames are not normal, check the orifice and burner for insects or insect nests.
5. The in-line gas valve or gas cylinder valve is always shut **OFF** when the barbecue is not in use.
6. The drip collector hole is clear and unobstructed. Excessive grease deposits can result in a grease fire.
7. The barbecue is free and clear from combustible materials, gasoline, and other flammable vapors and liquids.
8. Do not operate the backburner with its cover installed.

## DRIP COLLECTION SYSTEM

The drip collector in this barbecue is part of the unit's main frame and is located below the burners. The drip collector has one hole that will allow excess drippings to fall through during cooking, while separating the firebox from the drip tray. Clean the drip tray after each use.

The drip collector allows you to brush or scrape residue from the barbecue's inner liner into the drip tray. Following the manufacturer's instructions and regular cleaning of the barbecue's interior with oven cleaner, will help to prevent grease fires.

Periodically, check the burners to make sure they are clear of debris. Properly adjusted burner flames burn evenly along both sides of each burner with a steady flame (mostly blue with yellow tipping). If burner flames are not normal, check the orifice and burner for insects or insect nests. (See section on CHECKING/CONVERTING THE BURNER ORIFICES for instructions on burner removal and replacement.)

Check the burner ports at least annually for blockage by removing the burner (see orifice changing instructions) and visually inspect the gas intake tube for insects and nests. A clogged tube can lead to a fire beneath the grill.

### **WARNING**

**NEVER cover the *entire* cooking or grill surface with griddles or pans. Overheating will occur and burners will not perform properly when combustion heat is trapped below the cooking surface.**

**CAUTION:** NEVER spray water on a hot gas unit.

# LIGHTING (IGNITION) INSTRUCTIONS

Read entire instructions before lighting and follow these instructions each time you light the barbecue.

## ELECTRONIC LIGHTING

1. Open all lids and remove all covers from the burners you wish to light.
2. Turn all gas control knobs to their **OFF** positions.
3. Turn on the gas at its source.

**Note:** No matter which lighting method you use,

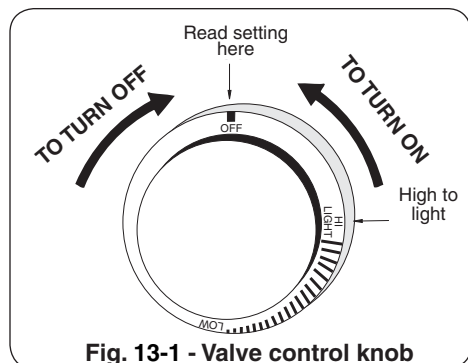

Fig. 13-1 - Valve control knob

**DO NOT** turn on the gas to more than one burner at a time. Adjacent barbecue burners will cross-ignite and gas flow may be restricted.

**CAUTION:** If the burners do not light within 5 seconds, depress the control knob and turn the knob to **OFF**. **WAIT 5 MINUTES** before repeating step 4. If you smell gas, follow the instructions on the cover of this manual. If the burners still do not light after several attempts, refer to the instructions for **MANUAL LIGHTING**.

4. Depress the control knob for the burner to be lit and turn it to the **HI LIGHT** position, then press the ignition button. Once the burner lights, release the ignition button.
5. Repeat step 4 for each additional burner to be lit.

## FOR PROPANE ONLY

Propane tanks are equipped with a safety shut-down device that may cause low or no gas pressure/flame at the burners if operating and lighting instructions are not followed exactly (See important note in the **TROUBLESHOOTING** section for more details.)

## ADJUSTING THE FLAME

The knobs on the face of the barbecue control the valves and adjust the flame height. The first labeled position is **OFF**, the second **HI LIGHT**, and the third **LOW**. In between the **HI LIGHT** and **LOW** labels are mid-point marks. Flame height can be set anywhere between the **HI LIGHT** and **LOW** settings.

The height of the flame **with a valve in LOW position** may be further regulated by means of a small adjusting screw in the center of the valve stem. This screw is accessible by removing the valve knob, which pulls straight off the end of the valve stem.

## MANUAL LIGHTING

**CAUTION:** Always wait 5 minutes for gas to clear after any unsuccessful lighting attempt.

1. Follow steps 1 through 4 (left).
2. Insert either a burning long-barrel butane lighter, a burning long-stem match, or a burning match held by a wire extension holder (Fig. 13-2) through the cooking grids to the burner (Fig. 13-3). For backburners, hold the flame against the perforated material of the backburner. For sideburners, hold the flame against the burner.
3. While holding the match or lighter flame next to the burner, depress the appropriate burner control knob and turn it counterclockwise to the **HI LIGHT** position. When the burner lights, remove the lighter or match.



Fig. 13-2 - Match holder

4. If the burner does not light, **IMMEDIATELY** depress the knob and turn the burner control knob to **OFF**. **WAIT 5 MINUTES** before repeating steps 2 through 4 of the **MANUAL LIGHTING INSTRUCTIONS**.

**Note:** Barbecues in some installations achieve a better air/gas mixture and will ignite more quickly if the burner control knob is first turned beyond **HI LIGHT** to **LOW** for lighting.



Fig. 13-3 - Manual lighting

**REMEMBER:** FOR SAFE MANUAL LIGHTING, PLACE A BURNING MATCH OR BUTANE LIGHTER BESIDE THE BURNER - **THEN TURN ON THE GAS** (see Fig. 13-3).

## SHUTTING OFF THE GRILL

To shut off the grill, push in each valve control knob and turn it clockwise to the **OFF** position.

Always close the valve to the gas supply after each use of the barbecue.

# ROTISSERIE INSTRUCTIONS

## USING YOUR BACKBURNER AND ROTISSERIE

Rotisserie cooking with the backburner is accomplished without use of the main burners. Follow the steps in the appropriate sections below to set up and use these accessories (see PARTS LIST for image).

### SET UP

1. Remove the backburner cover (if present) by sliding it upward off of the backburner.
2. Remove the cooking grids from your barbecue, if necessary, to obtain maximum clearance for larger cuts. The flavor grids may also be removed if required.  
**Tip:** Aluminum foil or a baking pan may be placed over the main burners, a little forward of center, to catch excess drippings from the meat.
3. Attach the rotisserie motor to the barbecue frame by inserting the tab of the bracket attached to the motor into the slot on the right of the barbecue so that the spit rod will fit into the motor drive socket from the left. If left-side spit support is not already in place, insert it into the tab on the left side of the barbecue at this time.
4. Follow the LIGHTING INSTRUCTIONS to light the backburner.
5. Allow the backburner to preheat for approximately 10 minutes on **HI LIGHT** setting.

### PUTTING THE MEAT ON THE SPIT ROD

1. Slide the meat and spit prongs onto the spit rod so the meat is centered and balanced as well as possible.
2. Tighten the spit prongs into place so that the meat remains in a fixed position on the rod and the meat rotates with the rod.

**Important:** The counterbalance, which is included with your rotisserie kit, should be used to balance the load on your rotisserie and prolong the life of your motor. Heavy unbalanced meats can stress the rotisserie motor and may cause motor failure.

### USING THE COUNTERBALANCE SUPPLIED WITH YOUR ROTISSERIE

1. Hold the spit rod at each end and lift. **Do not grip the rod.** Let the rod rotate so the heavy side of the meat hangs down naturally.

2. Turn the counterbalance on the spit so the counterbalance rod and weight point upward, or opposite from the heavy side of the meat. Tighten the counterbalance rod in the hub against a flat surface of the spit rod to secure (Fig. 14-1).

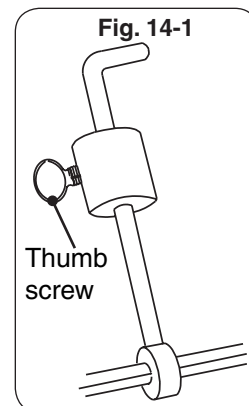

3. Loosen the thumb screw and slide the weight along the counterbalance rod to balance the meat. Since meats are not a uniform shape, it may not be possible to achieve a perfect balance. Properly balanced meat should not rotate when you hold the spit rod loosely by the ends.
4. Make sure the counterbalance will not strike the barbecue frame when the rotisserie is started.

### RUNNING THE ROTISSERIE

1. Place the pointed end of the spit rod into the motor drive socket and rest the handle end of the spit rod in the spit bracket on the right side of the barbecue.
2. Plug in (if necessary) and turn on the rotisserie motor.
3. Use a standard roasting guide to estimate the length of time for your meat. A meat thermometer may also be used to tell when your favorite cuts are cooked to your liking. When testing temperatures with a thermometer, turn off the rotisserie motor and turn the backburner on **LOW**. This will keep the meat from over cooking on one side.

**Note:** When burning properly, the backburner flames will be blue with yellow tipping and the grating will glow red. The first time it is used the backburner may smoke a little.

**Important:** Operate your backburner with the oven closed. This simulates an oven effect and helps your meat cook faster. Constant rotation of the spit assures even cooking and maximum retention of juices.

**Note:** On large cuts of meat or whole turkeys, it may be necessary to reduce the heat from your backburner. Cooking your food at a lower temperature for a longer period of time will keep the outer surface from burning while cooking the interior of your meat. In any case it is normal for the back burner grating to glow red when operating properly.

## ACCESSORIES

### USING THE GRILL SCRAPER

The triangular stainless-steel piece with serrated edges is designed to be used as a tool to quickly and easily scrape food particles and drippings off the grill after barbecuing. To use it, simply align one of the edges of the scraper so that the cooking grid bars fit into the grooves in the serrated edge, and then scrape it along the length of the cooking grid. Repeat as needed.

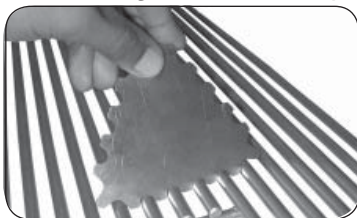

Fig. 15-1  
Grill scraper use

### WARMING RACK

The warming rack (Fig. 15-2) is packed separately with the barbecue.

To install the warming rack, lift the front of the rack up slightly and insert the rack hangers into the two holes in the back of the barbecue above the backburner. Then lower the front of the rack into a level position to lock the rack in place.

To remove the warming rack, lift up on the front of the rack until the rack hangers pull free from their supporting holes.

**Note:** For best results, remove the warming rack before using the rotisserie.

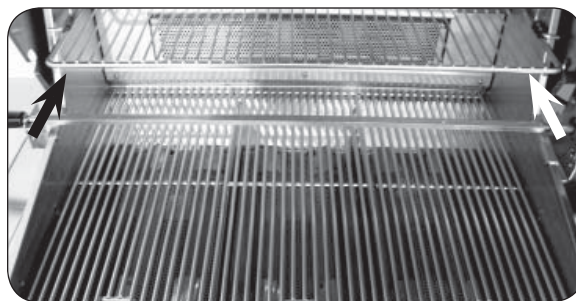

Fig. 15-2 Warming rack in place inside oven

### USING THE COOKING GRILL LIFTER

Hold the grill lifter by gripping the center section with the prongs pointing down (use an oven mitt or heavy glove if the grill is hot). Insert the notched end of the grill lifter into the grill, in front of the midway point (front to back-Fig. 15-3), and central (left to right-Fig. 15-4). Twist the grill lifter (clockwise or counterclockwise) so the handle is parallel to the grill rods. This “seats” the spiked end of the grill lifter between two rods, enabling you to safely lift the grill out of the barbecue. Lift slowly and adjust the grill lifter, if necessary, to balance.

### DRIP PAN

The drip collection system allows you to brush or scrape excess dried residue inside the barbecue directly into the drip pan (see PARTS LIST for drip pan location). To simplify cleanup when using the rotisserie, you may place a baking pan or foil under the rotisserie to collect the drippings. Clean the drip pan after each use.



Fig. 15-3

Placement of the grill lifter in grill

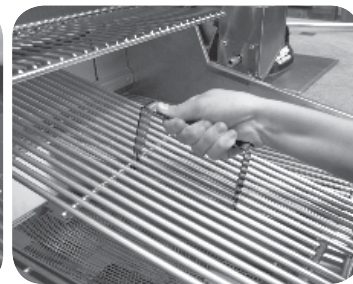

Fig. 15-4

### THE FLAVOR GRID(S)

Place each flavor grid directly on a burner or burner pair. Center each grid over the burner, oriented as shown in Fig. 15-6.

**Note:** This allows heat from the burners to be evenly distributed throughout the cooking area. The flavor grids heat and cool quickly, making the barbecue very responsive to the changes in heat from the burners.

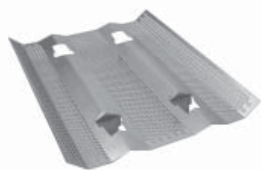

Fig. 15-6

### WOOD-CHIP SMOKER

Your optional backburner is supplied with a wood-chip box. The wood-chip box is designed to sit on top of the backburner assembly over the notch in the heat deflector (see Fig. 15-5). This box is designed to be used when the backburner is in use. To use the box, just dampen your favorite wood chips and put them inside; then set it in place. If you wish to refill the wood-chip box when it is hot, you may carefully handle it using a pair of insulated pliers. You must be very cautious not to get burned.

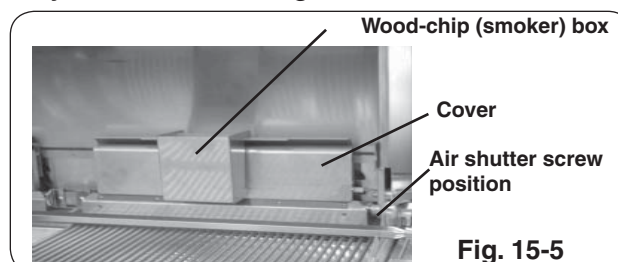

Fig. 15-5

## BARBECUE CARE & CLEANING

### CARE AND CLEANING

Your new Fire Magic barbecue represents the latest and most advanced technology available. In order to continue to enjoy the benefits of this technology and to protect your investment, we recommend the following:

Cover your barbecue with a Fire Magic cover when not in use.

Clean the unit with a quality stainless steel cleaner at least once a month (see Fig. 16-1).

**Note:** In a humid environment, due to the nature of stainless steel, iron oxide deposits may appear. Do not be alarmed – these deposits are removable with stainless steel cleaner during periodic maintenance.

Check the burner ports at least annually for blockage by removing the burner (see orifice changing instructions) and visually inspecting the gas intake tube for insects and nests. A clogged tube can lead to a fire beneath the grill.

The inside of the barbecue may be cleaned periodically with oven cleaner if desired. Follow the oven cleaner instructions for proper use.

By following these recommendations, you will enjoy the beauty and power of your barbecue for many years to come.



Fig. 16-1 - Wipe with grain

## BARBECUE COVER

### PROTECTING YOUR BARBECUE

An optional heavy-duty cover will protect the finish on your barbecue and preserve your investment. The water repellent material will shield your barbecue from corrosion and oxidation.

To provide a custom fit, each cover has been cut and sewn by hand for a particular smoke oven model. Make sure to give the model number of your barbecue when ordering a cover from the manufacturer or your local dealer.

To maintain and protect your barbecue cover, occasionally wipe the outside with a sponge soaked

in water and a mild household detergent or cleaner, and rinse with a clean damp cloth.

**Important:** Allow your barbecue to cool before covering.

**Important:** Always close the gas supply shut off valve to the barbecue. If storing the barbecue for a long period of time, disconnect the barbecue from the gas supply completely.

Always check the burners after long periods of disuse to look for obstructions that may hamper performance and safe operation of your barbecue.



Fig. 16-2

## REPLACING THE IGNITOR BATTERY

1. Remove the ignitor cover by turning it counterclockwise.



**Important:** Do not attempt to pull or turn the rubber cap.



2. Remove battery for replacement. The battery is re-installed with the negative (-) end out.



3. After properly inserting the battery, replace the ignitor cover by turning the cap clockwise.



**Note:** If you have accidentally removed the rubber cap, follow the instructions below to replace it.

1. Pull the rubber cap and the inner plastic sleeve apart.  
 2. Carefully insert the rubber cap into the ignitor cover so it sits behind inner lip.  
 3. Turn the cap over and slide the plastic sleeve into the cap.



## TROUBLESHOOTING

If you have trouble with the gas barbecue, please use this list to identify the problem. By trying one or more of the solutions to the possible cause you should be able to solve the problem. If this list does not cover your present problem or if you have other technical difficulties with the barbecue, please contact your local barbecue dealer.

PROBLEM	POSSIBLE CAUSE	CORRECTION
<b>Ignition system failure</b>	1) Improper air shutter adjustment	1) Adjust air shutters.
	2) Ignition wire disconnected	2) Re-plug wires into generator.
	3) Low gas pressure	3) Adjust or replace battery.
	4) Dead battery	4) Replace battery.
<b>Insufficient heat</b>	5) Improper air shutter adjustment	5) Adjust air shutters.
	6) Using propane orifice for natural gas	6) Change orifices.
	7) Low gas pressure/flame (natural)	7) Have gas company check the operating pressure at the barbecue.
	8) Low gas pressure/flame (propane)	8) Refill propane tank, or reset propane tank safety*: Shut off all valves including propane tank and follow lighting instructions exactly.
<b>Uneven heating</b>	9) Burner ports partially blocked by debris	9) Remove burners and clean out ports.
	10) Small spiders or insects in burner	10) Inspect burners for spider webs or other debris that may block gas flow.
<b>Rotisserie noisy</b>	11) Rotisserie out of balance	11) Adjust counterbalance.

**Note:** \*Propane tanks are equipped with a safety shut-down device that may cause low or no gas/flame at the burners if operating and lighting instructions are not followed exactly. If you suspect the propane tank safety shut-off is in effect, shut off all burner control valves and the propane tank valve. Then read and follow the LIGHTING INSTRUCTIONS exactly. Lighting instructions are located in the owner's manual and printed on the barbecue's metal drip tray. If the problem persists continue troubleshooting or contact your local dealer or R. H. Peterson for assistance.

# FIRE MAGIC OUTDOOR GAS BARBECUES LIMITED WARRANTY

**PLEASE COMPLETE AND RETURN YOUR REGISTRATION CARD, WHICH IS INCLUDED WITH YOUR BARBECUE**

**LIFETIME WARRANTY** - Fire Magic cast stainless steel burners, stainless steel rod cooking grids, and stainless steel housings (including liners, frames, ovens, and barbecues faces) are warranted for as long as you own your Fire Magic barbecue.

**FIFTEEN YEAR WARRANTY** - Fire Magic cast brass burners, brass valves, backburner assemblies (except ignition parts), manifold assemblies, and porcelain hoods and faces are warranted for 15 years from the date of purchase of your Fire Magic barbecue.

**THREE YEAR WARRANTY** - Fire Magic sideburners and all other Fire Magic barbecue components (except ignition and electronic parts) are warranted for 3 years from the date of purchase of your Fire Magic barbecue.

Fire Magic ignition systems, electronic components (including lights and thermometers), and barbecue accessories are warranted for one year from date of purchase.

## PLEASE KEEP A COPY OF YOUR SALES SLIP FOR PROOF OF PURCHASE

This warranty applies to the original purchaser with invoice or proof of purchase and covers Fire Magic products intended for personal, family, or household usage only. It does not apply to rust, corrosion, oxidation, or discoloration, which may occur due to moisture or overheating, unless the affected component becomes inoperable. This warranty does not cover parts becoming defective by misuse, accidental damage, improper handling, and/or installation. It does not cover labor or labor related charges. It specifically excludes liability for indirect, incidental or consequential damages. Some states do not allow the exclusion or limitation of incidental or consequential damages, so the above exclusion may not apply to you. This warranty gives you specified legal rights and you may have other rights, which may vary from state to state.

For additional information regarding this warranty, or information on how to place a warranty claim, contact your authorized Fire Magic dealer.

## ROBERT H. PETERSON CO.

Quality Check

Date: \_\_\_\_\_

Orifice # (Main): \_\_\_\_\_

Orifice # (Other): \_\_\_\_\_

Leak Test: \_\_\_\_\_

Burn Test: \_\_\_\_\_

Gas Type: NAT. / PROPANE

Model #: \_\_\_\_\_

Serial #: \_\_\_\_\_

Air Shutter: \_\_\_\_\_

Inspector: \_\_\_\_\_