

A MESSAGE TO OUR CUSTOMERS







Thank you for selecting the Outdoor Concepts TableTop Grill. We have worked hand in hand to create a product that meets our exacting standards and will provide years of pleasurable, outdoor grilling.

Because the grill has features not found on any other, we recommend that you read this entire booklet before your first use. Then, keep it in a handy place as it has answers to many questions that may arise during use.

Please contact us at any time if we can help you with questions about parts and use
(714) 903-1885.



Table of Contents

	SAFETY PRACTICES / PRECAUTIONS.....	2
	GRILL FEATURES.....	3
	SPECIFICATIONS.....	4
	USING YOUR GRILL.....	5
	CARE AND STORAGE.....	6
	WARRANTY.....	6
	GRILL RECIPES.....	7-8

Safety Practices & Precautions

Safety Practices to Avoid Injury:

The Tabletop Grill is for outdoor use only. Do not use the Tabletop grill indoors as this can be fatal.

When properly cared for, your grill will give safe, reliable service for many years. However, extreme care must be used since the grill produces intense heat and can increase accident potential. When using this appliance basic safety practices must be followed, including the following:

- Read this Care and Use Guide carefully and completely before using your grill to reduce the risk of fire, burn hazard or other injury.
- Do not use flammable materials and fluids such as gasoline, alcohol, diesel fuel, or kerosene to light or relight fires. Keep the grill away from these materials when lit.
- Exercise the same precautions you would with an open fire.
- ❗ ***Children should not be left alone or unattended in an area where the grill is being used. Never allow them to sit, stand or play on or around the grill at any time. When in use, portions of the grill get hot enough to cause severe burns.***
- Do not use charcoal in the grill.
- Do not wear flammable or loose fitting clothing such as nylon when using the Grill.
- Do not burn trash, leaves, paper, cardboard, or plywood in the Grill.
- Do not store the Grill with combustible materials inside. Do not store the Grill until the unit is cold.
- Use BBQ mitts when handling the Grill and lighting the fire.
- Do not move the Grill while in use.
- Keep all bolts, nuts, and screws tight to be sure Grill is in safe working condition.
- Do not use Grill for indoor cooking or heating. Toxic carbon monoxide fumes may collect and cause death.
- Always use an oven mitt to protect hand when opening the grill lid and only do so slowly, to allow heat and steam to escape. Never lean over an open grill.

Grill Features

OPTIONS AVAILABLE:

- Canvas Carrying Bag
- Converter Hose To 20 lb. Tank

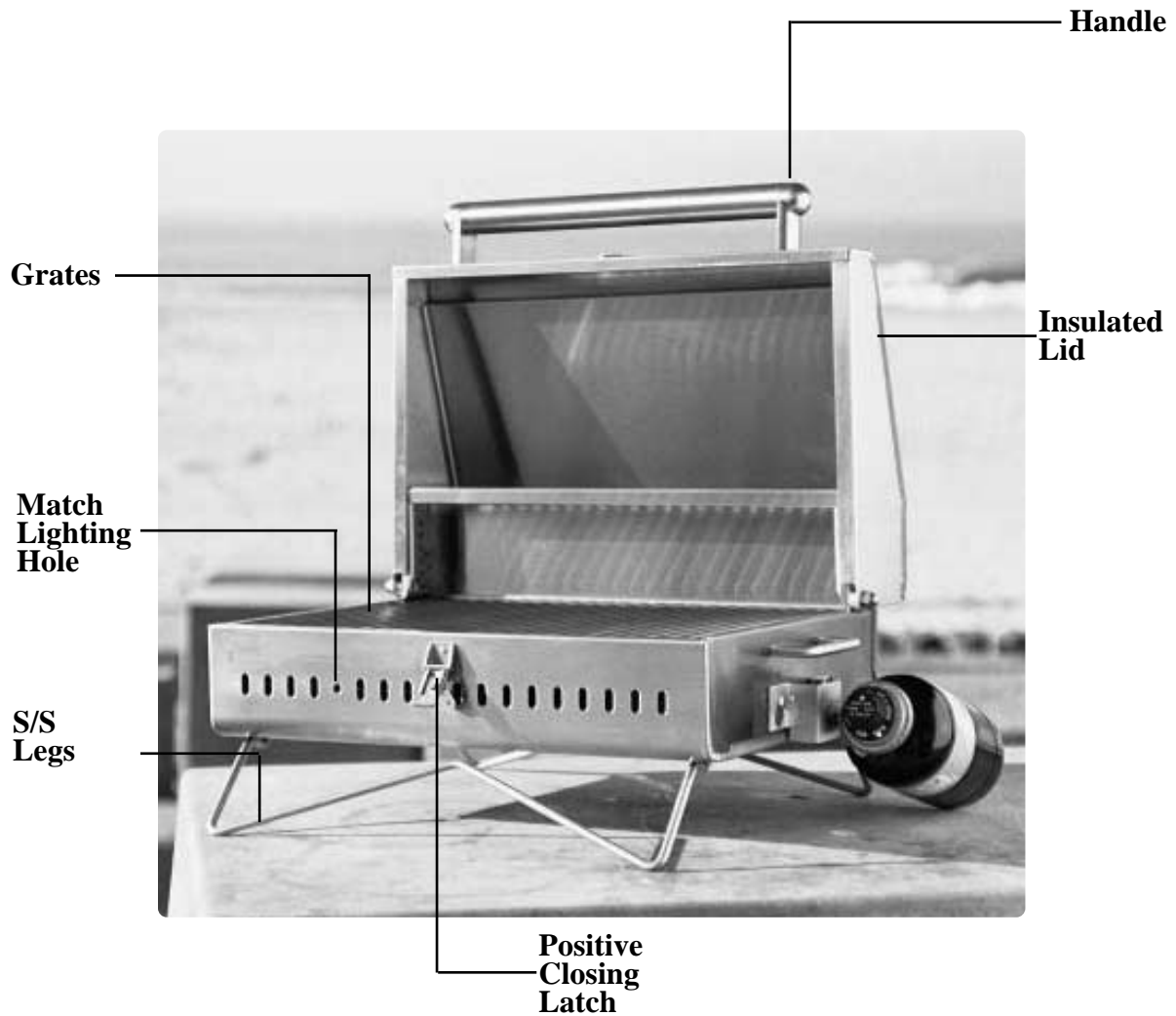

Specifications

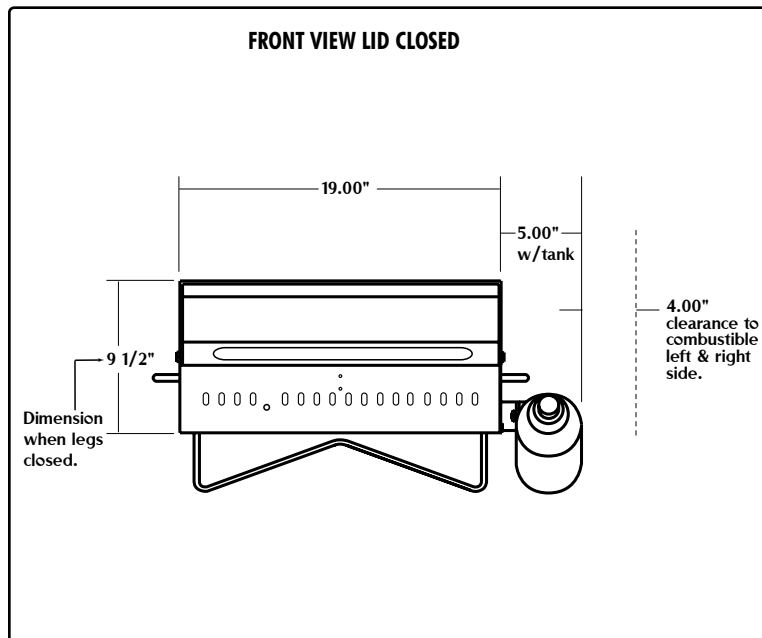
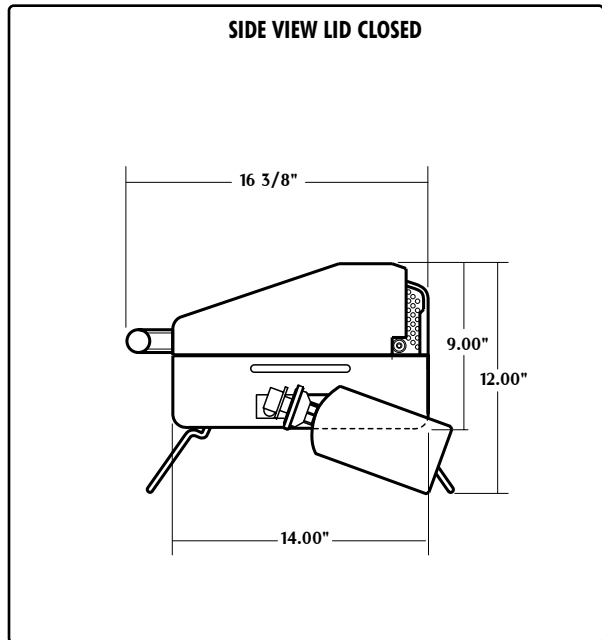
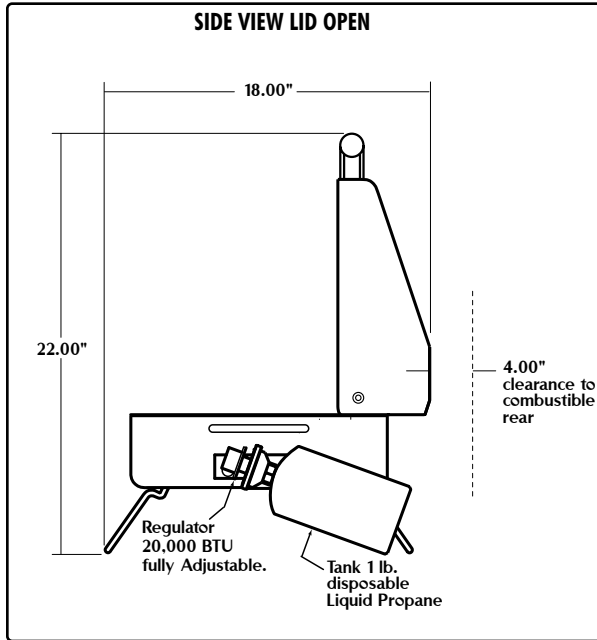

Using Your Grill



WARNING: *Keep small children away from open flames or while cooking to prevent injury.*

Gas Hook-Up

Unpack regulator assembly and install as shown. Make sure thumb screws are hand tight. Regulator should be able to rotate in bracket.

Note: *Screws are shipped attached to unit. Before use make sure that thumb screws are tighten to prevent injury.*

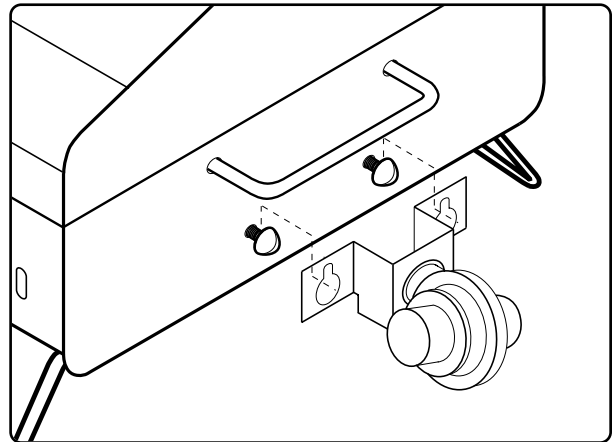

Lighting Instructions

To Light Burner: Light match and hold up to match light hole on front panel. Push and turn black knob on regulator to “Lighting Position” if burner does not light within 5 seconds turn gas off and wait for 30 seconds before repeating light process. Once lit turn knob to high, close lid and let warm up for 8-10 minutes.

NOTE: Before use *bottom of grill may be lined with aluminum foil for ease of cleaning.*

Tilt away Hood:

Leave the hood open for “Texas Style” open air grilling. Close the hood for “Smoker” cooking or whenever you want to hold in all the heat.

Care & Storage

Cleaning Stainless Steel:

To prevent burns or injury make sure grill is completely cool before cleaning. Clean the grill with caution. Avoid steam burns; do not use a wet sponge or cloth to clean the grill while it is hot. Some cleaners produce noxious fumes or can ignite if applied to a hot surface. The Tabletop grill is made from non-rusting and non-magnetic stainless steel. After initial usage, areas of the grill may discolor from the grills heat. This is normal.

There are many different stainless steel cleaners available. Always use the mildest cleaning procedure first, and always scrub in the direction of the grain. Soapy water should be sufficient for most cleaning.

Cooking grates:

Use solution of detergent and hot water just as you would for any cooking equipment. A stiff brush may be helpful in removing heavy deposits of grease and food.

Storage:

For your safety, before storing your Tabletop grill (*make sure unit is cool and embers are completely extinguished*).

Warranty:

Lifetime warranty on all stainless steel parts against defects in craftsmanship and workmanship.

Five (5) year warranty on regulator assembly.

Grill Recipes

Grilling Hints:

The cooking temperature of meat, whether rare medium, or well done, is affected to a large degree by the thickness of the cut. Expert chefs say it is impossible to cook a thin cut of meat rare. Cooking time is affected by the kind of meat, the size and shape of the cut, the temperature of the meat when cooking begins, and the degree of doneness desired.

Garlic Shrimp...

This recipe could serve as an appetizer or a main dish depending on the size of the shrimp. Thread shrimp on skewers so they will not fall through the grates, or grill them on aluminum foil. Adjust flame to a low position and cook for about 10 minutes.

12 oz. frozen peeled and deveined shrimp
1/2 C butter or margarine
4 cloves garlic, sliced

1 Tbl. chopped parsley
salt and pepper to taste
1/4 C fresh lemon juice

Cook garlic in butter for 2 to 3 minutes; add remaining ingredients except shrimp and heat until blended. Put shrimp in shallow dish; pour marinade over shrimp and let stand for 1 hour. Thread shrimp on metal skewers and cook for 5 minutes per side. Turn and baste occasionally. Makes 4 servings.

Island Steak...

Combine all ingredients except the steak (use garlic press to get celery juice). Marinate the steaks with this mixture for 30 minutes only. Drain the steaks and sear each side one minute with gas control in lowest position over moderate fire. Turn gas to medium position and cook to taste. Turn steaks twice.

6 Ribeye Steaks about 1" thick
1 C soy sauce
1 clove garlic crushed
1/4 C salad oil

Juice from small piece celery
(about 1/4 medium size stalk).

Grill Recipes

Smokey Mountain Spareribs...

Combine marinade ingredients and brush onto ribs. Use soaked wood chips and the indirect cooking method shown. Place meat bone side down on grates. Over moderate fire cook 1 1/2-2 hours with lid closed or until done. Turn and baste the ribs every 10 minutes during the last 30-40 minutes of cooking. 6 servings

1/2 C worcestershire sauce
1/2 C vinegar
2 racks spareribs (about 6 Lbs.)

1/2 C margarine, melted
1/4 Tsp. tabasco
1/2 Tsp. salt

Barbecued Pork...

Thicker pork cuts should be cooked on low. The secret is to brown the meat, but not to grill it so long that it becomes dry. Cook for about 20-30 minutes.

4 pork steaks or chops 1/2 thick
1 beef bouillon cube
1 Tsp. ground ginger
1/4 C molasses

1/4 C soy sauce
2 Tsp. salt
2 Tbsps. hot water

Dissolve bouillon cube in hot water, add remaining 4 ingredients and blend. Put meat in dish and pour marinade over meat, cover and refrigerate 2 hours turning occasionally. Remove pork from marinade, drain well and grill for 10-15 minutes per side, basting occasionally with remaining marinade. Makes 4 servings.

NOTES



As product improvement is an ongoing process, we reserve the right to change specifications or design without notice.

Litho in USA 1/2000 15080 Goldenwest Circle, Westminster, California 92683
Part No. 110026 (714) 903-1885 Fax (714) 9035805 www.outdoorconceptsinc.com

OUTDOOR CONCEPTS
PROFESSIONAL TABLETOP GRILL



OCI
OUTDOOR CONCEPTS, INC.