

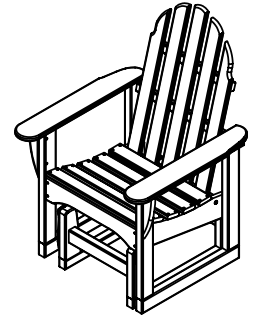

# Assembly Instructions

Model: ADSGL-1



## Step 1

Attach the seat to the sideframes using (6) 1½" bolts  
Do not tighten bolts yet

## Step 2

First Attach the back assembly *top* to the sideframes using  
(2) ¾" bolts  
Next attach the back assembly *bottom* to the seat using  
(2) 1½" bolts

## Step 3

Connect the glider frames to the braces  
using (4) 2¼" bolts

## Step 4

Attach the glider frame to the chair using  
(4) 1½" bolts  
Tighten all bolts at this time

- (2) Sideframes
- (1) Seat
- (1) Back
- (2) Brace
- (2) Glider frame
- (1) Hardware pack

### TOOLS NEEDED

Phillips head screwdriver or  
4mm hex key: Included

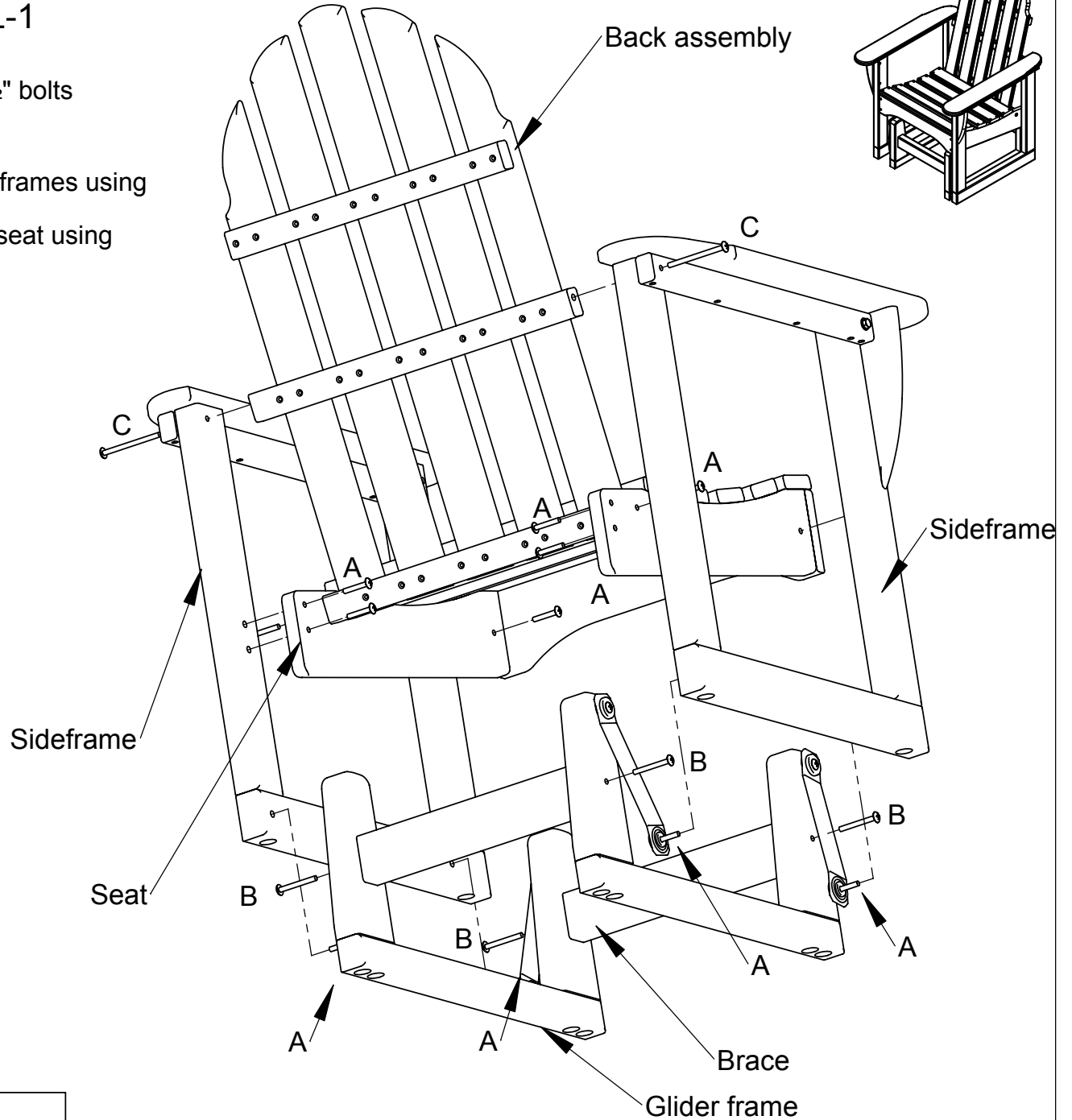

Qty.	Description
------	-------------

12	A - 1½" Bolt
4	B - 2¼" Bolt
2	C - ¾" Bolt

All bolts are 1/4-20

## Outdoor Leather Info

Outdoor Leather, used on the cushions of our Deep Seating Collections, is made of Marine Vinyl Fabric. The Outdoor Leather grade of Marine Vinyl is built to withstand moisture, hot sun and exposure to the elements. The best way to care and clean your outdoor leather is to spot clean with cloth and water. Approved cleaners are Vinyl Finish vinyl cleaner; dish soap such as Ivory or Dawn; Fantastik; or 303 Protectant. Cleaners not recommended are DC Plus, Formula 409, Murphy's Oil Soap, Simple Green, Armor All, Top Kote Sealant, Son-of-a-Gun, Orange 88, Roll-off, Turtle Wax/Tar Remover, Bleach/Baking Soda, APCO or Harbor Mate. Poly-Wood warranties outdoor leather for workmanship defects for 1 year from date of purchase.

## Cleaning/Maintenance

Poly-Wood furniture is made of HDPE plastic resin that has been purified and UV protected. It is generally cared for and cleaned with soap and warm water. For certain stains and additional cleaning power, a 1/3 bleach and 2/3 water solution can be used without affecting the color. Also, a popular method of cleaning is a high-pressure power wash. (Not to exceed 1,500 psi.) The surface characteristics of the product may require the use of a soft bristle brush to get into the creases.

The hardware used in the assembly and construction of our furniture is a 300 series commercial grade stainless steel that has an additional "Xylan" protective and cosmetic coating. Although the quality of the hardware has a high level of corrosive resistance, the hardware can show some sign of corrosion, especially in salt air environments. A practical solution to these signs of corrosion would be to wash the product with soap and warm water. Use a soft bristle brush to scrub the corroding areas of the hardware. Also, appliance touch up paint may be used in the appropriate color to protect the hardware. Appliance touch up paint can be purchased at local hardware stores.

## Warranty

Poly-Wood, Inc. warranties to the original purchaser for a period of five (5) years of residential use and one (1) year for commercial use starting from the date of purchase. This warranty covers any defects in the manufacturing and workmanship of the furniture components. "Defects" is defined as imperfections that impair the original function of the product.

Poly-Wood, Inc. shall not be liable for any failure, defect or damage resulting from or connected with the following:

- Assembly or handling of products after they leave our factory, including any lack of performance or improper performance in any way by the dealer or assembler
- Abnormal use of the products
- The application of paint, varnish or other coating or chemical not approved by Poly-Wood or the application of heat or radiation from an external source such as a barbecue grill, another appliance, fire or reflection from windows or doors
- Any lack of compatibility between our products and any other product not manufactured by us that causes damage to or failure of our products
- Labor, transportation or assembly costs
- Color or pattern variance between any new replacement section or pieces and other sections or pieces. (We reserve the right to discontinue or modify any product line or color without notifying the original purchaser. If the original product is not available, we retain the right to choose to provide replacement material of equal value or quality.)
- Fading, color change, or color match on any variegated profiles or accessories
- Damage caused by, among other things, weathering, oxidation, mold, mildew, use of incompatible accessories, fire, flood, lightning, ice, wind-borne objects, earthquake, hurricane, sun, cyclone, gale, tornado, weather of a catastrophic nature, acts of God, intentional acts, unreasonable use, misused, physical abuse, vandalism, riot, insurrection or civil disorder, accidents or corrosive atmospheres (such as those contaminated by acid rain, harmful chemicals or vapors)
- Color change due to weathering that is even and equal when exposed to the same or similar sunlight and other environmental conditions is excluded from the warranty because weathering will cause any colored surface to gradually lighten, darken, chalk or accumulate dirt or stains (the severity of these conditions depends on air quality, the geographic location of the property, and other local conditions over which Poly-Wood has no control)
- Assembly of hardware, accessory items or defects caused by their assembly

This warranty does not apply to normal wear and tear effects on the furniture, which are received by regular use of the furniture. Neither does it cover damage due to unauthorized repairs or alterations, negligence, misuse or abuse, improper assembly and acts of God. This warranty does not apply to the hardware used to assemble the furniture.

The original purchaser is responsible for providing proof of purchase and a written description of the defect. Possible solutions are replacement or repair of the defective furniture, replacement or repair of defective component, or authorization repairs by a third party.

Once the documentation has been received and evaluated, the customer will be notified of the solution. If the product is not returned within 60 days of date of purchase, the customer is responsible for all shipping charges that may apply.

**Poly-Wood Cushion Warranty:** Poly-Wood, Inc. warranties to the original purchaser for a period of thirty (30) days from date of purchase. This warranty does not apply to normal wear and tear effects on the cushions, which are received by regular use of the cushions. Neither does it cover damage due to unauthorized repairs or alterations, negligence, misuse or abuse, improper assembly and acts of God. This warranty covers any defects in the manufacturing and workmanship of the cushion.

Mail, Email, or fax the proper documentation.